

User manual

C4e - C6e Compact crane



Serial number:

Delivery date:

Reference: U.C6.03.00.EN

Version: 1.0

Translation of the original manual

TABLE OF CONTENTS

VERSION HISTORY	6
INTELLECTUAL PROPERTY RIGHTS	6
PREFACE	7
General terms & conditions	7
Warranty and liability	8
Target audience	8
Notes for the reader	8
1. INTRODUCTION	9
1.1 Intended use	9
1.2 EC Declaration	10
1.3 Technical data	11
1.3.1 Dimensions	11
1.3.2 Technical specifications	12
1.3.3 Sound pressure level	13
1.3.4 Hydraulic system	13
1.3.5 Electrical system	13
1.4 Type plate	13
2. DESCRIPTION AND OPERATION	15
2.1 Main components	15
2.2 Remote control	18
2.2.1 Remote control levers	19
2.2.2 Remote control buttons	21
2.2.3 Display on remote control	22
2.3 Electrical cabinet	23
2.4 Work lights	25
3. SAFETY	27
3.1 Introduction	27
3.2 Operating personnel	27
3.3 Warnings	27
3.3.1 Work environment	27
3.3.2 Use	28
3.3.3 Maintenance	32
3.4 Emergency stop	32
3.5 Stack lights	33
3.6 Load moment limiter (LML)	33
3.7 Pictograms	34
4. OPERATION	35
4.1 General precautions	35

4.1.1 Warnings	35
4.1.2 Assessing weather conditions	37
4.1.3 Inspecting lifting equipment	37
4.2 Daily inspection prior to use	38
4.3 Using the remote control	40
4.3.1 Changing and charging the remote control battery	40
4.3.2 Calibrating levers	41
4.4 Starting and switching off the crane	43
4.4.1 Starting the crane via 230 V connection	43
4.5 Moving the crane	44
4.5.1 Driving the crane	45
4.5.2 Crawler track width adjustment	46
4.6 Setting the outriggers	47
4.6.1 Display while setting the outriggers	48
4.6.2 Setting outriggers	49
4.6.3 Using nodding outriggers (optional)	53
4.7 Lifting	54
4.7.1 Display during lifting	54
4.7.2 Extending/retracting counterweight	55
4.7.3 Guiding the load	56
4.7.4 Lifting the load	57
4.8 Lifting with the winch	58
4.8.1 Adjustable section limits	60
4.8.2 Maximum angle of main boom and jib	61
4.8.3 Lifting without options	62
4.8.4 Lifting with jib	65
4.8.5 Lifting with adjustable section	67
4.8.6 Winch head positions in adjustable section – with main boom	68
4.8.7 Winch head positions in adjustable section – with jib	69
4.8.8 Attaching winch weight	70
4.8.9 Checking the winch stop	74
5. MAINTENANCE	75
5.1 Introduction	75
5.2 Warnings	75
5.3 Maintenance work	76
5.3.1 Weekly maintenance	76
5.3.2 Monthly maintenance	76
5.3.3 Scheduled service	76
5.3.4 First use	77
5.4 Maintenance schedule	78
5.5 Lubrication chart	79

5.6 Lubricate	80
5.6.1 Lubricants	80
5.7 Function mapping	81
5.8 Charging 80 V batteries	82
5.8.1 Battery level bargraph	82
5.8.2 Charging the batteries	84
5.9 Using emergency charging points	85
5.10 Maintaining the boom chains	87
5.11 Removing and installing jib	88
5.12 Removing and installing counterweight	91
5.12.1 Removing counterweight with your own equipment	92
5.12.2 Removing counterweight with external equipment	95
5.12.3 Fitting counterweight with your own equipment	96
6. TROUBLESHOOTING	99
6.1 Warnings pertaining to malfunctions	99
6.2 Troubleshooting	100
6.3 Fault codes	101
7. TRANSPORT, STORAGE AND DISPOSAL	103
7.1 Transport	103
7.1.1 Putting the crane in transport position	104
7.1.2 Securing crane for transport	106
7.1.3 Lifting crane for transport	107
7.2 Storing the crane	108
7.3 Waste disposal	109
8. ANNEXES	111
8.1 C4e load diagram	112
8.2 C6e load chart	113
8.3 Maximum outrigger pressure	114

VERSION HISTORY

Version	Date of issue	Remarks	From serial number
1.0	6 July 2022	First edition	2380 2691

Manufacturer

Hoeflon International B.V.
Zwolleweg 2
3771 NR Barneveld

T: +31(0)342 400 288

I: www.hoeflon.com

E: info@hoeflon.com

For technical support:

T: +31(0)342 219 050

E: service@hoeflon.com

INTELLECTUAL PROPERTY RIGHTS

All rights reserved

No part of this publication may be reproduced, stored in automated retrieval system, or made public in any form or by any means (electronically or mechanically, including photocopying, recording or otherwise) without the prior written permission of Hoeflon International B.V. This likewise applies to drawings and diagrams.

© Copyright 2022 Hoeflon International B.V.

PREFACE

This user manual applies to the C4e - C6e Compact crane. Throughout the rest of this document this type will simply be referred to as: Compact crane. This manual constitutes the operating instructions for the Compact crane.

Read this entire user manual carefully to familiarise yourself with the correct operation and maintenance of the Compact crane. The figures in this document are for illustration purposes only and may differ slightly from the Compact crane in your situation.

The machine is exclusively designed and intended for lifting loads as specified in this user manual. Any other use or application is contrary to the instructions. The use of the machine or parts thereof with a product that is not made or prescribed by Hoeflon International B.V. is done entirely at your own risk, and Hoeflon International B.V. makes no guarantees as to the suitability of such use, which is completely forbidden. This may lead to forfeiture of the right to service or warranty on the machine as described in this manual. Hoeflon International B.V. is never liable for such improper use.

All risk associated with failure to observe the instructions in this user manual and/or the provisions of the General Terms and Conditions is borne by the user and may result in bodily injury, damage to the machine and/or property damage. Hoeflon International B.V. recommends that the original copy of this user manual, including all the annexes, be kept in a safe, central place. It is also a good idea to keep a copy of this user manual near the machine at the workplace. For technical support, please contact the manufacturer (see details on the cover) or your dealer.

Hoeflon International B.V. is committed to keeping the information in this user manual complete, accurate and up to date. Hoeflon International B.V. accepts no liability for the consequences of errors, except in the case of wilful intent or deliberate recklessness on the part of Hoeflon International B.V. Hoeflon International B.V. cannot guarantee that changes made by unauthorised third parties to software and equipment, even if referred to in this user manual, will not affect the applicability of the information contained in this manual.

Although Hoeflon International B.V. has made every reasonable effort to ensure that this user manual is as accurate and helpful as possible, Hoeflon International B.V. does not provide any guarantees with regard to the accuracy or completeness of the information provided herein.

General terms & conditions

In all cases, Hoeflon International B.V. delivers the machine exclusively in accordance with the General Terms and Conditions applicable at the time of purchase. These General Terms and Conditions can be found on the website www.hoeflon.com.

This user manual supersedes all previous versions. No part of this user manual may be reproduced, or processed, modified, duplicated or distributed using electronic systems, in any form whatsoever, without prior written permission from Hoeflon International B.V.. We reserve the right to make technical and design modifications and all rights relating to the machine and this user manual.

The product as delivered may differ slightly from the product illustrations in this user manual.

Warranty and liability

The machine conforms to the applicable basic safety and health requirements of the EU directives and has been carefully tested for trouble-free operation at the factory. Should malfunctions nevertheless occur, please contact your dealer immediately.

Hoefflon International B.V. is not liable for any damage resulting from failure to observe the factory specifications in this user manual, non-adherence to the legal requirements or modifications to the equipment made by the user. Repairs you perform on the machine, modifications to the crane other than those described in the manual, improper use, lack of maintenance or unauthorised replacement of parts can have a considerable negative impact on the all aspects of safety and operation of the machine and will void the warranty.

No liability is accepted for damage or injury resulting from failure to use the machine in accordance with this user manual.

In connection with continuous further development and product improvement, we reserve the right to make changes to the technical design and execution at any time without prior notice. No liability is accepted for damage resulting from unintended use, and such use also voids the warranty.

Target audience

The machine may only be operated by personnel who have been sufficiently trained to work with the machine. Completion of the training at Hoefflon International B.V., concluded with a certificate, is mandatory. Those who fail to comply with the instructions and regulations in this user manual do so entirely at their own risk, and bodily injury and damage to the equipment may result.

Notes for the reader

The instructions, recommendations and warnings in this user manual are accompanied by the following terms and pictograms. Read these instructions carefully.

**DANGER**

Failure to understand and comply with these instructions may directly result in personal injury or damage to the machine.

**WARNING**

Failure to understand and comply with these instructions can lead to dangerous situations that may result in personal injury or damage to the machine.

**REMARK**

Note or tip with additional information for the user.

1.

INTRODUCTION

1.1 Intended use



Figuur 1.1 C6e Compact Crane

The C4e - C6e Compact crane is suitable for lifting loads such as building materials and glass walls in a limited space. Due to its compact dimensions, the crane can be transported on a trailer. The cranes are powered by a battery and controlled via a radio remote control.

The crane is designed so that charging and working can be done at the same time by connecting the crane to the mains at the workplace.

It is only permitted to use the crane for the intended uses, which are described in this manual.

Additionally, you are not permitted to change movement speeds yourself. Also it is absolutely prohibited to exceed the maximum working load, and it is forbidden to bypass sensors.

This manual has been prepared with the greatest possible care and made as complete as possible. Continuous safety vigilance in both familiar and unfamiliar situations is, however, always necessary.

1.2 EC Declaration

Hoeflon International B.V. declares that the crane is in conformance with applicable European Directives. The EC Declaration of Conformity is attached as an annex.

1.3 Technical data

1.3.1 Dimensions

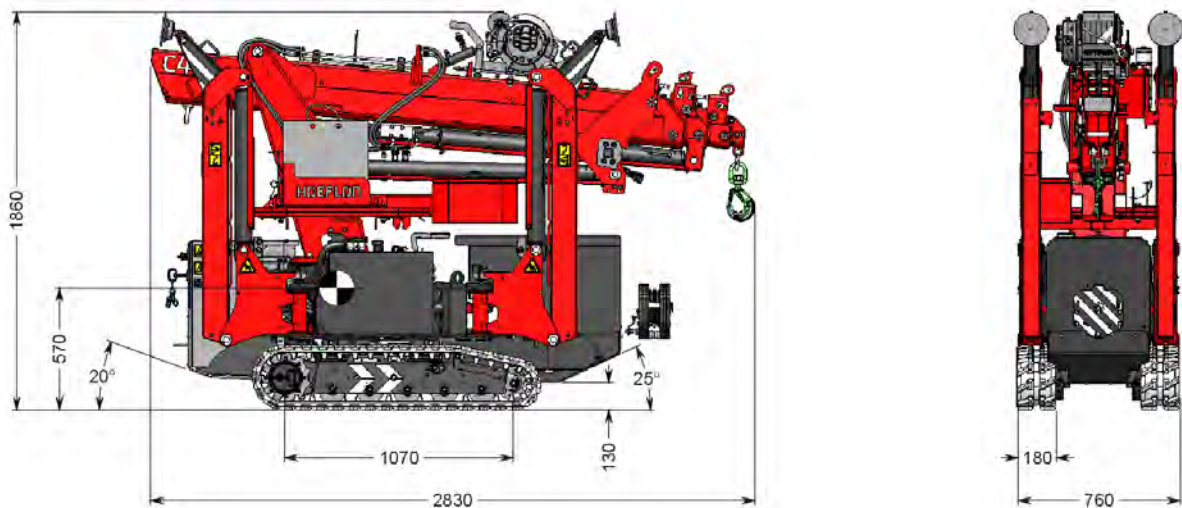

Figur 1.2 Front and side views C4e with centre of gravity indication

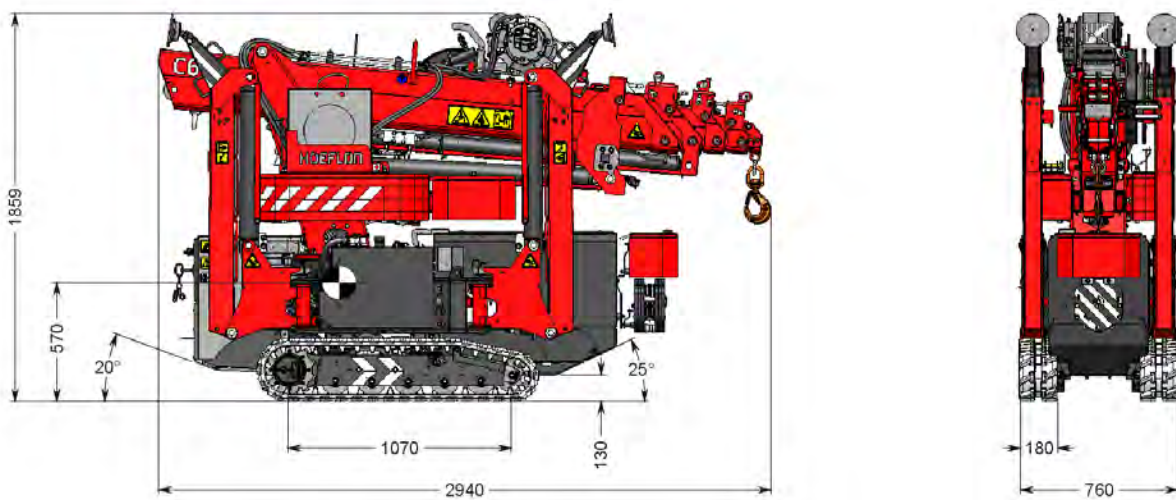

Figur 1.3 Front and side views C6e with centre of gravity indication

1.3.2 Technical specifications

General data	
Machine brand	Hoeflon
Maximum slope angle	15°
Clearance angle	20°
Maximum lean angle with outriggers extended	5°
Ground clearance	130 mm
Ambient temperature	-10 to 40 °C
Slewing range	360° (infinite rotation)
Max. working load and lifting point of crane	See load chart provided in the annexes
Maximum wind speed	10.8 m/s (6 Beaufort)

Technical data	C4e	C6e
Transport length (without jib)	2613 mm	2729 mm
Transport width	760 mm	760 mm
Transport height	1856 mm	1855 mm
Maximum outer dimensions with outriggers extended at 45°	4440 x 4220 mm	4440 x 4220 mm
Total weight with counterweight and jib	1950 kg	2906 kg
Total weight, jib	150 kg	150 kg
Total weight, jib tube	18 kg	18 kg
Total weight, counterweight 1) with outriggers hydraulically extended 2) with outriggers manually extended	114 kg	520 kg ¹ 575 kg ²
Weight of winch weight with hook	33 kg	33 kg
Weight of winch head	13 kg	13 kg
Maximum ground pressure per surface area	11 kg/cm ²	15 kg/cm ²
Maximum outrigger pressure per outrigger	2450 kg	3300 kg
Maximum load, jib horizontal and retracted	700 kg	900 kg
Maximum load, jib horizontal and extended	510 kg	514 kg
Maximum load, winch	1000 kg	1000 kg
Maximum load with reeving	1 x reeving 2000 kg	1 x reeving 2000 kg 2 x reeving 3000 kg
Pulling force (weight the crane can pull)	400 kg	500 kg
Centre of gravity	Under the lifting hook from the top end of the boom and 570 mm from underside of crawler track.	

1.3.3 Sound pressure level

The noise measurements were conducted on a flat surface.

Noise level dB(A)	At 1 metre
Front, motor side	63 dB
Rear, control side	65 dB

1.3.4 Hydraulic system

Hydraulic system	
Volume of hydraulic tank	16 litres
Pump type	Gear pump
Maximum pump pressure	250 bar

1.3.5 Electrical system

Electrical system	
Electric motor	80 VDC 9.5 kW
Drive (battery pack)	Voltage: 80 V Capacity: 163 Ah Type LiFePO4
System voltage (battery)	24 V (2x 12 V, 18 Ah)
Charging	Charging voltage: 230 V AC Maximum charging capacity: 2.3 kW

1.4 Type plate

A type plate containing the machine data is mounted on the machine. This type plate may not be removed. The CE mark indicates that the machine conforms to the applicable standards for the European Economic Area.



Type	The type of machine
Model	The brand of the machine
Serial no.	The serial number of the machine
Year	The year the machine was built
Weight	The weight of the machine
Max. capacity	Maximum working load



REMARK

Please provide the type number and serial number when ordering parts.

2.

DESCRIPTION AND OPERATION

2.1 Main components

The crane is exclusively intended for lifting and raising loose objects by means of a hook. The objects to be transported must fall within the specifications stated in this user manual.

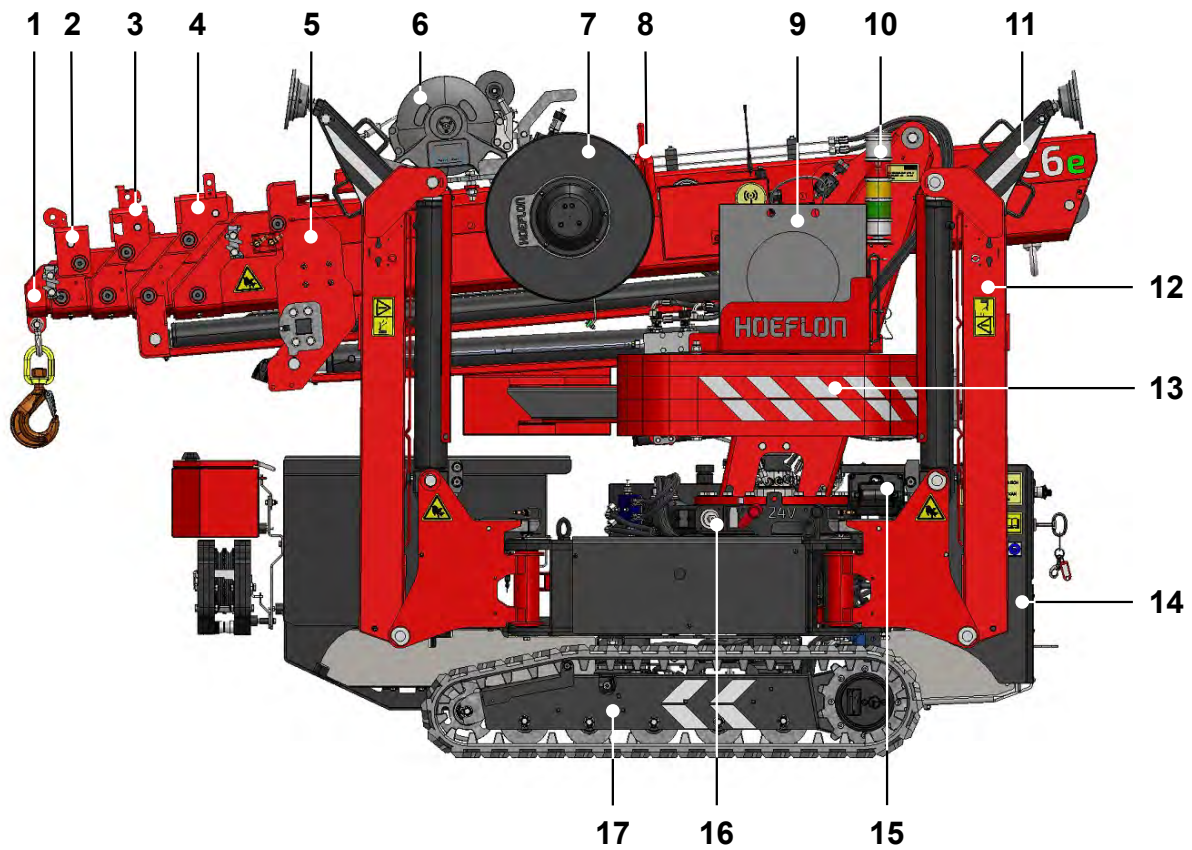

Figuur 2.1 Left view C6e

- | | | | |
|---|-------------------------|----|------------------------------------|
| 1 | Boom section 5 | 10 | Stack light |
| 2 | Boom section 4 | 11 | Extension leg |
| 3 | Boom section 3 | 12 | Outrigger foot |
| 4 | Boom section 2 | 13 | Counterweight |
| 5 | Boom section 1 | 14 | Electrical cabinet |
| 6 | Lifting winch | 15 | Battery charger for remote control |
| 7 | Hydraulic/electric reel | 16 | Charging connector 230 V |
| 8 | Lifting point | 17 | Track undercarriage |
| 9 | Outrigger pads | | |

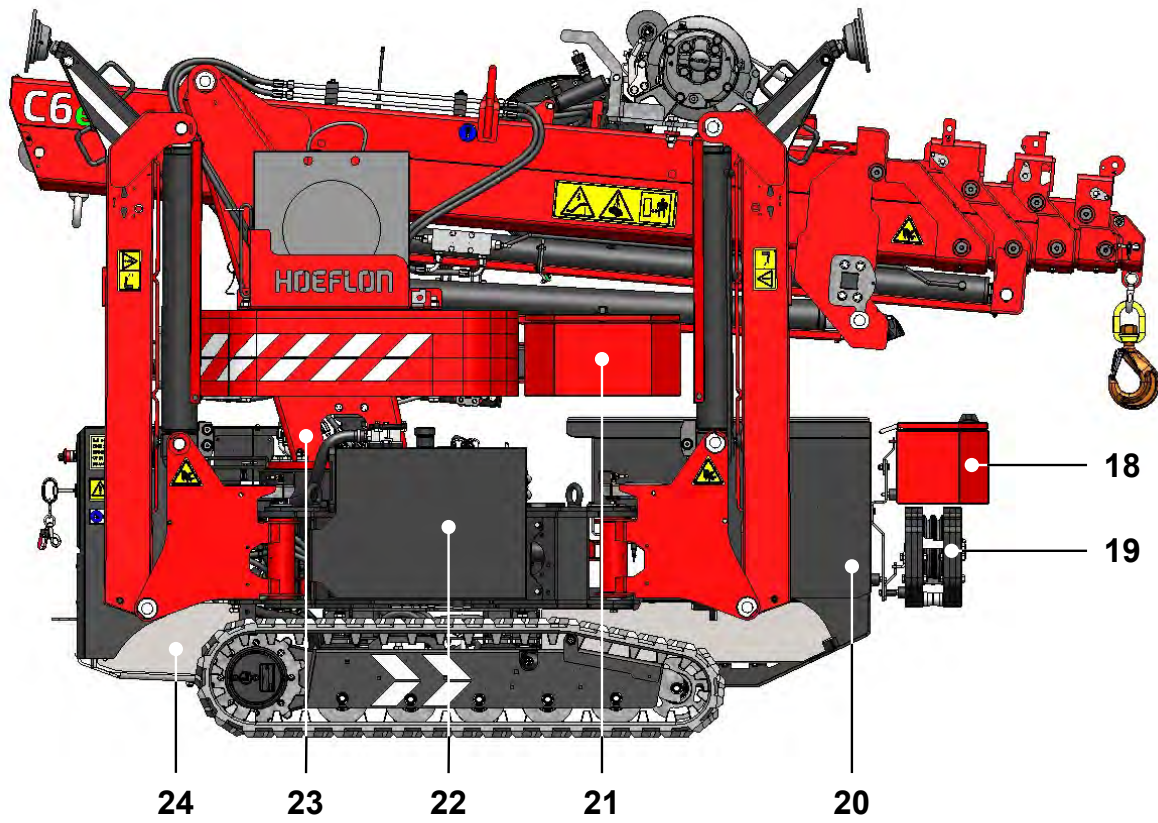

Figuur 2.2 Right view C6e

- | | | | |
|----|-------------------|----|--------------------|
| 18 | Toolbox | 22 | Hydraulic oil tank |
| 19 | Winch weight | 23 | Crane column |
| 20 | 80 V battery pack | 24 | 2 x 12 V battery |
| 21 | Toolbox | | |

2.2 Remote control

The crane is operated with the remote control. This section explains the buttons and functions of the remote control.

- The remote control is sealed against splashed water and rain.
- Never clean the remote control and receiver with high pressure and do not immerse them.
- Keep the remote control clean; make sure that pictograms, screen and labels remain legible.
- Wear the remote control using the hip belt or neck belt.
- Always have a second battery in the charger.
- Switch off the remote control if it is not in range or makes poor contact. Then switch the remote control on again, and it will search for another channel.



Figuur 2.3 Remote control

2.2.1 Remote control levers

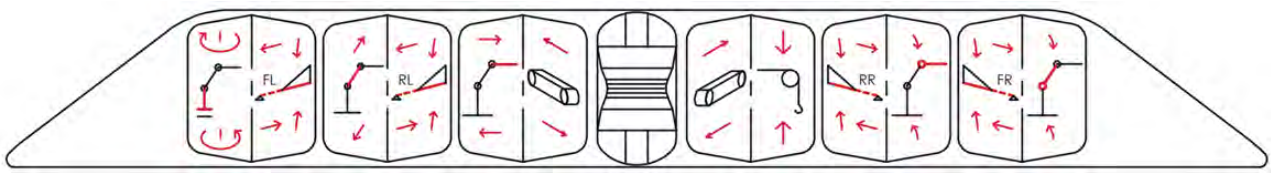



The standard functions with the main switch on the electrical cabinet in position 1 are as follows:

















No.	Image	Function	Lever backwards	Lever forwards
1		Operate outrigger (LF – left front)	Up	Down
2		Operate outrigger (LR – left rear)	Up	Down
3		Operate crawler track (L – left)	Backwards	Forwards
4		Operate crawler track (R – right)	Backwards	Forwards
5		Operate outrigger (RR – right rear)	Up	Down
6		Operate outrigger (RF – right front)	Up	Down
7		Display (see section <i>Display on remote control</i>)		

The standard functions with the main switch on the electrical cabinet in position 2 are as follows:

No.	Image	Function	Lever backwards	Lever forwards
1		Slew main boom	Left	Right
2		Extend/retract main boom	Retract	Extend
3		Extend/retract jib	Retract	Extend

No.	Image	Function	Lever backwards	Lever forwards
4		Raise and lower winch	Raise	Lower
5		Jib up and down	Jib up	Jib down
6		Boom up and down	Boom up	Boom down
7		Display (see section <i>Display on remote control</i>)		

2.2.2 Remote control buttons

Button	Function	Explanation
	Emergency stop	The crane receives a signal to stop all communication. Pressing it stops all crane functions.
	On/off	Switch remote control on and off.
	Link remote control and crane / sound horn	Pressing once: activate connection between remote control and crane. Pressing again after the connection is active: sound horn.
	Release left-side outriggers	Release left-side outriggers for swinging. Extend and retract in combination with lever 1 (front outrigger) 2 (rear outrigger).
	Temporarily increase LML	See explanation below this table.
	Switch between undercarriage and upper part	Green light on: upper part (lifting) Green light off: Undercarriage (setting outriggers and driving) Button only works if no lever or button has been operated for at least two seconds. After pressing the button, the crane's mode of operation changes and the information on the display changes.
	Navigation panel	
	 Confirm	 Down arrow
	 Up arrow	 Left arrow
	 Right arrow	 Back
	Extend crawler tracks/counterweight	Extend crawler tracks in undercarriage mode.
		Extend counterweight in upper part mode.
	Retract crawler tracks/counterweight	Retract crawler tracks in undercarriage mode.
		Retract counterweight in upper part mode.
	Work light	Switch work lights on and off.
	Release right-side outriggers	Release right-side outriggers for swinging. Extend and retract in combination with lever 5 (rear outrigger) 6 (front outrigger).

Buttons that are not explained are not used on this crane.

110% button

This button may only be used if the crane is in an unsafe situation. By pressing this button, the crane can be brought back to a safe situation. As long as the button is pressed, the LML is increased to 110%. Never use this button to increase the crane's outreach or to continue winching.

2.2.3 Display on remote control



Figuur 2.4 Example of display on remote control

2.3 Electrical cabinet



DANGER

Remove key from key switch when performing work on the electrical system and prevent unauthorised people from switching on the crane

There are a number of functions present on the electrical cabinet. In *Figuur 2.5* the functions on the exterior are shown, with explanations below. In *Figuur 2.6* the functions inside the cabinet are shown, with explanations below.



Figuur 2.5 Electrical cabinet exterior

Button	Description	Function
	Main switch, implemented as key switch	0: Crane switched off 1: Undercarriage (driving crane or setting outriggers) 2: Upper part (lifting with crane)
	Emergency stop button	Switches drive off
	Power on indicator	Lit when the main switch is on
	Mains power indicator	Lit when the crane is connected to the mains

See section *Pictograms* for explanation of the stickers.

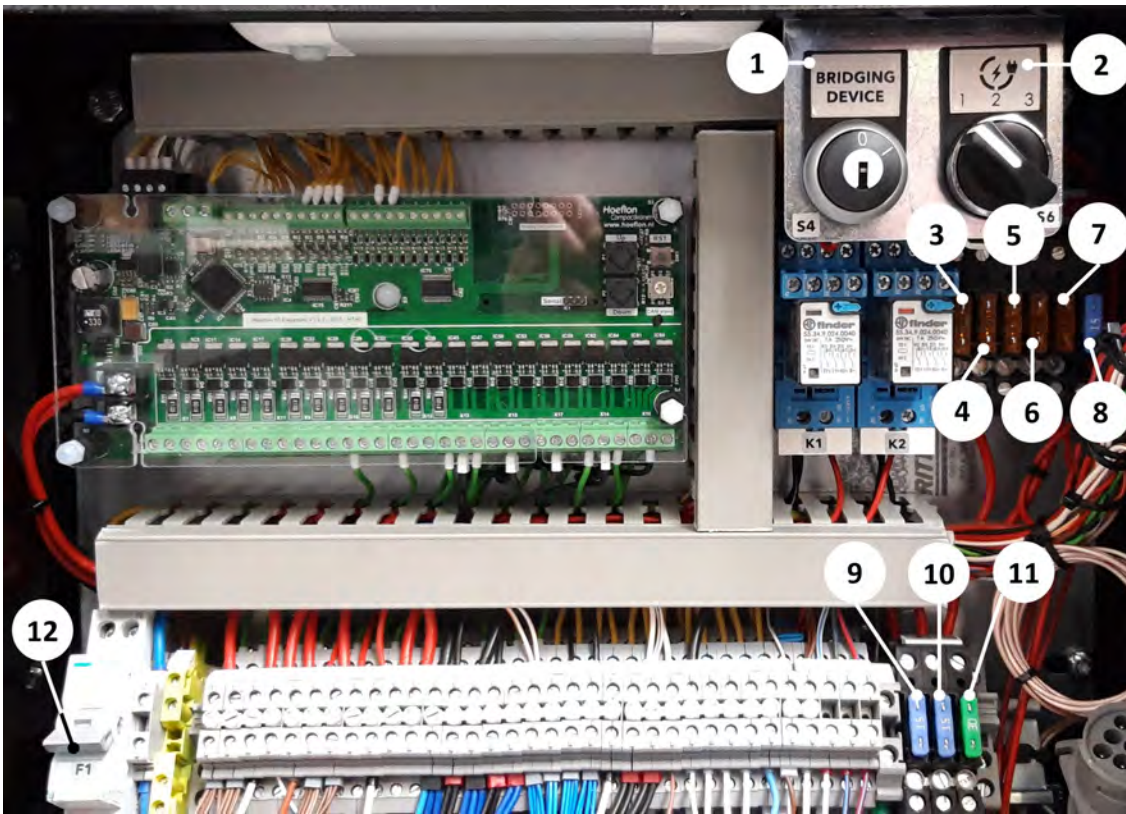

Figuur 2.6 Electrical cabinet interior

Code	No.	Description	Function
	1	Key switch	0: neutral 1: complete override of safety functions
	2	Maximum charging current switch	Switch for setting the maximum charging current to avoid overloading the 230 V circuit. The switch has the following positions: 1: charging with 2.5 A from the mains (230 V) 2: charging with 5 A from the mains (230 V) 3: charging with 10 A from the mains (230 V)
F1	12	Circuit breaker 230 V 16 A	
F2	9	Blade-type fuse 15 A (blue)	Circuit board 1, controller, upper part
F3	10	Blade-type fuse 15 A (blue)	Circuit board 1, battery charger and sensors
F4	11	Blade-type fuse 30 A (green)	Constant power
F5	3	Blade-type fuse 5 A (red)	Gateway
F6	4	Blade-type fuse 5 A (red)	Battery pack 1
F7	5	Blade-type fuse 5 A (red)	Maximum charging current switch
F8	6	Blade-type fuse 5 A (red)	Cooling fan (option)
F9	7	Blade-type fuse 5 A (red)	CAN power supply
F10	8	Blade-type fuse 15 A (blue)	Valve block

2.4 Work lights



The work lights on the crane can be operated as follows:

- Switch on by pressing the **Work light** button on the remote control.
- Switch off by pressing the **Work light** button again.

3.

SAFETY

3.1 Introduction

This chapter contains the general safety precautions to be observed during use of the crane. It is of paramount importance that the user closely observes these warnings and precautions to prevent injury to themselves and others and damage to the equipment.

Make sure you are familiar with all applicable legal requirements before you start operation, in particular the requirements for occupational safety and accident prevention.

Always be aware of the weight of components. Always use the correct tools and approved lifting equipment.

3.2 Operating personnel

Operating personnel may not be under the influence of narcotics or alcohol and must be at least 18 years of age. These people must be familiar with all the functions and tools associated with this crane. People who work with the crane must wear safety shoes, gloves and a safety helmet.

In the Netherlands, the operating personnel must be in possession of a valid mobile crane operator's licence, TCVT W4-01.

3.3 Warnings

Every employee must heed the following warnings and regulations.

3.3.1 Work environment

**REMARK**

Keep the crane clean and prevent dirt from accumulating.

**REMARK**

Use communication equipment if the operator does not have an overview of the entire operating radius.

3.3.2 Use

**DANGER**

Lifting with the boom below horizontal is prohibited, due to the extension and retraction chains. Lifting with the jib below the horizontal line is allowed.

**DANGER**

Never enter the operating radius; this can have serious consequences.

**DANGER**

Do not let unauthorised people enter the crane's operating radius during operation.

**DANGER**

Never move a load over people.

**DANGER**

It is prohibited to use the crane with a damaged or weakened hook, cable or other lifting equipment.

**DANGER**

Avoid contact with rotating and moving parts.

**DANGER**

It is prohibited to use the crane in the vicinity of high voltage cables.

**DANGER**

Never climb on the crane when it is in motion or when it is being used.

**DANGER**

It is prohibited to use the crane in an explosive environment.

**DANGER**

Never transport the crane if the crane, outriggers and counterweight are not completely collapsed, stowed, retracted and locked. Also, the crane must not be loaded. This can lead to dangerous situations and damage the crane!

**DANGER**

Make sure the load bearing capacity of the ground is adequate, and use access mats or outrigger pads. Never place the crane on manholes or beside/in holes.

**DANGER**

Outriggers may only be used on a suitable surface.

**DANGER**

It is prohibited to use the crane to transport or lift people.

**DANGER**

It is prohibited to use the crane to drag loads, pull loads free (such as pulling out poles), cause loads to fall, push loads or winch loads at an angle. This can lead to dangerous situations and cause damage to the crane.

**DANGER**

Never lift heavier loads than the maximum permitted workload according to the load chart.

**DANGER**

Never leave the crane unattended with a load hanging from the crane.

**DANGER**

Only move loads that can move freely from the surface they are sitting on and that are located directly beneath the hook!

**DANGER**

Remove key from key switch when performing work on the electrical system and prevent unauthorised people from switching on the crane

**DANGER**

Never use the 110% button to increase the crane's outreach or to continue lifting.

**DANGER**

Never place materials or tools on the motor shroud of the machine or on the crane. These objects may end up in the motor compartment and cause a short circuit there.

**DANGER**

It is prohibited to use the crane during lightning storms and/or wind speeds of Beaufort Force 6 or higher.

**DANGER**

HIGH VOLTAGE! (Danger of electrocution). Removing and opening the HV box is prohibited. Only technicians trained by Hoeflon are allowed to disconnect cables.

**DANGER**

Do not open or disassemble the batteries or charger.

**DANGER**

Disconnect the battery when replacing electrical components.

**WARNING**

Only suitable, trained people who are familiar with the content of this user manual and have completed the user training provided by Hoeflon International B.V. may operate or work with the crane!

**WARNING**

Dangerous situations can arise in which there is intense interaction between the crane, operator, load, surroundings and ground. Thorough knowledge and preparation is a must.

**WARNING**

When the crane is connected to the mains, it is prohibited to use the crane in rain, snow, or high or wet grass or to drive through water.

**WARNING**

It is prohibited to use the crane on public roads; the crane does not have the necessary markings and lighting.

**WARNING**

Hot parts of the motor and components of the hydraulic system can cause burn injuries.

**WARNING**

Make sure the outriggers are not extended too far, to prevent contact between the counterweight and outriggers during slewing.

**WARNING**

ATTENTION: During booming up, the maximum angle per attachment is limited. If this angle is exceeded, the cable may scrape along the boom or fly jib, for example. Please refer to the user manual for information on limits.

**WARNING**

Avoid contact with the outriggers when setting or retracting the outriggers (crushing danger).

**WARNING**

Never transport a loaded crane.

**WARNING**

Always collapse the crane after use in the open air if the crane is to be left outside (due to wind).

**WARNING**

Mind the height restriction in covered areas.

**WARNING**

When working in poorly lit areas, artificial light must be used to carry out the operations safely.

**WARNING**

Make sure that no loose objects are present on the load or boom during lifting operations.

**WARNING**

The boom is flexible and bends when lifting the load. Be aware that the boom will spring back when the load is put down.

**WARNING**

The lifting point on top of the jib is only intended for lifting the detached jib. It is forbidden to use this lifting point for lifting a load or for securing the crane.

**WARNING**

Take extra caution and safety measures in situations where the ground, surroundings or load strongly influences or restricts the use of the crane. When in doubt about the safe use of the crane, request advice from a specialist or contact your dealer or the manufacturer.

**WARNING**

Maintain a close watch on the active outrigger during extension to prevent foot entrapment.

**WARNING**

The crane may only be moved by means of hold-to-run control. Levers must be actively continuously in order to drive. Always maintain a good view of the surrounding area, to avoid hitting people or objects.

**WARNING**

Make sure the crane and track undercarriage are parallel to one another before collapsing the crane!

**WARNING**

Use a suitable connection to the mains supply. An unsuitable mains connection may trip the overcurrent protection.

**WARNING**

Never use the emergency stop button to switch off the crane during normal operation.

**REMARK**

Follow national regulations concerning working conditions and work safety when using the crane.

**REMARK**

When driving the crane on soft or sloping ground, keep the outriggers 10 cm above the ground to mitigate the risk of tipping over.

**REMARK**

Never leave a crane unattended with the keys and remote control.

**REMARK**

If the outriggers are parallel to the crane on the counterweight side, booming up will stop

automatically at 60°.

**REMARK**

Charge the batteries at the end of each day to keep them balanced and in good condition. Condition: The emergency stop buttons must not be pressed, and the main switch on the electrical cabinet must be in position 0.

**REMARK**

After operating the emergency stop button, the crane must be reactivated. To do so, turn the main switch on the electrical cabinet to position 0 and then to position 1.

3.3.3 Maintenance

**DANGER**

It is prohibited to bypass a sensor; doing so can cause danger to life and damage to the crane. If a sensor fails, contact Hoeflon Service immediately.

**WARNING**

Before disconnecting hydraulic lines and hoses, precautionary measures must be taken to ensure that the line/hose is no longer under pressure once the supply of energy to the system has been switched off. This can be achieved by moving the control levers back and forth.

3.4 Emergency stop

There is an emergency stop button on the back of the crane and on the remote control. These emergency stop buttons have the same function: when pressed, all crane functions are stopped.

Only operate the emergency stop button in the event of an emergency or disaster.

**WARNING**







Never use the emergency stop button to switch off the crane during normal operation.

**REMARK**

After operating the emergency stop button, the crane must be reactivated. To do so, turn the main switch on the electrical cabinet to position 0 and then to position 1.

3.5 Stack lights

A stack light is fitted on the crane. The meaning of the colours is shown below. When bypassed by means of the key switch, the stack light produces an audible signal to alert everyone in the vicinity.

Light	Sound	Explanation
		Crane controls active
		Driving
		90% to 100% load
		100% load
		Override 100% to 110%
		Override without protection



Figuur 3.1 Stack lights

3.6 Load moment limiter (LML)

The following describes how the crane is protected against overload by the LML (Load Moment Limiter).

When the crane is raised on the outriggers and the ignition switch is set back to position 2 (crane operation) the crane knows exactly how it is standing on the outriggers. Based on this, the crane knows what it can lift where.













When a load is hanging from the crane and the crane's outreach is increased, if the crane enters the range in which it is no longer allowed to lift the load, it will automatically stop increasing the outreach. The red lamp in the stack light will also light and an acoustic signal will sound.

Now the crane can only be operated in the direction in which the load comes back into the safe range. That is, the direction in which the outreach is reduced. Winding out winch cable, jibbing down and retracting the jib are allowed.

The following functions can be blocked by the LML: Extending boom and jib, winding in the winch cable, booming and jibbing up, slewing the upper part, retracting the counterweight.

3.7 Pictograms

The pictograms used are shown below. These may not be removed. Missing or damaged pictograms must be replaced immediately!

Pictogram	Meaning	Location
	Use of safety shoes, gloves and safety helmet is mandatory	On the right side of the electrical cabinet
	Lifting point for lifting the crane.	On the boom
	Charge indicator for 80 V batteries	On the chassis in front of the turntable
	From left to right: Do not use in the vicinity of high-voltage cables, suspended loads and maintain sufficient distance	On the main mast and on jib section 1
	Risk of entrapment when operating the counterweight and maintain sufficient distance	On the right side of the electrical cabinet
	Read the manual before operating the crane	On the right side of the electrical cabinet
	Label that shows when annual inspection is due (Netherlands only)	On the door of the electrical cabinet
	Position of the main switch: 0 = off 1 = undercarriage (outrigger operation) 2 = upper part (crane operation)	On the door of the electrical cabinet
	Risk of entrapment when setting the outriggers	On the outriggers
	Risk of crushing or cutting	On the crane at pivot points and on the outriggers at the cylinders
	Electrical danger	On the door of the electrical cabinet
	Risk of hand entrapment	On the counterweight
	Warning for radio remote control	Near receiver on upper part electrical cabinet

4.

OPERATION

4.1 General precautions

4.1.1 Warnings

Every employee must observe the following warnings and regulations while working with the crane.

**DANGER**

Never enter the operating radius; this can have serious consequences.

**DANGER**

Do not let unauthorised people enter the crane's operating radius during operation.

**DANGER**

Never move a load over people.

**DANGER**

It is prohibited to use the crane in an explosive environment.

**DANGER**

Make sure the load bearing capacity of the ground is adequate, and use access mats or outrigger pads. Never place the crane on manholes or beside/in holes.

**DANGER**

Outriggers may only be used on a suitable surface.

**DANGER**

Never use the 110% button to increase the crane's outreach or to continue lifting.

**WARNING**

Always operate the crane with extreme care. Avoid abrupt movements and maintain contact with any signal men.

**WARNING**

The bypass in the electrical cabinet bypasses sensors. It is prohibited to bypass the winch sensor. Use of the bypass is entirely at your own risk.

**WARNING**

Always perform the daily inspection first!

**WARNING**

Always check for unsafe situations!

**WARNING**

Make sure that the crane's operating radius is cleared and fenced off so that unauthorised personnel cannot enter the area.

**WARNING**

To charge the crane, use a cable with a minimum conductor cross-sectional area of 2.5 mm² and a maximum length of 25 m.

**WARNING**

At the end of each day that the crane is used, plug the charging cable into the mains socket so that the battery packs are charged and balanced. This keeps the battery packs in good condition.

**WARNING**

Do not use the crane until precautions have been considered and taken to safeguard the user, machine, load, surroundings and ground.

**WARNING**

Switch off the control while performing other work to prevent unintentional movements.

**WARNING**

Never leave the crane unattended, unless the key has been removed.

**WARNING**

Make sure that no loose objects are present on the load or boom during lifting operations.

**REMARK**

The directions of movement on the remote control best match those of the crane when you are standing behind the crane.

**REMARK**

Use the toolbox (if present) only for crane parts and the tools necessary for working with the crane.

4.1.2 Assessing weather conditions

The weather can affect the use of the crane and disrupt the work schedule. Therefore, observe the following warnings and remarks.

**DANGER**

It is prohibited to use the crane during lightning storms and/or wind speeds of Beaufort Force 6 or higher.

**WARNING**

Check the weather forecast. This is important for scheduling the work.

**WARNING**

If lightning has struck the crane, a new certification inspection is required.

4.1.3 Inspecting lifting equipment

It is important that the lifting equipment is in order. Therefore, observe the following warnings and remarks.

**DANGER**

It is prohibited to use the crane with a damaged or weakened hook, cable or other lifting equipment.

**DANGER**

The user is responsible for safe operation of the crane, the selection of appropriate accessories (based on intended use, capacity, validity of inspection stickers and visual inspection) and the personal safety of the operator and people in the vicinity.

**DANGER**

It is forbidden to lift without counterweight on the crane. The crane can tip over.

4.2 Daily inspection prior to use



DANGER

HIGH VOLTAGE! (Danger of electrocution). Removing and opening the HV box is prohibited. Only technicians trained by Hoeflon are allowed to disconnect cables.

For your own safety and to obtain the maximum service life from your equipment, it is of great importance that you always inspect the condition of the crane before use. Resolve any problems you find, or have your dealer do so, before you use the crane again.

Perform the daily inspection as follows:

1. Before performing the daily inspection, first make sure that the crane is horizontal (to ensure oil level indication is correct).
2. Check that the emergency stop button stop on the remote control is pressed.
3. Perform a thorough general visual inspection of the crane. Look, in particular, for oil leakage, leaking cylinders, loose connections, dirt accumulation and any damage. Remove any dirt which has accumulated, and have necessary repairs performed if you observe a leak.
4. Check the oil level in the hydraulic tank (see *Figuur 4.1*). If necessary, top up the tank with Hydro 46.
5. Check that all protective caps and covers are in position and that all nuts and bolts are in place and secured firmly.
6. Make sure that the pins are present and secure. For example, at the outrigger, jib and lifting equipment.
7. Visually check the tension and condition of the crawler tracks. If defects are found, contact the dealer.
8. Tension the crawler tracks by fitting the grease gun to the grease nipple in the middle of the track beams and pumping to 60 bar (see *Figuur 4.2*). The crane should preferably be positioned so the crawler tracks do not touch the ground. The crawler tracks must not be too tight.
9. Check if the lights on the sensors for the boom and jib pulse on/off during extension. This is how the length of the boom is measured.
10. Check that the crane control levers return to the centre position automatically and that the manual outrigger controls are automatically locked.
11. Make sure that all loose parts are correctly stored and/or secured.
12. Check for correct operation of the emergency stop button; never lift if the emergency stop button is not functioning properly. If defective, always have it repaired immediately.
13. Check all rotating and moving parts for wear and damage.
14. Check the chains for wear and damage.
15. Check for wear of the lifting cable, hook and other lifting accessories.



Figuur 4.1 Checking oil level

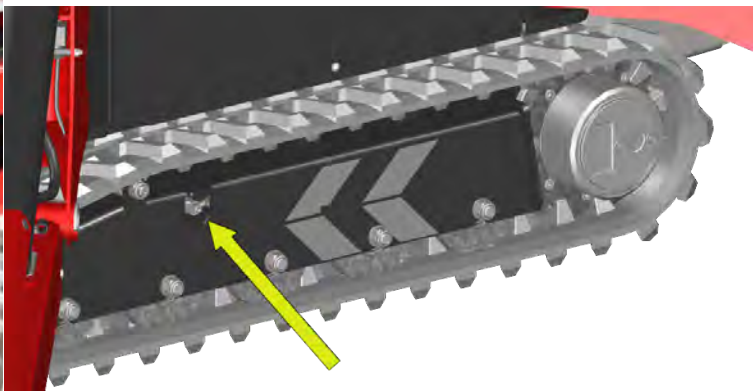

Figuur 4.2 Tensioning crawler tracks

4.3 Using the remote control

4.3.1 Changing and charging the remote control battery

To change the battery of the remote control:

1. Push in the two buttons next to the battery.
2. Remove the discharged battery from the remote control.
3. Take the charged battery from the battery charger and place it in the remote control.
4. Place the discharged battery in the battery charger. The battery is only charged when the main switch on the electrical cabinet is in position 1 or 2.
5. Switch on the remote control, and establish contact with the crane again.



Step 2



Step 4



See the table below for the meaning of the LEDs.

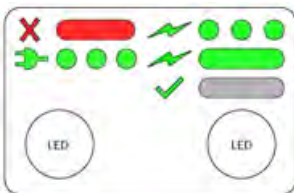

Left LED (charger status, fault only)		Right LED (battery status, user)	
LED status	Meaning	LED status	Meaning
Short green flash every 5 s	12 V connected	LED off	Battery not connected
Continuous red	Fault	LED continuous green	Battery charging 1 A
		LED flashing green	Charging 0.3 A
		LED off	Battery fully charged

4.3.2 Calibrating levers

If the levers of the remote control do not respond over the entire range of movement, they must be calibrated. Calibrating the levers can also be the solution when there is no connection with the crane, i.e. the LED on the **Link remote control and crane / sound horn** button is not flashing.

Start the calibration as follows:

1. Switch on the remote control with the **On/Off** button, and activate the remote control menu by pressing the **Confirm** button.



2. Press the **Down arrow** button to move the arrow in the display until it points to *Lever calibration*.

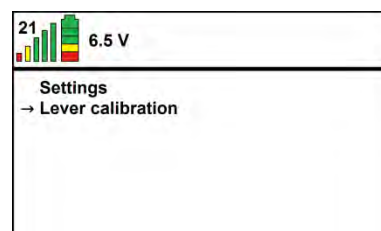

3. Press the **Confirm** button. The *Calibrate levers* screen appears with a bar for each lever.

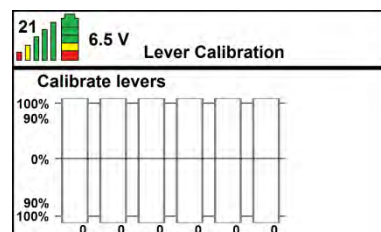

When you operate a lever the bar turns green. In the maximum position the bar should be 100% green. If not, the levers must be calibrated.

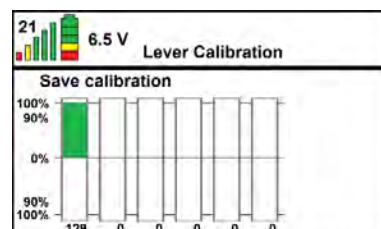

The screen shows six bars, with each bar representing a lever. When you operate a lever the bar turns green. When the lever is at its farthest position, the bar should be 100% green. If it does not reach 100%, the levers must be calibrated.

To calibrate the levers:

1. Press the **Confirm** button. The text *Put levers in center* is now displayed.

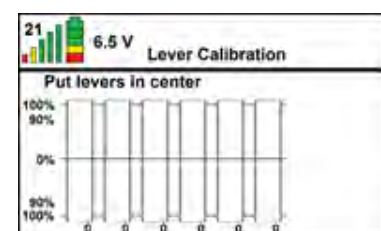

2. Set all levers to the centre position and press the **Confirm** button.



3. The text *Move levers back and forth* is now displayed. Slowly move the levers one at a time: first all the way forward and then all the way back.

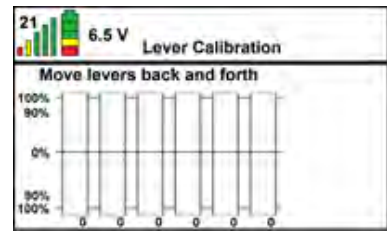

4. Press the **Confirm** button. The text *Save calibration* is now displayed.

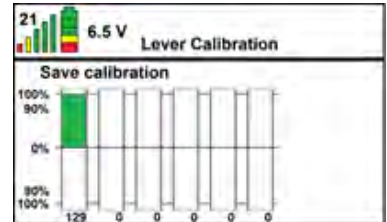

5. Move the levers one by one to check that the bar turns 100% green. Move the levers all the way in both directions.

6. Press the **Confirm** button to confirm the calibration. The settings are saved.



7. Press the **Back** button twice to return to the home screen.



4.4 Starting and switching off the crane

For an explanation of the remote control, see section *Remote control*.

Starting the crane

Start the crane as follows:

1. If you want to charge the battery while you work, plug the charging cable into the socket. This is not necessary if you do not want to charge the battery while you work.
2. Check that all levers of the remote control are in the centre position. If one or more levers are not in the centre position, no connection can be made with the crane.
3. Set the main switch on the electrical cabinet to position 1 or 2.
4. Switch the remote control on with the **On/off** button.
5. Activate the remote control with the **Link remote control and crane / sound horn** button.



Switching off the crane



WARNING

Never use the emergency stop button to switch off the crane during normal operation.

Switch off the crane as follows:

1. Put the crane in the transport position or any other desired position.
2. Switch off the remote control.
3. Set the main switch on the electrical cabinet to position 0.
4. If necessary, connect the crane to the mains.

Moving the crane

Move the crane at the job site with the jib stowed under the boom or hung beside the boom when the jib is not in use. For more information, see section *Putting the crane in transport position*.

4.4.1 Starting the crane via 230 V connection

If the crane's 24 V batteries are discharged, you can start the crane via the 230 V connection:

1. Press the emergency stop button.
2. Connect the plug of the charging cable to the socket.
3. Wait until the battery level bargraph shows that the batteries are being charged. For more information, see section *Charging 80 V batteries*.
4. Start the crane.

4.5 Moving the crane



DANGER

It is prohibited to drive the crane when the counterweight is extended, as this can cause the crane to tip over backwards.



DANGER

The crane can tip over if it is extremely tilted. See the permitted values.



DANGER

It is forbidden to be beside the crane while driving, due to instability.



WARNING

Always operate the crane with extreme care. Avoid abrupt movements and maintain contact with any signal men.



WARNING

It is forbidden to drive through water more than 10 cm deep.



WARNING

Always drive with the crawler tracks extended; this minimises the load on the ground and ensures maximum stability of the crane.



WARNING

If the situation necessitates that the crawler tracks be retracted, take extra care.



WARNING

It is forbidden to pull with boom and jib, both horizontally and vertically, such as pulling out poles or dragging loads. The crane is intended for vertical transport of loads subjected only to the pull of gravity. Towing loads with the drawbar eye is permitted while driving.



REMARK

When driving the crane on soft or sloping ground, keep the outriggers 10 cm above the ground to mitigate the risk of tipping over.

Maximum slope angles when driving the crane

Make sure that the crane is travelling on as flat a surface as possible. If you do have to drive on a slope, observe the following maximum values.

Direction of movement	Maximum slope angle
Forwards	15°
Backwards	23°
Sideways – crawler tracks retracted	15°
Sideways – crawler tracks extended	23°

4.5.1 Driving the crane



WARNING

Only drive the crane when it is in the transport position.



WARNING

Make sure when driving up a slope (e.g. via the lifting plate on a transport device) that the piston legs on the lowest edge are folded over to prevent the crane from tipping over. This also applies when the crane is driven down.

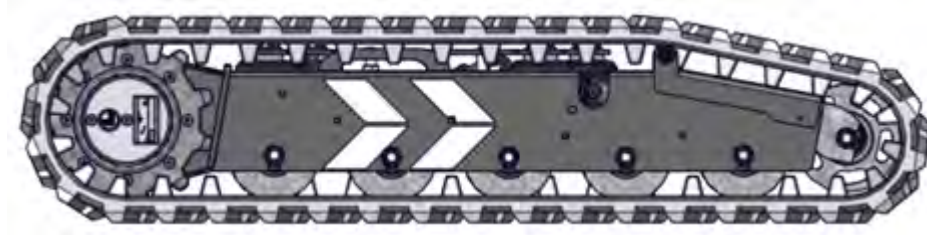

Figuur 4.3 Forward direction of travel is indicated by white arrows

Inspection

If you want to charge the battery while you work, plug the charging cable into the socket.



WARNING

Make sure the charging cable is not too short if it is left in the mains socket while driving the crane.

Drive as follows:

1. Check that all levers of the remote control are in the centre position.
2. Make sure that the crane is collapsed and unloaded.
3. Set the main switch on the electrical cabinet to position 1.
4. Switch the remote control on with the **On/off** button.
5. Activate the remote control with the **Link remote control and crane / sound horn** button.
6. Operate levers 3 and 4 on the remote control simultaneously forwards or backwards to drive. The direction of travel is indicated by the white arrows on the undercarriage. Operate one of the two levers to change direction.
7. Stop the crane by releasing the levers; they return to the centre position automatically.



4.5.2 Crawler track width adjustment

**WARNING**

Make sure the crane is raised on the outriggers so the crawler tracks are able to move freely.

**WARNING**

Avoid contact with the outriggers when setting or retracting the outriggers (crushing danger).

Adjust the crawler track width as follows:

1. Raise the crane on the outriggers.
2. Press the **Extend tracks/counterweight** button on the remote control to extend the tracks.
3. Press the **Retract tracks/counterweight** button on the remote control to retract the tracks.
4. Use only the maximum and minimum settings when configuring the crawler track width.



4.6 Setting the outriggers

**WARNING**

Make sure the outriggers are not extended too far, to prevent contact between the counterweight and outriggers during slewing.

**WARNING**

Make sure the chassis is horizontal, with a maximum tilt of 5°, to prevent instability.

**WARNING**

Do not raise the crane higher on the outriggers than necessary; once the crawler tracks have been lifted off the ground it is high enough.

**WARNING**

Assess the ground condition and use outrigger pads to reduce the ground pressure.

**WARNING**

Make sure the outrigger foot sits in the recessed circle on the outrigger pad when setting the outriggers. This is particularly important when raising high on the outriggers, in connection with the folding legs.

**WARNING**

Check that the crane is collapsed.

4.6.1 Display while setting the outriggers

While setting the outriggers, the remote control display shows how much can be lifted and the position of the crane.

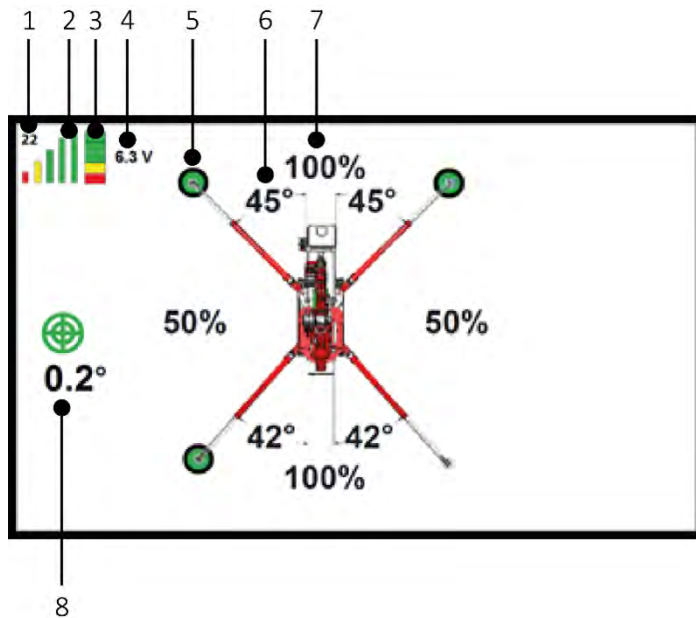

Figuur 4.4 Display while setting the outriggers

No.	Function	Explanation
1	Channel	The channel on which the remote control communicates with the crane.
2	Signal strength	If the strength is good, five bars are shown. As the signal weakens, the green bars disappear first, then yellow and red.
3	State of charge of remote control battery	A fully charged battery is indicated by five blocks. As the battery discharges, the blocks go out, one at a time.
4	Voltage	The voltage of the remote control battery is shown in volts.
5	Green mark	A green mark will appear at the end of the outrigger once the outrigger is placed correctly.
6	Outrigger angle	The angle of the outrigger in relation to the crane is shown separately for each outrigger.
7	Lifting capacity	The permitted lifting capacity in per cent. This value is determined, in part, by the angles of the outriggers. The permitted lifting capacity is shown on each side of the crane.
8	Horizontal position	The green circles indicate how level the crane is. The figure shows a value of 0.2°. This means the crane is 0.2° out of level. Use the spirit level on the crane to determine in which direction.

4.6.2 Setting outriggers



DANGER

Outriggers may only be used on a suitable surface.



WARNING

Maintain a close watch on the active outrigger during extension to prevent foot entrapment.



WARNING

Hydraulic extension is only possible if all the outriggers are raised off the ground. Otherwise, the extension system will be damaged.



DANGER

Do not put all of the outriggers in line with the crane (<math>< 5^\circ</math>). The crane will topple very easily.

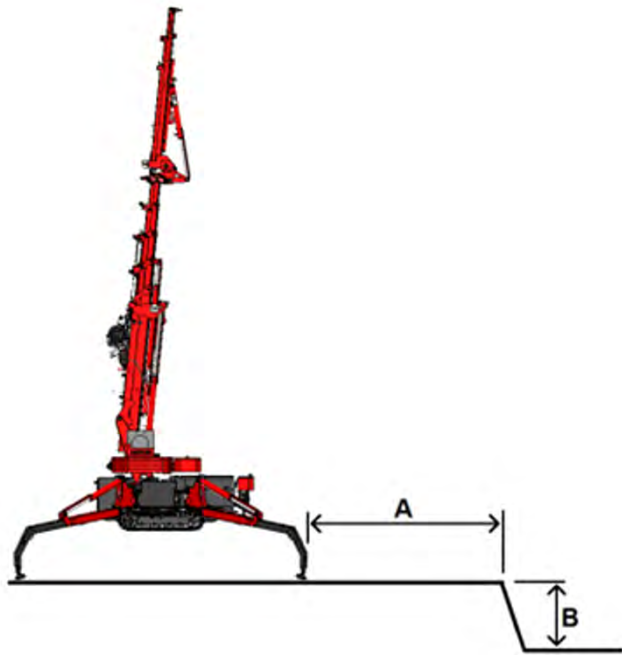

Figuur 4.5 Position near a slope

Preparation

1. Make sure the ground has sufficient load bearing capacity.
2. When the crane is near a ditch or slope, make sure that the distance from the outrigger to the edge (A) is at least twice the depth of the ditch (B), (see *Figuur 4.5*).
3. Set the crane in the ideal position. Consider safety, obstacles in the operating radius, outreach of the load, capacity and the limits of the crane.
4. Make sure that people who need to be present in the crane's operating radius – to give instructions and guide the load, for example – can work there safely.
5. To operate the outriggers, the following conditions must be met: boom angle less than 40°, boom length (cylinder extension) less than 200 mm, counterweight retracted.

Execution

1. Set the main switch on the electrical cabinet to position 1.
2. Switch on and activate the remote control.
3. Press the **Release left outriggers** and **Release right outriggers** buttons to release the outriggers.
4. Manually swing the outriggers to the desired position, preferably 48.5°. Release the button to lock the outriggers.



5. Check the outrigger angles on the display of the remote control.
6. Lower the outriggers with the levers of the remote control until they are horizontal.
7. Extend the outriggers:

Hydraulically: Press the **Release right outriggers** button together with lever 1 or 2 for the left side, and press the **Release left outriggers** button together with lever 5 and 6 for the right side.



If the crane is on a slope, it can be useful to operate the lever first and then press the button to prevent the outriggers from swinging unintentionally. Now first release the button and then the lever.



Manually: Release and pull out the extendable section until you reach the end of the mark, i.e. the white stripe, and then lock it (see *Figuur 4.6*). Outriggers may only be used fully retracted or fully extended.

8. Lower the outriggers one by one until they hang just above the ground. Maintain a clear view of the operated outrigger.
9. Place the outrigger pads under the outrigger feet so the outrigger foot falls in the recess of the outrigger pad. Also check the ground in the immediate vicinity for unevenness, loose material, slope and other issues that can affect the stability.
10. Fully lower the outriggers onto the outrigger pads.
11. Now operate the outriggers at the front simultaneously so the crane is just lifted off the ground.
12. Operate the rear outriggers simultaneously until the crane is level.
13. Check whether the crane is level and correct as necessary. The bubble in the spirit level must be in the centre of the circle (see *Figuur 4.7*).
14. Check whether all the outriggers are in contact with the ground and correct as necessary.



Figuur 4.6 Releasing extendable outrigger section



Figuur 4.7 Levelling the crane

Inspection

1. Check the outrigger angles and length on the display of the remote control.
2. Check that the crane is level after the outriggers have been set.
3. Check whether all the outriggers are in contact with the ground after they have been set.

4.6.3 Using nodding outriggers (optional)

Do the following to extend the nodding outrigger:

1. Remove the lynch pin from the nodding tube.
2. Pull the nodding section all the way out by hand until it contacts the end stop.
3. Lower the nodding section.
4. Fit the lynch pin.

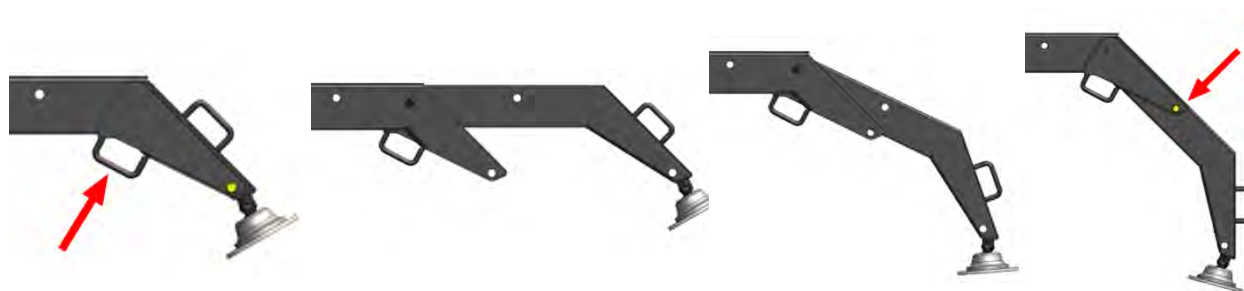

Step 1

Step 2

Step 3

Step 4

4.7 Lifting



REMARK

In case of overload, retract the extendable sections of the crane until the load is once more within the safe operating radius of the crane.

4.7.1 Display during lifting

During lifting, the remote control display shows how much can be lifted and the position of the crane.

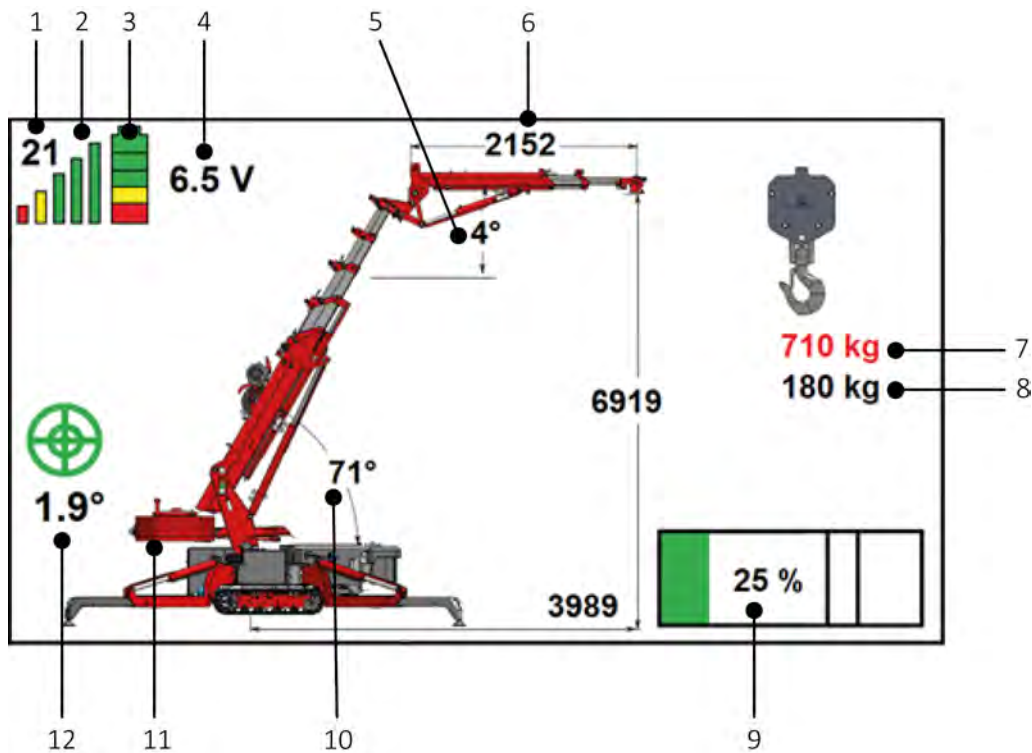

Figuur 4.8 Display during lifting

No.	Function	Explanation
1	Channel	The channel on which the remote control communicates with the crane.
2	Signal strength	If the strength is good, five bars are shown. As the signal weakens, the green bars disappear first, then yellow and red.
3	State of charge of remote control battery	A fully charged battery is indicated by five blocks. As the battery discharges, the blocks go out, one at a time.
4	Voltage	The voltage of the remote control battery is shown in volts.
5	Jib angle	The angle (in degrees) of the jib in relation to the horizontal axis.
6	Length	The lengths are shown for: - the length of the (extended) jib: 2152 mm - the lifting height: 6919 mm - the outreach: 3989 mm

No.	Function	Explanation
7	Maximum lifting capacity	The maximum lifting capacity in this position.
8	Load weight	The weight of the load hanging from the crane.
9	Load	Crane load in per cent of capacity
10	Boom angle	The angle (in degrees) of the boom in relation to the horizontal axis.
11	Counterweight position	The position of the counterweight shows whether the counterweight is retracted, extended or removed.
12	Horizontal position	The green circles indicate how level the crane is. The figure shows a value of 1.9°. This means the crane is 1.9° out of level. The spirit level on the crane indicates the direction.

4.7.2 Extending/retracting counterweight



DANGER

Stay away from the counterweight, particularly during retraction of the counterweight (risk of crushing).

The counterweight can be retracted and extended when the crane is supported on the outriggers.

Extend and retract the counterweight as follows:

1. Set the main switch on the electrical cabinet to position 2.
2. Press the **Extend tracks/counterweight** button on the remote control to extend the counterweight.
3. Extend the counterweight fully. If the counterweight is not extended all the way, the crane will operate as if the counterweight were completely retracted.
4. Press the **Retract tracks/counterweight** button on the remote control to retract the counterweight.
5. On the display of the remote control, the image shows the position of the counterweight.



4.7.3 Guiding the load

**WARNING**

Make sure the crane and track undercarriage are parallel to one another before collapsing the crane!

**REMARK**

In case of overload, retract the extendable sections of the crane until the load is once more within the safe operating radius of the crane.

Adhere to the following regulations when guiding a load:

- Always operate the crane with the load very carefully and only at the slow driving speed.
- Make sure the load is properly secured and will continue to hang stably.
- Never place body parts under the load or between the load and surrounding obstacles.
- Stand behind the load when it moves horizontally.
- Use protective clothing and safety goggles when working near or with fragile materials where there is a risk of splinters, such as stone and glass.
- Maintain visual contact and open channels of communication between the signal men and operator.
- Whenever possible, use guide lines to maintain a safe distance.
- Always ensure that there is a clear escape route to get to safety.
- Never stand or hang on the load.
- Avoid abrupt movements of the crane.
- Make sure that the area is clean and tidy to minimise the risk of tripping and that the guide line will get caught and/or damaged.

4.7.4 Lifting the load

To lift a load, the levers of the remote control are used. Note the following:

- Slowly move the levers forwards or backwards.
- Do not operate more than one crane function at a time.
- In the highest position, the crane's LML may be triggered and indicate an overload. To get out of this situation, the override must be switched on and then load-reducing movements can be made. Once you have boomed down slightly, switch off the override.



REMARK

If the outriggers are parallel to the crane on the counterweight side, booming up will stop automatically at 60°.

4.8 Lifting with the winch

**DANGER**

Observe the maximum load of the winch. When the cable is not reeved: 1000 kg; reeved once: 2000 kg; reeved twice: 3000 kg. Where a reeved cable is used, it is prohibited to lift if the cables are twisted. Otherwise, the cable may break.

**DANGER**

Make sure the cable runs along the grooves in the sheaves and the slot in the winch head stop plate!

**DANGER**

Check the lifting cable for damage, wear, twists or kinks. If it does, replace the cable before use.

**WARNING**

Use the winch only for vertical lifting. There is a risk of overloading when lifting at an angle.

**WARNING**

Whenever possible, leave the winch weight attached to the lifting cable so the cable will be wound up more tightly.

**WARNING**

The winch will stop automatically when there are three turns of the lifting cable remaining on the winch drum.

Important points

For the correct selection of attachments and swivel hooks, see the information sections:

- *Winch head positions in adjustable section – with main boom*
- *Winch head positions in adjustable section – with jib*
- *Adjustable section limits*

No other use is permitted.

Please note the following points:

- Reeve the winch cable if the mass of the load exceeds the capacity of the winch. Use one sheave in the winch weight for 1 x reeving (two cables) and both sheaves in the winch weight for 2 x reeving (four cables). For reeving, see section *Attaching winch weight*.
- The lifting cable may get stuck under the counterweight tube with the boom at 85°; this risk can be eliminated by extending the counterweight.

- Make sure that both pins are attached and secured when using the winch head in the adjustable section.
- Push the winch weight backwards when lifting the winch weight from the engine shroud bracket. Be careful that the winch weight does not get caught on the support.
- When configuring the winch weight for reeving, be careful to remove the centring bush for the lifting hook while switching from two sheaves to one or no sheave. It should only be used when two sheaves are used in the winch weight.
- Any time tension on the lifting cable has been slack, check that the cable is still taut and neatly wound around the winch drum before operating the winch.
- When using the winch, keep in mind the limits of the various crane configurations.
- ATTENTION: The complete winch weight with hook weighs 33 kg. Do not move or lift the weight manually.
- With the exception of the winch weight, lifting hook and counterweight removal support, never pull on parts of the crane.
- Check the gauge for the winch cylinder. The indicator point on the plate must be between the points on the boom, as shown in the yellow circle (see *Figuur 4.9*). Contact your dealer or Hoeflon International B.V. if the gauge falls outside the level, in connection with incorrect lifting capacity.

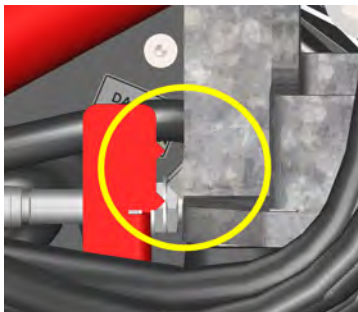

Figuur 4.9 Winch cylinder indicator point

4.8.1 Adjustable section limits



Figuur 4.10 Adjustable section upper limit

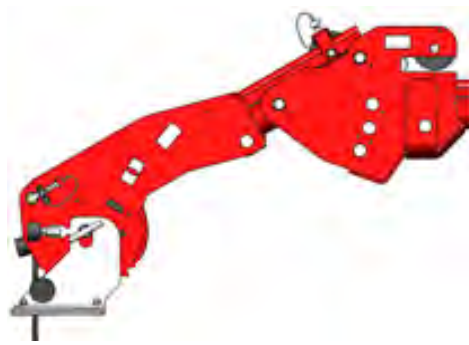

Figuur 4.11 Adjustable section lower limit

	Number of reevings	USE WITHOUT JIB		USE WITH JIB	
		Min. boom angle	Max. boom angle	Min. jib angle	Max. jib angle
Winch head without winch weight		Not permitted	Not permitted	Not permitted	Not permitted
Winch head	0	0°	70°	-70°	70°
	1 or 2	0°	45°	-70°	45°
Adjustable section with winch head lowered (see <i>Figuur 4.11</i>)	0	0°	85°	-40°	70°
	1 or 2	0°	85° or 85° with boom retracted	-70°	60°
Adjustable section with winch head raised (see <i>Figuur 4.10</i>)	0	0°	60°	-70°	60°
	1 or 2	0°	35°	-70°	35°

4.8.2 Maximum angle of main boom and jib

Winch head positions	Maximum angle of main boom	Maximum angle of jib
Winch head with winch weight reeved	$\leq 45^\circ$	$\leq 55^\circ$
Winch head with lifting weight and single cable	$\leq 60^\circ$	$\leq 70^\circ$
Winch head with adjustable section in upper hole with lifting weight reeved	$\leq 80^\circ$	$\leq 80^\circ$
Winch head with adjustable section in upper hole with lifting weight and single cable	$\leq 85^\circ$	$\leq 85^\circ$

4.8.3 Lifting without options

Inspection

1. Check that the winch plate is within the indicator range. The winch plate must not be crooked. When under tension, the winch plate must be between the indicator points.
2. Check the cylinder behind the winch for leakage.
3. Inspect the lifting cable for external deficiencies, such as kinks and broken strands.
4. Check that the lifting cable is wound neatly and tightly on the drum. If not, wind out the cable and then wind it in again tightly. Always use a weight when winding in.

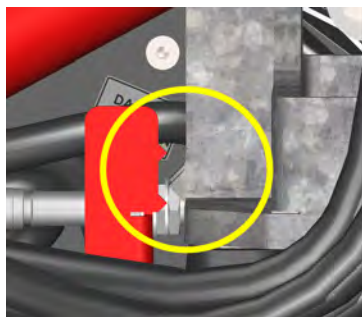

Step 1



Step 4

Preparation

1. Make sure the crane is supported on the outriggers, with the crawler tracks just above the ground.
2. Make sure the jib, jib adapter and/or other attachments have been removed from the boom and stored and secured in place.
3. Make sure the boom is horizontal and retracted.

Attaching winch head

1. Remove the winch head from the boom support.
2. Secure the boom adapter to the rear of the winch head with the lynch pin. Secure the pin.
3. Attach the winch head with the boom adapter to the boom with the lynch pin. Secure the pin.



Step 1

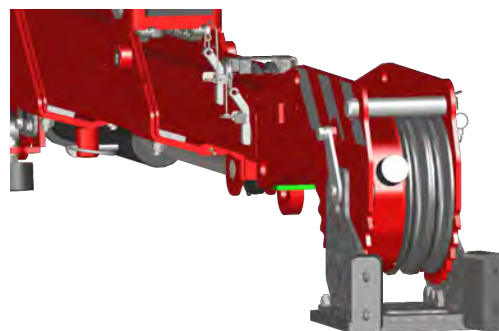

Steps 2 and 3

Activating winch control

1. Activate the winch control by pressing the **Confirm** button on the remote control. ✓
2. Now open settings by pressing the **Confirm** button. ✓
Then use the **Down arrow** button to select *Winch state* on the screen. Then use the **Right arrow** button to set *Winch state* to **ON**. ▼▶
3. After activating and setting the winch, return to the home screen by pressing the **Back** button. ↶

Execution

1. Start the drive system and activate the remote control.
2. Make sure the crane is supported on the outriggers and level.
3. Check whether the winch plate is between the indicator points. If not, contact your dealer or Hoeflon International B.V.
4. Set the main switch on the electrical cabinet to position 2.
5. Erect the crane and then extend the boom.

Running the cable



WARNING

The use of gloves is mandatory when running the lifting cable!

1. Use one hand to operate the lever for the winch on the remote control and the other hand to hold the lifting cable and keep it under tension.
2. Wind out the lifting cable until the end is about one metre in front of the crane. Keep the cable under tension while winding it out.
3. Switch off the remote control.
4. Run the lifting cable over the sheaves of the boom as shown in the figure. Check that the cable has been run over the sheaves correctly. There is an arrow engraved in the side of each sheave. These indicate how the cable is to be routed.
5. Run the cable over the winch head. First remove the upper pin (1) from the winch head. If you intend to lift with one cable, place the cable over the centre sheave and fit and secure the upper pin (1) in place again. Position the cable properly through the winch stop (2).

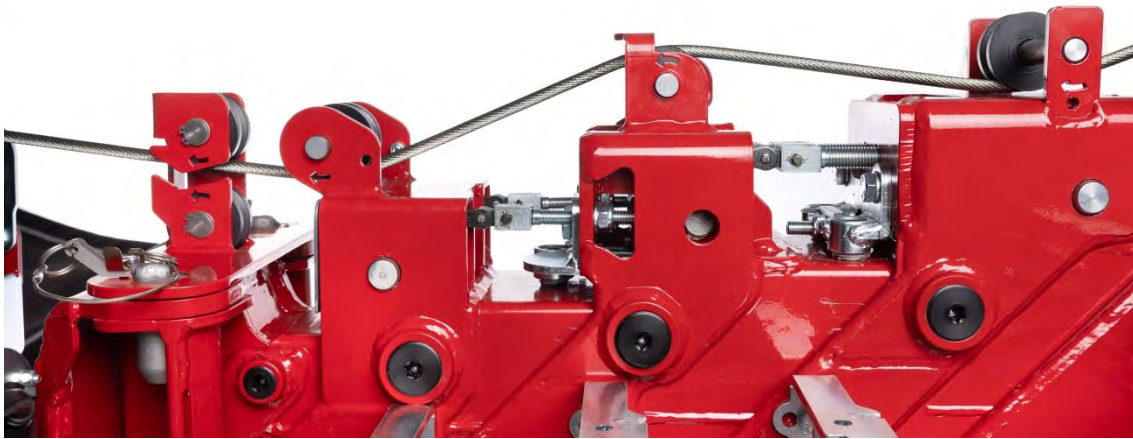

Step 4

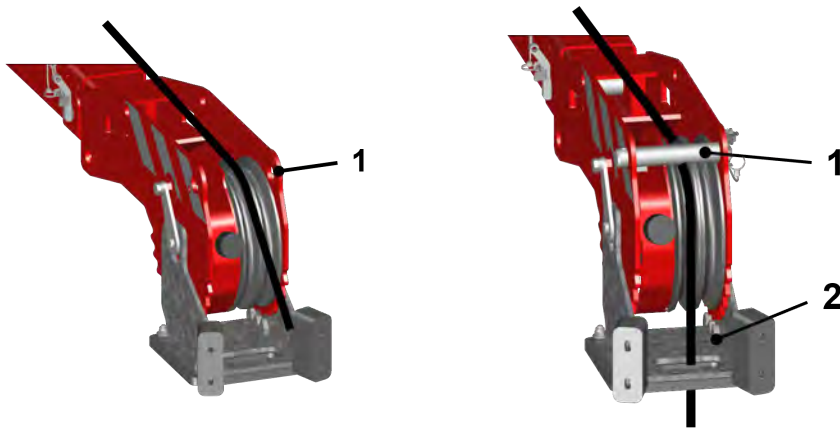

Step 5

Winding in the cable

1. After you have used the winch, wind the cable until the end is about one metre in front of the crane, pass it through the sheaves and then pull the cable tight and wind it up.
2. Hang the eye on the support and carefully wind in the cable and gently pull it tight.
3. Deactivate the winch by setting the *Winch state* to **OFF** in the remote control menu.

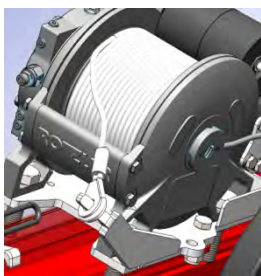

Step 1



Step 3

4.8.4 Lifting with jib

Preparation

1. Make sure the crane is supported on the outriggers, with the crawler tracks just above the ground.
2. Make sure the jib is correctly attached to the boom. For more information, see section *Removing and installing jib*.
3. Make sure the attachments have been removed from the jib and stored and secured in place.
4. Make sure the boom and jib are horizontal and retracted.

Attaching the winch head and running the cable

1. Remove the winch head from the support on the boom, and mount the winch head to the jib with the lynch pin. Secure the pin.
2. Use one hand to operate the lever for the winch on the remote control and the other hand to hold the cable and keep it under tension. Wind out the cable until the end is about one metre in front of the crane. Keep the cable under tension while winding it out.
3. Run the cable over the sheaves of the jib as shown in the figures. Check that the cable is running over the sheaves correctly. Refit the retainers.
4. Guide the cable over the winch head and mount the winch weight.

Inspection

1. Make sure all the pins and loose parts are properly attached and secured.
2. Make sure the cable does not get caught on the boom and jib structure.

With jib installed

1. Slide the cable through the opening between the two sheaves so the cable runs between the two sheaves. Insert the eye through the recessed support. Place the cable in the sheave by holding the cable in the upper notch and sliding the roller under it. Now the cable can drop into the roller, and the roller with cable can be slid back into the middle.
2. Pass the cable through the plastic slot so it runs through the hole.

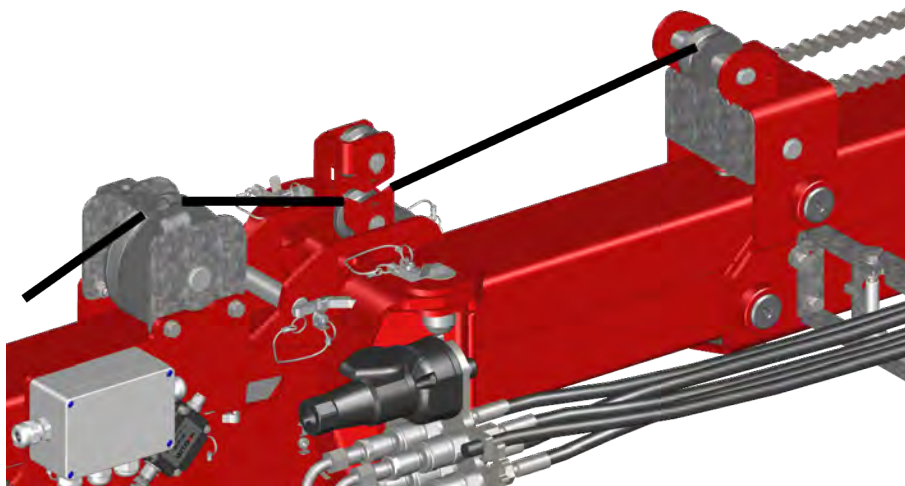

Step 1

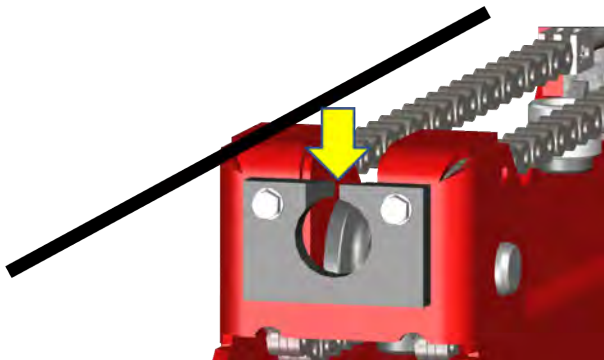

Step 2

3. Pull the cable over the winch head and follow the steps described above.
4. To remove the cable, perform the steps in the reverse order. Make sure the cable is wound up tightly by holding it while winding it up.
5. After removing the winch, fit a hook to a D-shackle if necessary. Fit the pin and secure it.

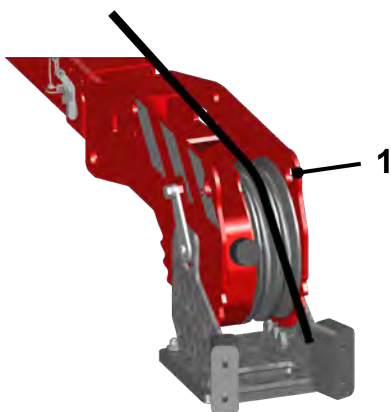

Step 3



Step 5

4.8.5 Lifting with adjustable section

Preparation

1. Make sure the crane is supported on the outriggers, with the crawler tracks just above the ground.
2. Make sure the jib is correctly attached to the boom, as described for use of the jib.
3. Make sure the attachments have been removed from the boom or jib and stored and secured in place.
4. Make sure the boom and/or jib are horizontal and retracted.

Attaching adjustable section

1. Remove the adjustable section from the boom support; fit the retainer. If it will be used in the boom, mount the boom adapter.
2. Mount the adjustable section to the boom or jib and secure it with the lynch pin. Secure the pin.

Attaching manual jib extension

1. Remove the manual jib extension from the counterweight weight.
2. Place the manual jib extension in the jib tube and lock it with the pin.
3. Or place the boom adapter so the manual jib extension can be placed directly in the boom and secure it with the lynch pin.

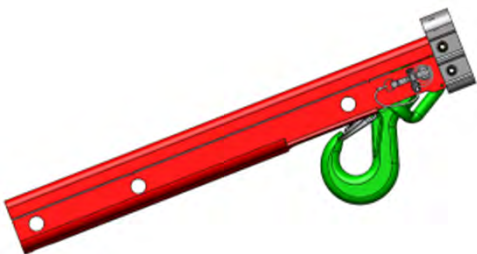

Figuur 4.12 Manual jib extension

Attaching manual jib extension in combination with adjustable section

1. Attach the manual jib extension to the adjustable section with the two pins and secure them.

4.8.6 Winch head positions in adjustable section – with main boom

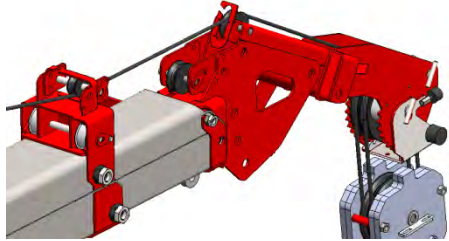
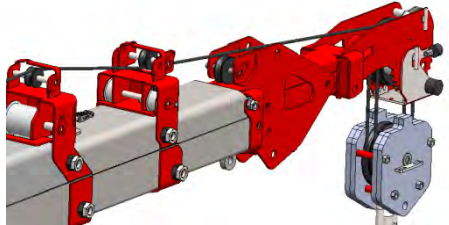
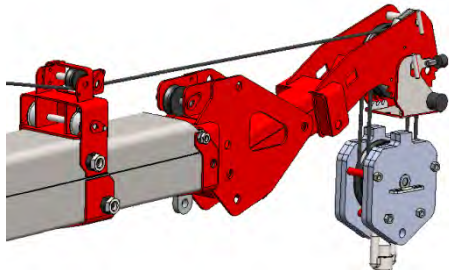
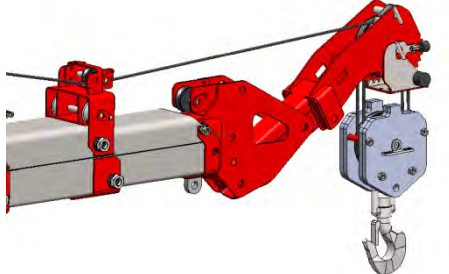
Main boom	
<p>Winch head in top hole. Cable over auxiliary pulley to rear of winch head.</p>	
<p>Winch head in second hole. Cable without auxiliary pulley to large sheave in winch head.</p>	
<p>Winch head in third hole. Cable without auxiliary pulley to large sheave in winch head.</p>	
<p>Winch head in bottom hole. Cable without auxiliary pulley to large cable sheave in winch head.</p>	

4.8.7 Winch head positions in adjustable section – with jib

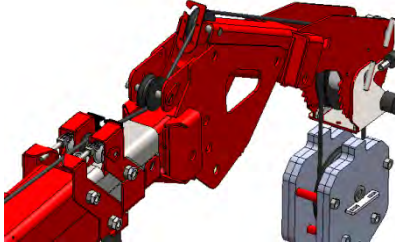
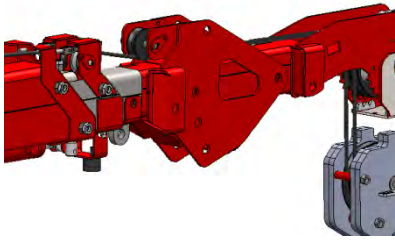
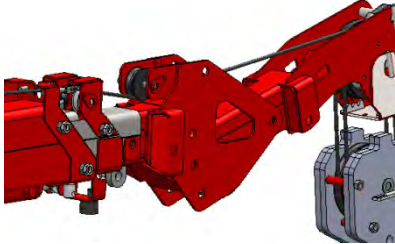
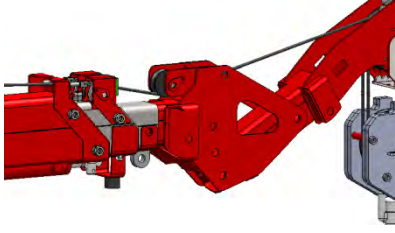
Jib	
<p>Winch head in top hole. Cable under auxiliary pulley of the adjustable section and over auxiliary pulley at rear of winch head, to large sheave in winch head.</p>	
<p>Winch head in second hole. Cable under auxiliary pulley of the adjustable section through to large sheave in winch head.</p>	
<p>Winch head in third hole. Cable under auxiliary pulley of the adjustable section through to large sheave in winch head.</p>	
<p>Winch head in bottom hole. Cable under auxiliary pulley of the adjustable section through to large sheave in winch head.</p>	

4.8.8 Attaching winch weight



DANGER

Observe the maximum load of the winch. When the cable is not reeved: 1000 kg; reeved once: 2000 kg; reeved twice: 3000 kg. Where a reeved cable is used, it is prohibited to lift if the cables are twisted. Otherwise, the cable may break.



DANGER

Make sure the cable runs along the grooves in the sheaves and the slot in the winch head stop plate!



WARNING

The winch will stop automatically when there are three turns of the lifting cable remaining on the winch drum.

Principle of cable reeving

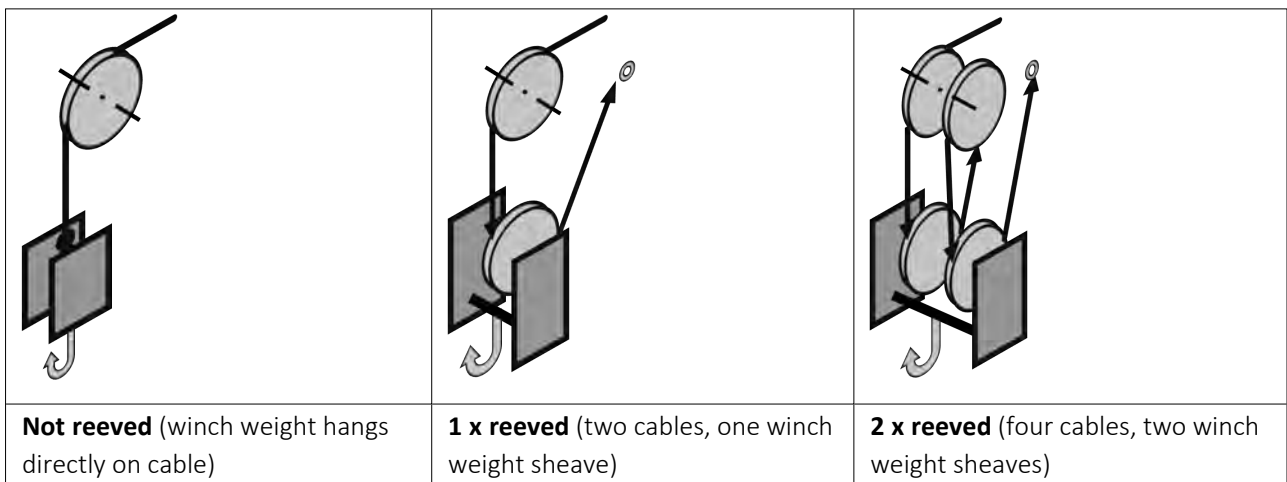

Figuur 4.13 Principle of cable reeving

Preparation

1. Make sure the crane is supported on the outriggers, with the crawler tracks just above the ground.
2. Make sure the winch head is mounted.

Attaching winch weight without reeving

1. Remove the lynch pin (1) from the winch weight.
2. Remove the front half (3) of the winch weight.
3. Remove the two sheaves (2).
4. Remove the centring bush (4).

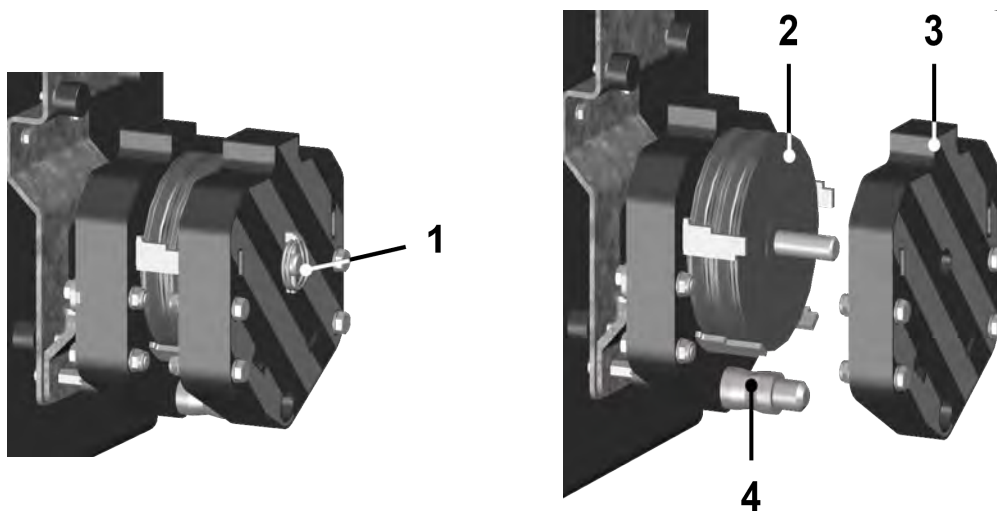

Figuur 4.14 Removing winch weight

5. Slide the lifting hook without the centring bush onto the pin (6).
6. Slide the eye of the lifting cable over the shaft (5) on which the sheaves were fitted.
7. Fit the front half (3) of the winch weight back in position.

ATTENTION: The front half must be placed the other way round. This half will now slide the rest of the way over the strips, and the eye of the lifting cable will be clamped between the two halves.

8. Fit the lynch pin (1) in the second hole in front of the front section of the winch weight to secure it in place.

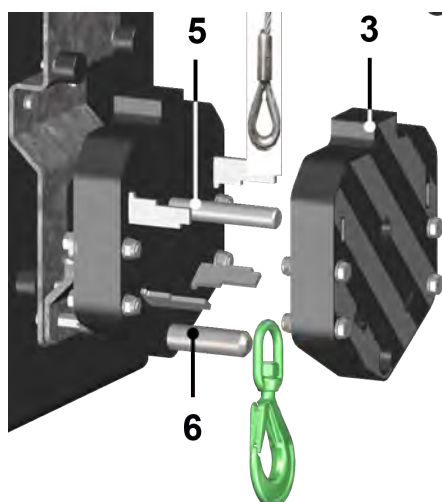

Figuur 4.15 Attaching lifting cable and lifting hook to winch weight

Attaching winch weight with 1 x reeving

1. Remove the lynch pin (1) from the winch weight.
2. Remove the front half (3) of the winch weight.
3. Remove a sheave.

4. Remove the lifting hook from the centring bush (4).
5. Slide the lifting hook without the centring bush onto the pin (6).
6. Attach the lifting cable to the sheave.
7. Fit the front half (3) of the winch weight back in position.
ATTENTION: The front half must be placed the other way round. This half will slide the rest of the way over the strips and almost contact the sheave.
8. Fit the lynch pin (1) in the second hole in front of the front section of the winch weight to secure it in place.
9. Pull the eye of the lifting cable along the inside of the winch head and place it over the black plastic with the recess. Remove the pin at the top of the winch head and fit it again with the pin through the cable eye.

Attaching winch weight with 2 x reeving

1. Remove the lynch pin (1) from the winch weight.
2. Remove the front half (3) of the winch weight.
3. Run the lifting cable around the first sheave and then around the outermost sheave of the winch head. Then around the second sheave of the winch weight.
4. Make sure the lifting hook is around the centring bush.
5. Fit the front half (3) of the winch weight back in position.
ATTENTION: The front half must be positioned so the sheaves can rotate freely. If the front half is positioned incorrectly, the sheaves contact the steel winch weight.
6. Fit the lynch pin (1) in the first hole in front of the front section of the winch weight to secure it in place.
7. Pull the eye of the lifting cable along the inside of the winch head and place it over the black plastic with the recess. Remove the pin at the top of the winch head and fit it again with the pin through the cable eye.

Inspection

1. Make sure all the pins and loose parts are properly attached and secured.
2. Make sure the lifting cable does not get caught on the boom and jib structure.

Execution

1. Switch on the remote control and position the lifting cable above the winch weight by raising the boom, slewing it if necessary and winding out the cable. Use one hand to operate the lever for the winch on the remote control and the other hand to hold the cable and keep it under tension.
2. Remove the pin from the removable half of the winch weight and remove this half.
3. Fit the required number of cable sheaves. For 0 x reeving do not use any sheaves. Attach the eye to the shaft that the sheaves were on.

4. Position the lifting hook and lifting cable, fit the removable half of the winch weight back in place and secure it.
5. Attach the loop of the cable to the winch head. The cable must enter the hole in the plastic from the inside of the winch head, and then the pin can go through the eye of the cable. Secure the pin.
6. Use one hand to operate the lever for the winch and the other hand to hold the cable and keep it under tension. Pull the cable until it is under tension.
7. Use one hand to push the winch weight backwards so it is no longer secured and use the other hand to operate the lever for the winch. See whether the winch weight can be lifted free of the support, and lift the winch weight off of the support.

4.8.9 Checking the winch stop

The winch is protected by the winch stop. Provided the winch weight is properly mounted on the lifting cable and the lifting cable is properly mounted in the winch head, the crane will stop winching if the winch weight touches the winch stop on the winch head. The figures below show how the lifting cable must be run in the winch head and the winch weight.

	Correct	Incorrect
1 cable		
1 x reeved		
2 x reeved		

5.

MAINTENANCE

5.1 Introduction

This chapter provides instructions for the maintenance that is necessary to ensure proper operation of the crane. It is very important that these instructions are followed, to ensure your safety and that of others who are present.

Unusual noises or vibrations can indicate a defect in the crane. It is then necessary to perform a repair or maintenance without delay. Please consult your dealer or Hoeflon International B.V.

Contact your dealer's technical department for additional information concerning aspects such as maintenance and repair of specific parts.

5.2 Warnings

**DANGER**

Never use your hand to locate a leak in the hydraulic system; use a piece of paper or cardboard instead. Oil under high pressure can penetrate the skin and cause poisoning.

**WARNING**

If you are unable to correct a malfunction, contact your dealer or Hoeflon International B.V.

5.3 Maintenance work

The risk of accidents with cranes is generally greater during maintenance, cleaning and service. Have your dealer perform the maintenance work on the crane. In the Netherlands you can choose to enter a maintenance contract with Hoeflon International B.V.. The maintenance intervals and activities are shown in the lubrication schedule and maintenance schedule.

5.3.1 Weekly maintenance

1. See maintenance chart.
2. Grease the crane in accordance with the lubrication chart.
3. Clean the crane with water and a mild cleanser such as car wash shampoo. Never use solvents or other flammable liquids as a cleanser. When spray cleaning, never aim directly at the engine or electrical parts.
4. Clean the crane daily after use in or transport through a salty/briny environment. Be sure to remove all the salt/brine, to prevent corrosion of the crane.

5.3.2 Monthly maintenance

1. See maintenance chart.
2. Grease the crane in accordance with the lubrication chart.

5.3.3 Scheduled service

1. The first scheduled service must be performed after 2 weeks or 50 hours of operation.
2. Thereafter the crane requires scheduled service annually or every 1000 hours of operation.
3. It must also be inspected annually. For the Netherlands, the following sticker is used to indicate when the next inspection is due.
4. It is recommended that you have the scheduled service and inspections performed by your dealer or Hoeflon International B.V..



Figuur 5.1 Maintenance sticker

5.3.4 First use

1. Perform the daily inspection.
2. Test the following aspects of the crane:
 - a. Operation of emergency stop buttons.
 - b. Operation of all functions.
 - c. Operation of safeguards.

5.4 Maintenance schedule

The maintenance schedule indicates which maintenance must be carried out and at what interval.

Description of maintenance	Action	Hours interval							
		Daily	First 50 hours	50	100	250	500	1000	4000
o = manufacturer/dealer, ● = owner									
Track undercarriage									
Tension of crawler tracks	Check/adjust			●					
Oil lever, crawler track motors	Check/top up					○			
	Replace						○		
General									
Crane	Clean			●					
Safety provisions + sensors	Check	●							
Lifting equipment (cables, hooks etc.)	Check/replace	●							
Control levers + emergency stop buttons	Check	●							
Condition and presence of pictograms	Check					○			
Mechanical components	Check	●							
Boom clearance	Check/adjust							○	
Turntable	Check/tighten		○				○		
	Lubricate			●					
Construction including pins, shafts etc.	Check					○			
Boom extension and retraction chains	Check/lubricate				●				
Plastic slide plates on boom	Check					○			
	Lubricate			●					
Boom guide bolts	Check					○			
Pivot points and extendable sections	Lubricate			●					
Bolt connections	Tighten						○		
Boom wear parts (completely disassemble)	Replace								○
Wiring connectors/voltage	Check					○			
Hydraulic system									
Hydraulic oil	Check	●							
	Replace							○	
Leaks	Check	●							
Hydraulic hoses	Check					○			
	Replace								○
Pressure levels	Check							○	
Hydraulic return filter/pressure filter	Replace		○				○		
Stop valves and pressure relief valve	Test							○	
Hydraulic system	Rinse								○
Electrical system									
Wiring connectors	Check					○			
Emergency stop buttons and sensors	Check	●							
Voltage	Check					○			

5.5 Lubrication chart

The lubrication chart indicates which parts need to be lubricated and at what interval. The instructions can be found further in this chapter.

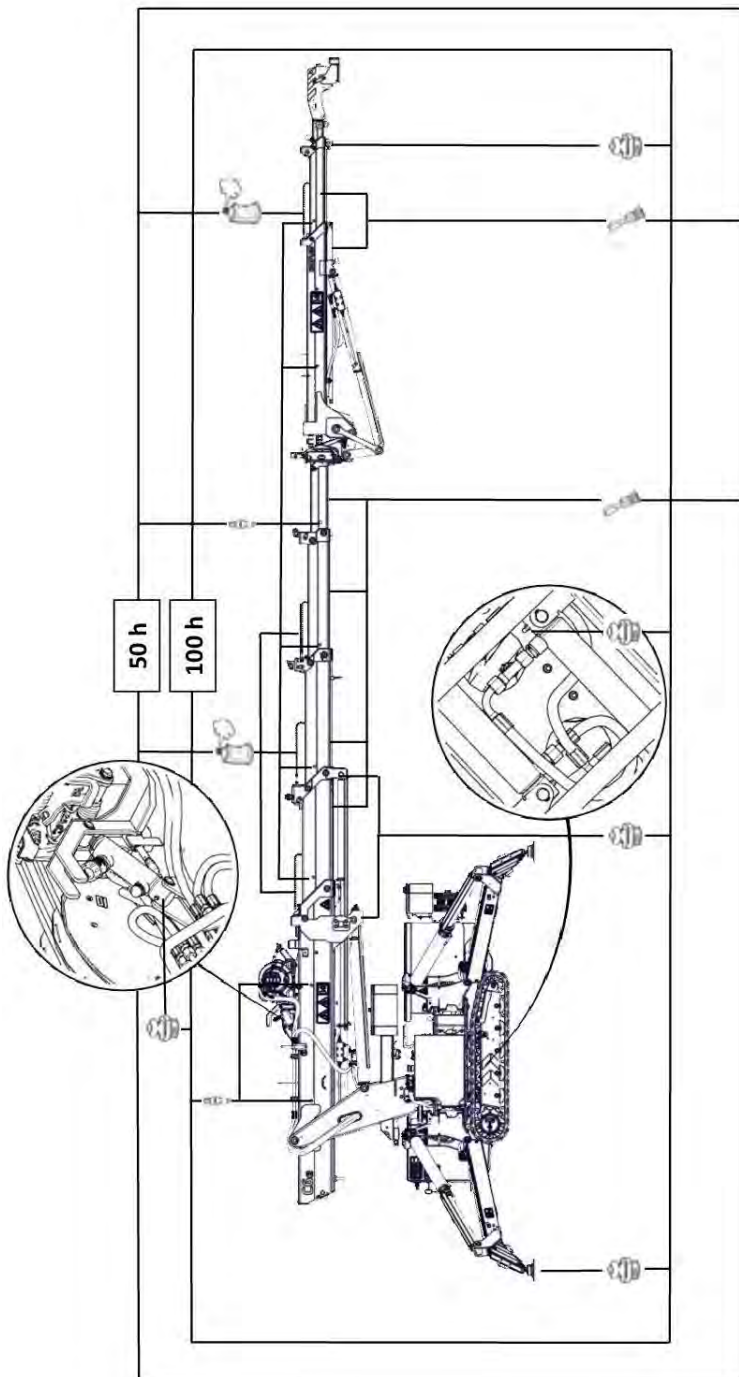

Figuur 5.2 Lubrication chart

5.6 Lubricate

Lubricate the crane as shown in the lubrication chart, paying particular attention to the following:

- Clean the grease nipples thoroughly before lubrication.
- Remove excess and old grease from the boom sections.
- Use clean greases, stored in sealed packaging.
- Lubricate the top side of the plastic guide on the boom by inserting a grease gun fitted with a nipple connector through the holes, when the boom is fully extended.
- Use only prescribed greases; see lubricant specifications.

5.6.1 Lubricants

Manufacturer	Hydraulic oil		Final drives
	Universal	Organic	
Q8	Heller 46	Q8 Holbein HP SE Bio 46	T55
Total	Equavis ZS 46	BioHydran TMP 46	EP-B 80W90
Shell	Shell Tellus S2/S3	Shell Naturelle HF-E 46	Spirax S3 AX 80W-90
Kroon oil	Perlus ZF 46	Perlus Biosynth 46	Gearlube GL-5 80W-90
Matrix		Hydromax HT ECO 46	

Also use the following lubricants:

- For lubrication points: EP2
- For chains: industrial chain spray
- For sliding parts: Interflon OG

5.7 Function mapping

This function allows you to assign different functions to the levers. As standard, it is set to *Default*. If you set the function to *Custom*, the levers work the same way as for many truck-mounted cranes. This position can be selected if preferred. Contact Hoeflon Service.

Do the following:

1. Switch on the remote control with the **On/Off** button, and activate the remote control menu by pressing the **Confirm** button.
2. Press the **Confirm** button to open the settings.
3. Press the **Down arrow** button to move the arrow in the display until it points to *Function mapping*.
4. Press the **Right Arrow** button and select *Custom*.



The alternate functions of the levers with the main switch in position 2 are as follows:

No.	Image	Function	Lever backwards	Lever forwards
1		Slew main boom	Left	Right
2		Boom up and down	Boom up	Boom down
3		Extend/retract main boom	Retract	Extend
4		Jib up and down	Jib up	Jib down
5		Extend/retract jib	Retract	Extend
6		Raise and lower winch	Raise	Lower

5.8 Charging 80 V batteries

Read these instructions carefully to familiarise yourself with how to handle the batteries correctly.

It is of paramount importance that personnel closely observe these warnings and precautions to prevent injury to themselves and others and damage to the equipment.

**DANGER**

Do not open or disassemble the batteries or charger.

**DANGER**

Disconnect the battery when replacing electrical components.

**WARNING**

To charge the crane, use a cable with a minimum conductor cross-sectional area of 2.5 mm² and a maximum length of 25 m.

**REMARK**

After operating the emergency stop button, the crane must be reactivated. To do so, turn the main switch on the electrical cabinet to position 0 and then to position 1.

5.8.1 Battery level bargraph

The crane is fitted with a battery level bargraph (1) that shows the state of charge (SOC) and charging mode (M) of the battery packs. The location of the battery level bargraph on the crane is indicated by the pictogram (2) (see *Figuur 5.3*).

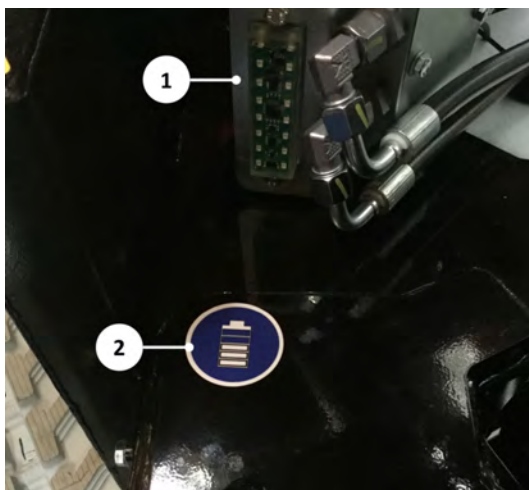

Figuur 5.3 Battery level bargraph and pictogram

When the crane is connected to the mains and the charger is active, the upper LED bar flashes, so the current SOC value will be lit continuously. If the crane is not connected to the mains, the SOC is displayed when the main switch on the electrical cabinet is in position 1. When the main switch is in position 0, nothing is displayed but charging does take place. For cranes with older software, this works slightly differently.

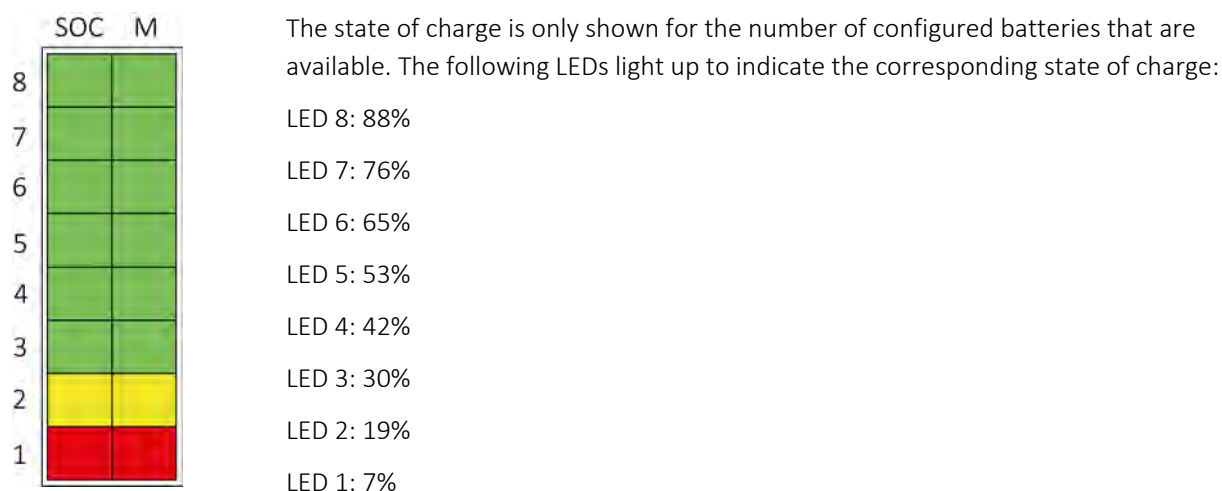

Figuur 5.4 Battery level bargraph with SOC (state of charge, left) and M (charging mode, right)

The following table shows the different charging modes:

Mode	Battery level bargraph
Fast charging (>2A per battery)	The battery level bargraph fills every 4 seconds
Balance charging: All cells are equalised to ensure the battery is charged to maximum capacity.	The battery level bargraph fills every 16 seconds
If all the batteries have been fully charged since the charging plug was connected.	All the LED segments are on

When the crane is switched off, the battery level bargraph shows the status and mode as long as the charging plug is connected to the mains.

5.8.2 Charging the batteries

**REMARK**

Charge the batteries at the end of each day to keep them balanced and in good condition. Condition: The emergency stop buttons must not be pressed, and the main switch on the electrical cabinet must be in position 0.

**REMARK**

When the crane's key switch is off, the priority is on charging the batteries. When the key switch is on, charging continues while the crane is lifting. Then the priority is lifting. The batteries will still be charged, but less efficiently and less quickly. This can also cause a pack to not be charged at all, with the risk that it will become fully discharged.

To charge the batteries:

1. Set the main switch on the electrical cabinet to position 0.
2. Check that the charging cable plug is clean and dry.
3. Connect the plug to the mains socket. Charging starts automatically.
4. During charging, the battery level bargraph fills up. When the state of charge is above 88%, all LEDs in the SOC column are lit.
5. When the batteries are fully charged, all the SOC LEDs are lit.
6. Disconnect the charging cable from the mains supply and store it in the crane again.

Read chapter *TRANSPORT, STORAGE AND DISPOSAL* for instructions on battery maintenance when the crane is placed in storage.

5.9 Using emergency charging points

The emergency charging points are intended for the 24 V system.

Preparation

Make the following preparations:

- Obtain a start assistance source with the correct voltage and sufficient capacity that is fit for purpose and place it as close as possible to the crane, yet at a safe distance.
- Obtain suitable start assistance cables with sufficient length and thickness and intact insulation, fitted with good, preferably insulated clamps.
- Make sure the area is safe, without any water or conductive materials. Make sure there are no loose parts on the crane or that may fall on the machine.
- Place insulating material to prevent indirect contact with the + terminal (behind red protective cap) and chassis.
- Remove the remote control battery from the charger on the crane to prevent damage.

Procedure

Use the emergency charging points as follows:

1. Make sure the crane is switched off.
2. It is a 24 V system, so use a 24 V charger or vehicle.
3. Place insulating material between the chassis and + emergency charging point, if necessary.
4. Make sure the start assistance cables are connected to the emergency charging points correctly.
5. Always hold the + start assistance cable in your hand, prevent contact and do not place it near the – start assistance cable clamp.
6. Prevent the start assistance cables from becoming twisted together; separate them from each other.
7. First connect the + start assistance cable by clamping it firmly to the + charging terminal (with the red protective cap). Ensure that the clamp cannot contact the chassis or the – charging terminal (*Figuur 5.5*).
8. Connect the start assistance cable.
9. Verify that the clamps are correctly attached and making good contact.
10. Switch on the key switch of the crane.
11. Allow the crane to recharge for a few minutes.
12. Switch on the crane so it is in operation.
13. Switch off the start assistance source and remove the start assistance cables in the reverse order.
14. Place the protective caps back on the emergency charging points. Replace them if they are damaged.



Figuur 5.5 Emergency charging points

5.10 Maintaining the boom chains

Please note the following when maintaining the chains:

- Do not repair chains or insert new links; if deficient, have them completely replaced by your dealer or Hoeflon Service.
- If there are two extension or retraction chains, replace both, along with the connections, at the same time.
- If the chains are soiled to the point that lubrication no longer helps, clean with petroleum ether or diesel. Do not clean with acidic agents or a pressure washer. These can damage the chains.
- Check the chain regularly for lubrication, rust, breaks in the pins/plates and wear.
- Lubricate the chain every 100 hours (see section *Maintenance schedule*).

5.11 Removing and installing jib

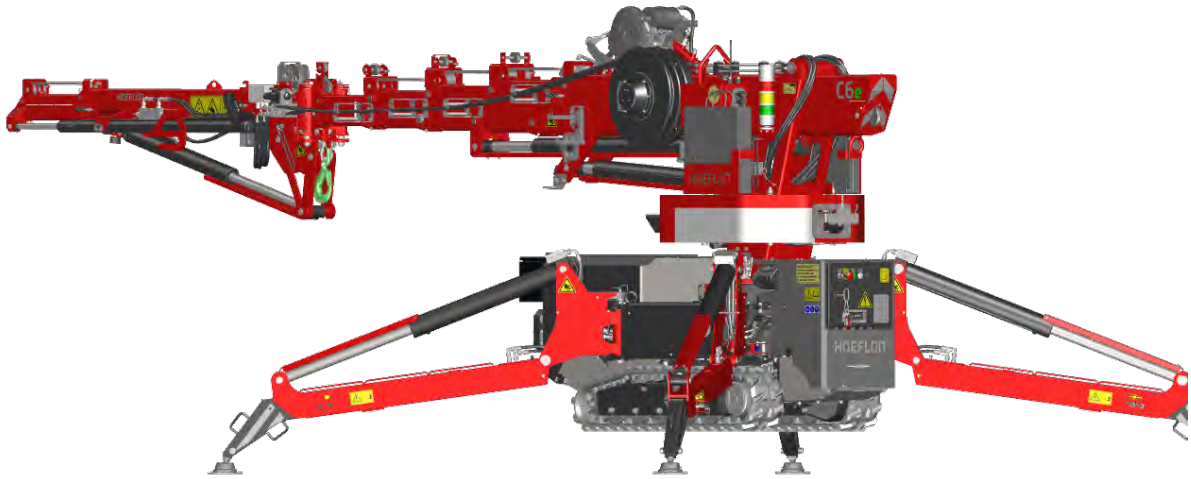

1. Set the boom and jib horizontal. Make sure the boom is positioned slightly above horizontal. This makes it easier to slew the jib.

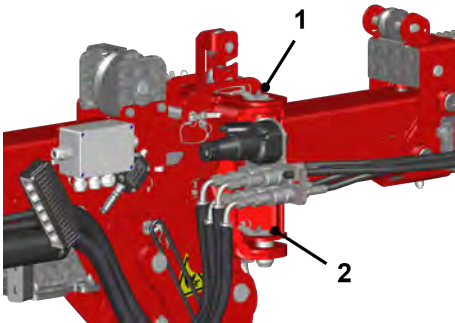

2. Remove the two pins (1 and 2) from the left side of the hinged section of the jib
3. Slew the jib 180° so it hangs parallel to the boom.



4. Fit the D-shackle (3) on the main boom to the eye on the jib. To do this, raise the jib until it can be attached to the D-shackle. Secure the D-shackle.

The jib is now hanging from the D-shackle and can be moved easily.

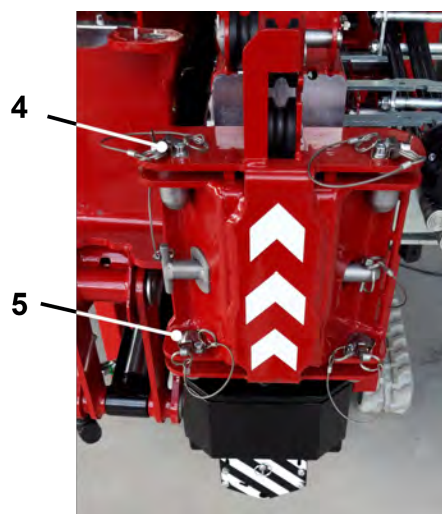

5. Remove the two pins (4 and 5) from the right side of the hinged section of the jib. Lower the jib when you do this so it is easier to remove the pins.
6. Guide the jib with the shaft on the underside of the boom into the corresponding section (6) of the main boom and lock it in place.

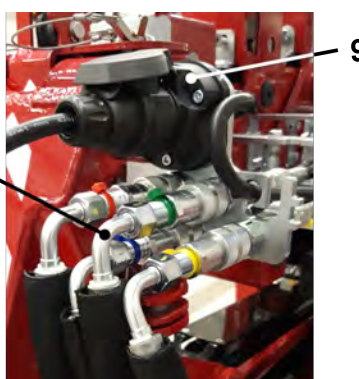

7. Place the eye of the lever closure (7) over the hook on the jib and latch it.
8. Disconnect the hydraulic hoses (8) and power plug (9). Secure the loose hoses to the jib.

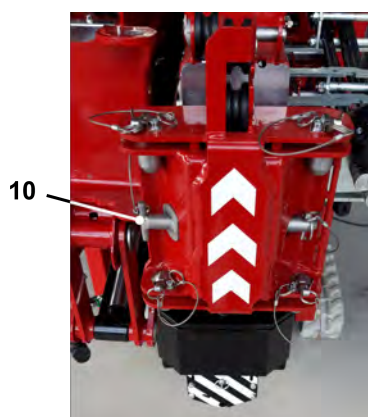

9. The fixed section of the jib can be removed from the boom, if necessary, by removing the pin (10) and manually pulling the section out of the main boom. It is also possible to work with the crane if the fixed section of the jib is still in the boom.
10. To install the jib, perform the steps in reverse order.
11. Do not forget to secure the pins!

5.12 Removing and installing counterweight

**WARNING**

Stow the removable support after mounting the counterweight. Otherwise, the support will contact the column during retraction.

**WARNING**

Never stand within the slewing range of the counterweight. During extension, never stand within sliding range of the counterweight (risk of crushing).

**WARNING**

Be careful not to damage the crane while removing the counterweight.

5.12.1 Removing counterweight with your own equipment

Preparation

- Make sure there is nothing within a radius of approximately 10 m.
- Make sure the crane is supported on the outriggers in a square configuration, with the crawler tracks just above the ground and no load on the hook.
- Make sure there is enough space for the boom to be extended to one side (preferably the right side) so the counterweight can be removed on the left side (because the sensors are on the right side).
- Make sure the crawler tracks are retracted.
- Make sure the boom is horizontal.
- Make sure the counterweight is placed in a safe spot, not on walking or driving paths and not within the operating radius of the crane or the working area of other machines or employees.

Required tools

- 10 mm hex key or ratchet spanner
- 24 mm combination spanner or ratchet spanner

Execution

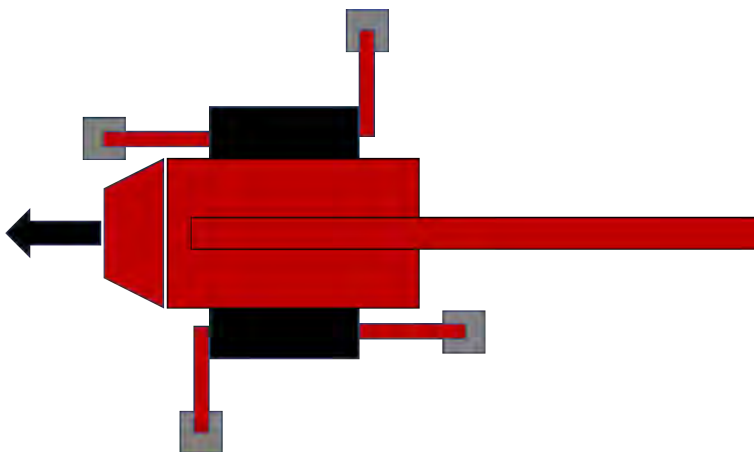

Figuur 5.6 Schematic top view of crane

1. Extend the outriggers and position the boom at right angles to the crane with counterweight to the left (see Figuur 5.6).

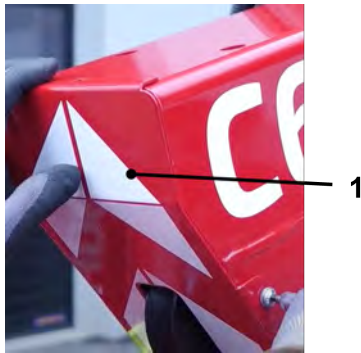

2. Extend the counterweight with the **Extend tracks/counterweight** button on the remote control.
3. Remove the rear cover (1) of the boom with a 10 mm hex key.
4. Extend the boom slightly (remote control lever 2 forward) and switch the control off.
5. Take the counterweight support (3) out of the storage position and mount and secure it in the counterweight removal position.

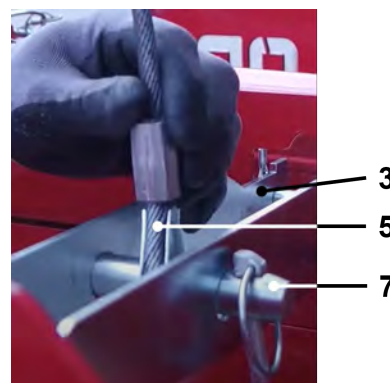
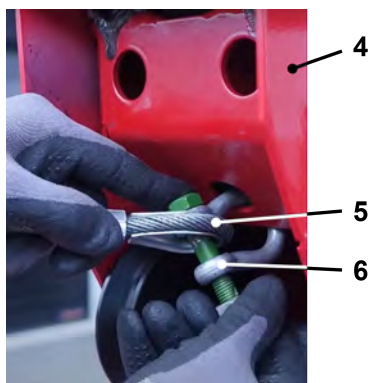

6. Attach the counterweight removal cable (5) to the back of the outermost sliding boom section (4) with a bow shackle (6).
7. Fit the other side of the cable (5) to the pin (7) in the counterweight support (3) and secure the pin. Make sure the cable is not twisted and does not have any loops and windings.

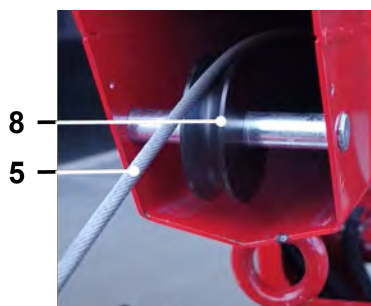

8. Switch the remote control on and extend the boom until the counterweight removal cable (5) is just under tension. Make sure the cable is guided over the sheave (8) correctly. Also be careful that the front of the boom does not contact anything.
9. Take off the counterweight retainer by removing the two hex head bolts (9) with a 24 mm spanner.

Remove the silver coloured plate (10) that was held by the bolts.



10. Extend the boom slightly until the counterweight (11) hangs completely from the counterweight removal cable (5).
11. Fully retract the counterweight frame (12) with the **Retract tracks/counterweight** button on the remote control. The counterweight is now hanging freely.
12. Lower the counterweight by retracting the boom (remote control lever 2 backward). Make sure the counterweight remains clear of the crane and the outriggers. Make sure the bow shackle on the counterweight removal cable at the rear of the boom does not go over the sheave.
13. Remove the counterweight removal cable and install the rear cover of the boom.
14. Store the counterweight retainer with the corresponding bolts and the counterweight removal cable with bow shackle and the tools in a safe place, such as the crane's toolbox.
15. The crane can now be positioned in the transport mode and driven away from the counterweight.

Inspection

16. Check whether the counterweight has disappeared from the display on the remote control.
17. Check whether the counterweight is in a safe position, move the counterweight if necessary and/or cordon off the area around the counterweight to prevent accidents.

5.12.2 Removing counterweight with external equipment

Preparation

- Arrange for lifting equipment with sufficient capacity and the appropriate lifting accessories.
- Make sure the crane is supported on the outriggers in a square configuration, with the crawler tracks just above the ground and no load on the hook.
- Make sure the boom is horizontal or in the transport position.

Required tools

- 10 mm hex key or ratchet spanner
- 24 mm combination spanner or ratchet spanner

Execution

1. Extend the counterweight with the **Extend tracks/counterweight** button on the remote control. Switch off the control for the crane.
2. Position the lifting device under or attach it to the counterweight and allow it to bear part of the weight of the counterweight. The counterweight support is not suitable for horizontal transport of the counterweight. To do this, use a two-leg sling that is hooked directly to the outrigger pad holders on top of the counterweight.
3. Take off the counterweight retainer by removing the two hex head bolts with a 24 mm spanner.
4. Lift with the lifting device until it is supporting the entire counterweight weight.
5. Switch on the crane's control and retract the counterweight frame with the **Retract tracks/counterweight** button on the remote control.
6. Remove the counterweight with the lifting device and put it in a safe place.
7. Store the counterweight retainer with the corresponding bolts in a safe place, such as the toolbox.

Inspection

8. Check whether the counterweight has disappeared from the display on the remote control.
9. Check whether the counterweight is in a safe position and cordon off the area around the counterweight to prevent accidents.

5.12.3 Fitting counterweight with your own equipment

Preparation

- Position the crane with retracted crawler tracks as close as possible to the counterweight so the counterweight is located with the counterweight support on the left side, beside the crane's turntable.
- Make sure the crane is supported on the outriggers in a square configuration, with the crawler tracks just above the ground and no load on the hook.
- Make sure the boom is horizontal.

Required tools

- 10 mm hex key or ratchet spanner
- 24 mm combination spanner or ratchet spanner

Execution

1. Extend the outriggers and position the boom at right angles to the crane with the counterweight on the left or right side of the crane.
2. Take the counterweight support out of the storage position and mount and secure it in the counterweight removal position.
3. Remove the rear cover of the boom with a 10 mm hex key.
4. Extend the boom slightly (remote control lever 2 forward) and switch the control off.
5. Attach the counterweight removal cable to the back of the outermost sliding boom section with a bow shackle.
6. Attach the other end of the counterweight removal cable to the counterweight removal support with the lynch pin. Make sure the cable is not twisted and does not have any loops/windings.
7. Switch the control on and slide the boom out until the counterweight is at the correct height to slide the counterweight support beneath it. Make sure the counterweight cable is guided over the cable sheave correctly. During extension, pay attention to the front of the boom too.
8. Rotate the counterweight a quarter turn.
9. Slide out the counterweight frame and position the counterweight on the counterweight frame, then lower the counterweight while keeping the cable under tension. Make sure the counterweight is straight, to prevent damage to the sensors.
10. Fit the counterweight retainer and tighten the two bolts with a 24 mm spanner.
11. Check whether the counterweight appears on the display of the remote control. If not, check whether the counterweight is positioned parallel to the counterweight frame. Reposition if necessary.
12. Release tension on the counterweight removal cable by sliding the boom in. Make sure the bow

shackle on the counterweight cable does not go over the cable sheave.

13. Remove the counterweight removal cable and install the rear cover of the boom.
14. Take the counterweight removal support out of the counterweight and mount and secure it in the storage position.
15. The crane can now be put in the transport position.

Inspection

16. Check whether the counterweight is visible on the display of the remote control, both in the extended and retracted positions.
17. Check that the loose parts have been put away or are attached.

6.

TROUBLESHOOTING

6.1 Warnings pertaining to malfunctions

Correct operation and careful maintenance will extend the life of the crane and ensure many years of trouble-free operation.

The following warnings must be observed for all work performed in connection with a malfunction.

**DANGER**

Remove key from key switch when performing work on the electrical system and prevent unauthorised people from switching on the crane

**DANGER**

Never use your hand to locate a leak in the hydraulic system; use a piece of paper or cardboard instead. Oil under high pressure can penetrate the skin and cause poisoning.

**WARNING**

Hydraulic oil can be hot; wear gloves and safety glasses when troubleshooting the hydraulic system.

**WARNING**

Repair leaks in the hydraulic system immediately and top up the oil reservoir.

**WARNING**

Before disconnecting hydraulic lines and hoses, precautionary measures must be taken to ensure that the line/hose is no longer under pressure once the supply of energy to the system has been switched off. This can be achieved by moving the control levers back and forth.

**WARNING**

If you are unable to correct a malfunction, contact your dealer or Hoeflon International B.V.

6.2 Troubleshooting

A number of possible malfunctions are described hereafter. If a malfunction occurs that is not listed in this user manual, contact your dealer or Hoeflon International B.V.

Fault	Cause	Solution
The crane is not working properly; it jerks.	Too little oil in the hydraulic system	Check the hydraulic oil level.
	Hesitation when operating toggle on remote control	
Vibrations in the crane	Oil temperature too low	Increase the oil temperature by raising and lowering the boom.
Telescopic section does not extend or retract fully or does not do so easily	Guides not sufficiently lubricated	Lubricate the guides
The crane does not slew well	Turntable not sufficiently lubricated	Lubricate the turntable
	Damaged or worn rotation mechanism	Overhaul rotation mechanism
A number of functions do not work	Problem in electrical system	Check sensors
		Check emergency stop buttons
		Reduce the load on the crane
Movements are slower than usual	Oil filter restricted	Clean oil filter
	Hydraulic pump defective	Replace hydraulic pump
Crunching sound during movements	Pivot points not sufficiently lubricated	Lubricate pivot points in accordance with the lubrication chart

6.3 Fault codes

The following table shows the fault codes that may appear on the display. If the suggested solution does not work, contact your dealer or Hoeflon International B.V.

If the problem is in the software (E001 – E010) or there is a problem with the connection (E59 – E75), please also contact Hoeflon International B.V.

Code	Problem	Possible solution
E028	Crane is not supported properly by outriggers	Set outriggers again.
E078	No contact with left-front angle sensor	Switch off the crane and switch it on again.
E079	Incorrect value left-front angle sensor	Switch off the crane and switch it on again.
E080	Incorrect value left-front angle sensor	Switch off the crane and switch it on again.
E081	Problem left front	Contact Hoeflon International B.V. or your dealer.
E082	Problem left-front length sensor	Activate the bypass and extend farther. The fault code disappears. Switch the bypass off.
E083	Problem left-front length sensor	Activate the bypass and extend farther. The fault code disappears. Switch the bypass off.
E085	No contact with right-front angle sensor	Switch off the crane and switch it on again.
E086	Incorrect value right-front angle sensor	Switch off the crane and switch it on again.
E087	Incorrect value right-front angle sensor	Switch off the crane and switch it on again.
E088	Problem right front	Contact Hoeflon International B.V. or your dealer.
E089	Problem right-front length sensor	Activate the bypass and extend farther. The fault code disappears. Switch the bypass off.
E090	Problem right-front length sensor	Activate the bypass and extend farther. The fault code disappears. Switch the bypass off.
E092	No contact with right-rear angle sensor	Switch off the crane and switch it on again.
E093	Incorrect value right-rear angle sensor	Switch off the crane and switch it on again.
E094	Incorrect value right-rear angle sensor	Switch off the crane and switch it on again.
E095	Problem right front	Contact Hoeflon International B.V. or your dealer.
E096	Problem right-rear length sensor	Activate the bypass and extend farther. The fault code disappears. Switch the bypass off.
E097	Problem right-rear length sensor	Activate the bypass and extend farther. The fault code disappears. Switch the bypass off.
E099	No contact with left-rear angle sensor	Switch off the crane and switch it on again.
E100	Incorrect value left-rear angle sensor	Switch off the crane and switch it on again.

Code	Problem	Possible solution
E101	Incorrect value left-rear angle sensor	Switch off the crane and switch it on again.
E102	Problem right front	Contact Hoeflon International B.V. or your dealer.
E103	Problem left-rear length sensor	Activate the bypass and extend farther. The fault code disappears. Switch the bypass off.
E104	Problem left-rear length sensor	Activate the bypass and extend farther. The fault code disappears. Switch the bypass off.
E106	No contact with jib angle sensor	Switch off the crane and switch it on again.
E107	Incorrect value jib angle sensor	Switch off the crane and switch it on again.
E108	Incorrect value jib length sensor	Activate the bypass and extend farther. The fault code disappears. Switch the bypass off.
E110	No contact with boom angle sensor	Switch off the crane and switch it on again.
E111	Incorrect value boom angle sensor	Switch off the crane and switch it on again.
E113	No contact with pressure sensor boom lift cylinder	Switch off the crane and switch it on again.
E114	No contact with pressure sensor boom lift cylinder	Switch off the crane and switch it on again.
E116	No contact with bin angle sensor	Switch off the crane and switch it on again.
E117	Incorrect value bin angle sensor	Switch off the crane and switch it on again.
E118	Incorrect value bin dummy sensor	Check placement of dummy.
E120	No contact with boom rotation sensor	Switch off the crane and switch it on again.
E121	Incorrect value boom rotation sensor	Switch off the crane and switch it on again.
E122	Incorrect value boom rotation sensor	Switch off the crane and switch it on again.
E126	Alternator not charging	Check alternator.
E131	Counterweight is crooked	Extend/retract counterweight.
E132	Counterweight is crooked	Extend/retract counterweight.
E133	Counterweight is crooked	Extend/retract counterweight.
E135	Winch oil pressure not good	Contact Hoeflon International B.V. or your dealer.
E136	No contact with pressure sensor	Switch off the crane and switch it on again.
E137	Incorrect value of pressure sensor	Switch off the crane and switch it on again.
E138	Pressure too high	Wind out lifting cable, reduce lifting weight.
E139	Fault in winch switch	Lifting cable can only be wound out.
E140	Fault in winch switch	Lifting cable can only be wound in.
E148	No contact with level sensor	Switch off the crane and switch it on again.
E149	Invalid value level sensor	Switch off the crane and switch it on again.
E142	Maintenance (minor service)	Contact Hoeflon International B.V. or your dealer.
E153	Maintenance (major service)	Contact Hoeflon International B.V. or your dealer.
E154	Maintenance	Contact Hoeflon International B.V. or your dealer.
W171	Malfunction main pressure sensor	Contact Hoeflon International B.V. or your dealer.
E172	Malfunction electric motor	Contact Hoeflon International B.V. or your dealer.
E173	Malfunction battery pack	Contact Hoeflon International B.V. or your dealer.

7.

TRANSPORT, STORAGE AND DISPOSAL

7.1 Transport

**WARNING**

Only use suitable lifting accessories with the correct capacity for the lifting application. The lifting accessories must be accompanied by a certificate, have a periodic inspection, be visually inspected and have been found to be suitable for use.

**WARNING**

The clearance angle of the loading ramps must not exceed 15°.

**WARNING**

When transporting the crane, make sure the crane is in transport mode and that any load is removed: No load on the hook, outriggers stowed in transport position and boom retracted.

**WARNING**

Never use the emergency stop button to switch off the crane during normal operation.

**WARNING**

Make sure when driving up a slope (e.g. via the lifting plate on a transport device) that the piston legs on the lowest edge are folded over to prevent the crane from tipping over. This also applies when the crane is driven down.

Please note the following points:

- Make sure the outriggers are fully retracted and locked in position and that the crane is fully collapsed.
- There must not be any load on the crane.

- Use loading ramps of sufficient size and capacity. The loading ramps must be long enough so that the angle with the ground is less than 15°.
- Drive the crane forward, onto a suitable transport vehicle. When driving up the ramps the operator must be assisted by a person who provides instructions concerning the driving direction.
- Stop the crane as described in section 'Starting and switching off the crane'.
- Set the main switch on the electrical cabinet to position 0.
- Remove any loose parts from the crane.
- Make sure that the outriggers are fully retracted and locked in position and that the crane is fully collapsed.
- There must not be any load on the crane.

7.1.1 Putting the crane in transport position

The most compact position of the crane is the transport position. That is without jib and with the boom in the lowest position. The outriggers are stowed and the counterweight is retracted. Use this position, with minimum height, for transport and storage of the crane.

With the jib mounted under the boom, the boom is at approximately 1° and the winch will be the highest point of the machine. This is the position that is usually used when moving the crane around the job site.

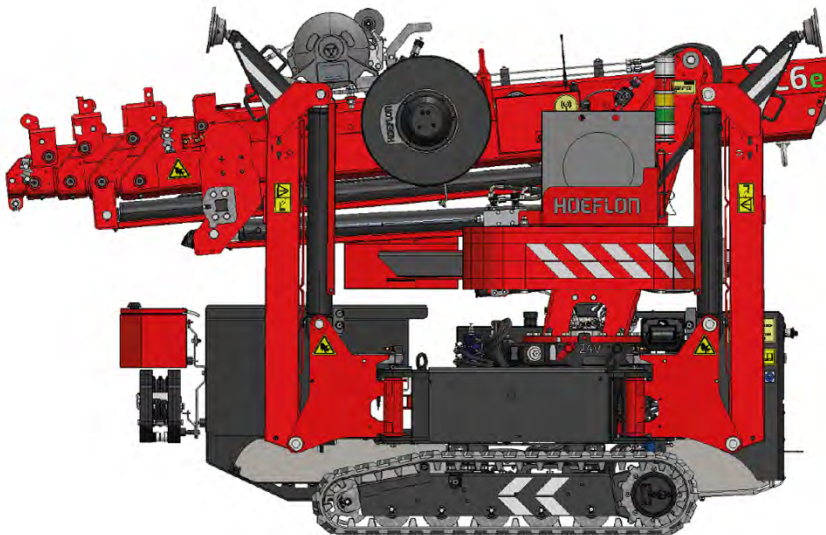

Figuur 7.1 Crane in transport position

Put the crane in the transport position as follows:

1. Slew the crane column so that the white marks are slightly out of alignment (see *Figuur 7.2*). This is necessary to prevent the boom with the attachments from coming into contact with the sensors of the left-front outrigger.
2. When the boom is fully boomed down, slew the crane column back to its original position as shown in

the figure.

3. The jib adapter can be attached to the jib if the jib is hanging beside the boom and other attachments are needed.
4. Attachments must be removed from the crane during transport and secured and locked in the appropriate positions. Some of these attachments and their positions are: adjustable section and winch head alongside the boom, manual jib extension on the counterweight, jib adapter in the boom.
5. The lifting cable must always be wound up.



Figuur 7.2 Centre position of crane column

7.1.2 Securing crane for transport



WARNING

Overloaded lashing eyes can cause damage to the crane. Therefore always heed the following instructions.



WARNING

Folding a lashing strap double also doubles the applied tension.

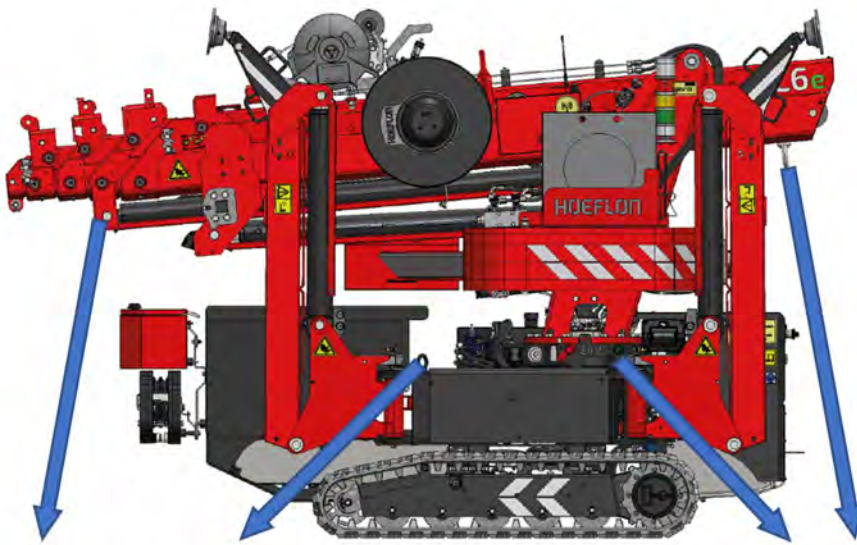

Figuur 7.3 Securing crane

Please note the following points:

Point	Load on attachment point
Lashing points on undercarriage	Max 2500 kg per eye
Lashing points on upper part	Front end max 1500 kg per eye Rear end max 2500 kg per eye

- Towards the front and sides lash down at least 0.5 x the crane's weight; towards the rear lash down at least 1 x the crane's weight.
- It is recommended that the space between the headboard of the transport vehicle and the front of both crawler tracks be filled, in connection with braking forces. Otherwise, use lashing provisions that can hold at least 1.5 x the crane's weight at the rear.
- If the lashing eyes on the undercarriage are used to secure the crane, the upper part must be secured to prevent rotation in both directions. Otherwise the turntable may be damaged by movement that occurs during transport.

- Make sure the crawler tracks of the crane are resting directly on the deck of the transport vehicle, because ground protection plates or anything similar in between will reduce the sliding resistance of the crane relative to the transport vehicle.
- Secure the machine by attaching four lashing straps to the holes in the outrigger hinge plates. The crane can likewise be secured in the crane column (see *Figuur 7.3*).

7.1.3 Lifting crane for transport

Please note the following points:

1. Lift the crane using lifting straps or chain slings with a capacity of at least 3000 kg. Fasten these to the lifting point on the boom (see *Figuur 7.4*).
2. Make sure the crane is in the transport position.



Figuur 7.4 Lifting point

7.2 Storing the crane



WARNING

If the crane will be placed in storage for more than six months, contact Hoeflon International B.V. for the procedure to be followed.

Perform the following procedure before storing the crane for longer than three months:

1. Remove any dirt and clean the crane with water and, for example, car wash shampoo. You may clean the track undercarriage with a pressure washer.
2. Grease the crane in accordance with the lubrication chart.
3. Repair damage to the paintwork.
4. Grease the parts that may rust.
5. Place the crane in a dry location, protected from rain, heat and cold.
6. Make sure the crane cannot be activated by unauthorised people.
7. Cover the crane with tarpaulin; keep a section free from the ground to allow for ventilation.

Batteries

Instructions for the batteries during storage of the crane:

- less than one week: no actions required.
- one week to one month: connect the charger of the crane.
- longer than one month: ensure that the SOC of the battery pack is between 40% and 70%, then turn off the earth switch. The earth switch (2) can be reached by removing the motor shroud (1) (see *Figuur 7.5*).

After a month or more of disuse, it is important to fully charge the crane before it is used again.

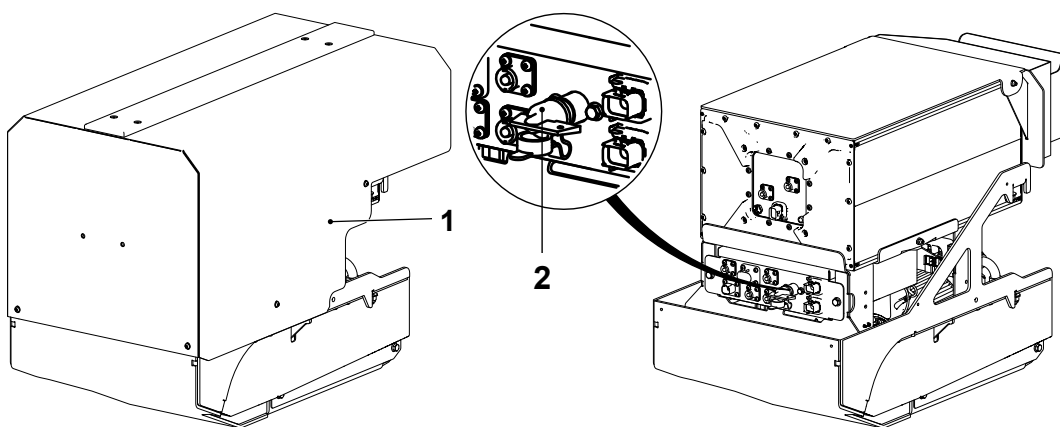

Figuur 7.5 Earth switch

7.3 Waste disposal

Dispose of waste in accordance with the applicable local regulations. Incorrect disposal of waste can be harmful to the environment. Environmentally harmful waste includes: engine oil, diesel fuel, hydraulic oil, differential oil, coolant, filters, batteries and greases.

8.

ANNEXES

8.1 C4e load diagram

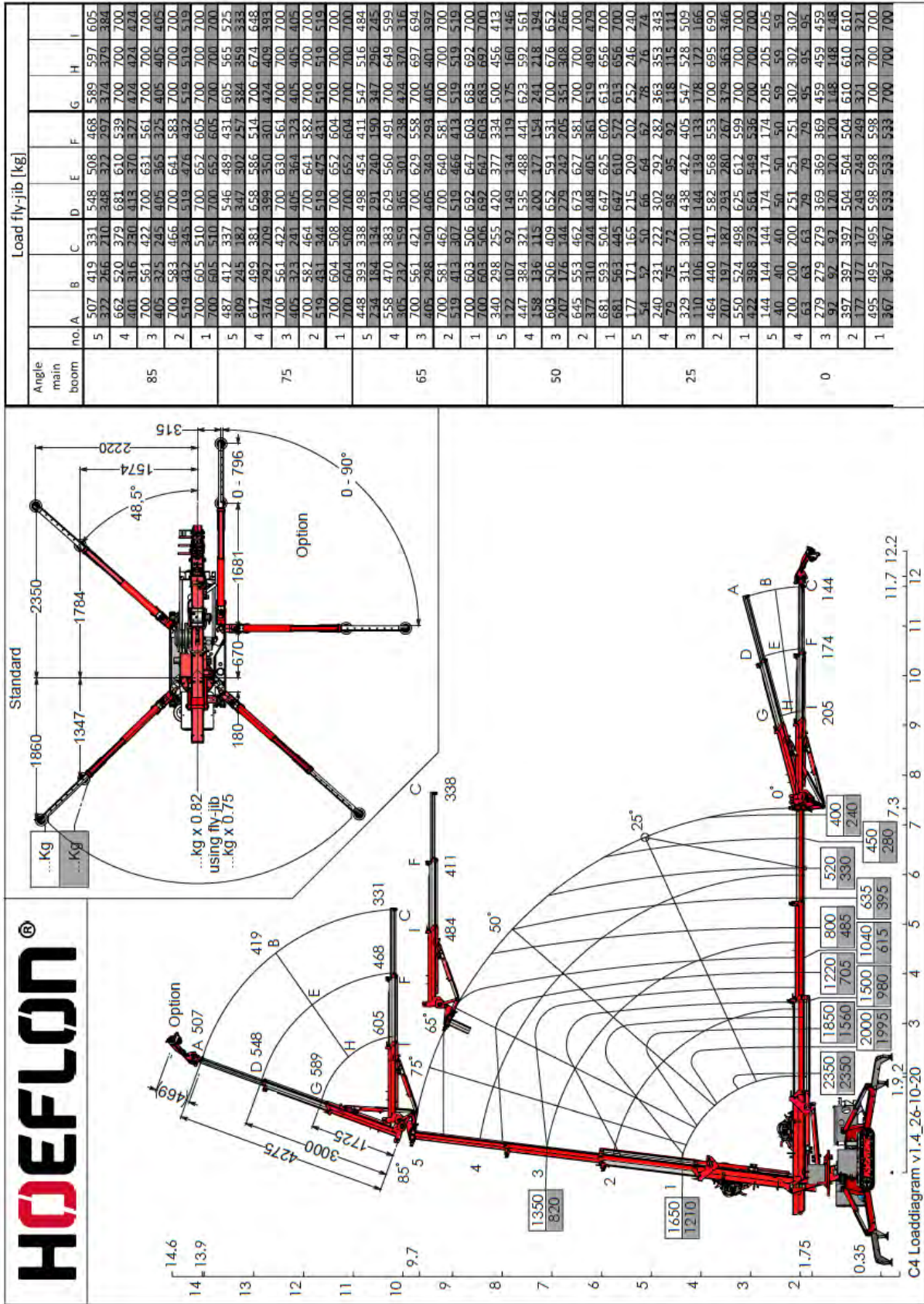

8.2 C6e load chart

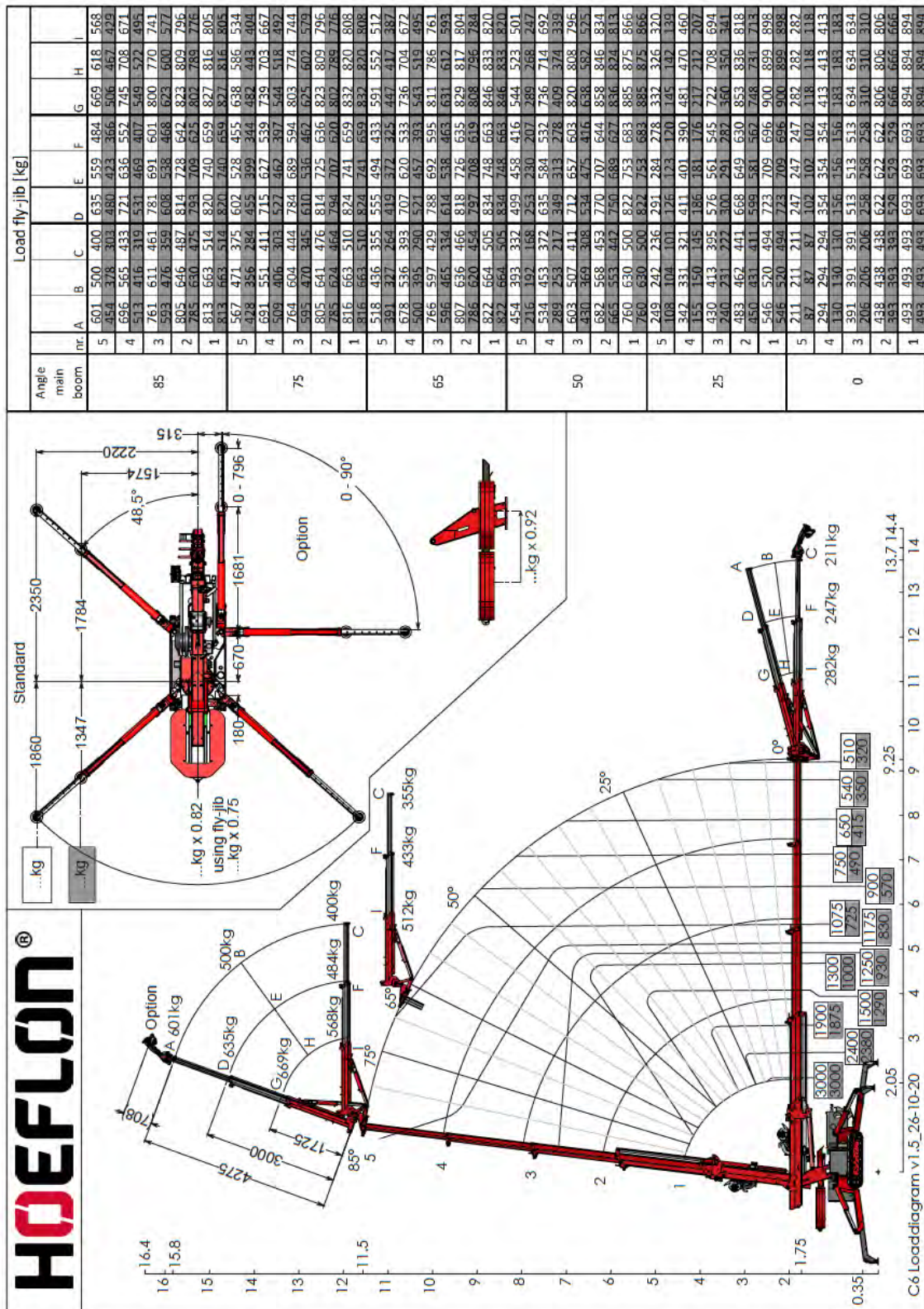

8.3 Maximum outrigger pressure

Maximum outrigger pressure of the C4e - C6e Compact crane.

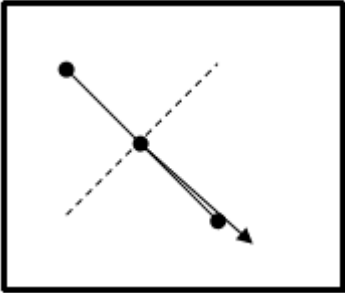
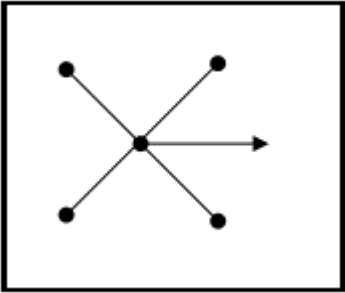
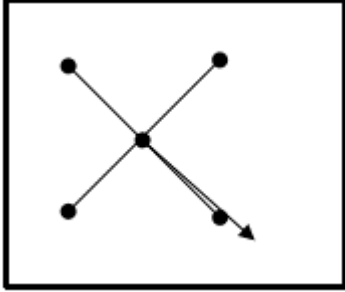
Crane type	C4e	C6e
Outrigger radius	2400 mm	2400 mm
Outrigger angle	4 x 48.5°	4 x 48.5°
Outrigger length	Extended	Extended
Counterweight weight	Extended	Extended
Maximum lifting capacity	2350 kg	3000 kg
Net weight	2000 kg	2850 kg
Maximum outrigger pressure in the most unfavourable position 	2450 kg	3300 kg
Minimum outrigger pressure 	1600 kg	2150 kg
Maximum outrigger pressure with outriggers in square configuration 	1900 kg	2600 kg