

HOEFLON®

User manual

Glass suction lifter C600



Serial number:

Delivery date:

Reference: U.C600.01.00.EN

Version: 1.0

Translation of the original manual

VERSION HISTORY

Version	Date of Issue	Remark	From serial number
1.0	01-01-2020	First edition	250 XXXX

Manufacturer

Grip Lifting Equipment
Handelsweg 1 C
2861 GN Bergambacht, The Netherlands

T: +31(0)85 018 0321
I: www.grip-lifting.nl
E: info@grip-lifting.com

INTELLECTUAL PROPERTY RIGHTS

All rights reserved.

No part of this publication may be reproduced, stored in a retrieval system, or transmitted in any form or by any means (electronically or mechanically, including photocopying, recording or otherwise) without the prior written permission of Hoeflon International B.V. This also applies to the accompanying drawings and charts.

© Copyright 2020 Hoeflon

TABLE OF CONTENTS

VERSION MANAGEMENT	2
INTELLECTUAL PROPERTY RIGHTS	2
TABLE OF CONTENTS	3
1. INTRODUCTION	5
1.1 Usage of this manual	5
1.2 Marking conventions	6
1.3 Marking & indication	6
1.4 Warranty	7
1.5 Compliance	7
1.6 Nameplate	8
2. GENERAL SAFETY	9
3. INTENDED USE	10
4. TECHNICAL SPECIFICATIONS	11
4.1 Noise level	12
4.2 Transport & storage	12
5. SAFETY FEATURES	13
5.1 General	13
5.2 Shielding of electrical parts	13
5.3 Switching the machine on and off	13
5.4 Audible alarm	14
5.5 Personal protective equipment	14
5.6 Residual risks	14
5.7 Ergonomics	14
6. USAGE	15
6.1 General	15
6.2 Starting conditions	16
6.3 Controls and indicators	17
6.4 Operating instructions	18
6.4.1 Switching the machine on	18
6.4.2 Positioning on the load	18
6.4.3 Applying the lifter to the load (Machine Controls)	18
6.4.4 Applying the lifter to the load (Remote Control)	18

6.4.5	Tilting of the load _____	19
6.4.6	Rotating of the load _____	19
6.4.7	Releasing the lifter from the load (Machine Controls) _____	19
6.4.8	Releasing the lifter from the load (Remote Control) _____	20
6.4.9	Secure load in case of alarm _____	20
6.5	Requirements during use _____	21
6.6	Requirements after use _____	21
7.	MAINTENANCE & INSPECTION _____	22
7.1	General _____	22
7.2	Maintenance and inspection tasks _____	23
7.2.1	Explanation of suction cup inspection _____	24
7.2.2	Explanation of Controls & Indicators inspection _____	24
7.2.3	Explanation of Voltage Gauge inspection _____	24
7.2.4	Explanation of Pressure Gauge inspection _____	24
7.2.5	Explanation of Vacuum System inspection _____	24
7.2.6	Explanation of Machine Frame inspection _____	24
8.	TROUBLESHOOTING _____	25
8.1	Instructions for replacing the battery _____	26
9.	DISASSEMBLY & DISPOSAL _____	27
10.	APPENDIX 1: DECLARATION OF CONFORMITY _____	28

1

INTRODUCTION

This manual describes the Glass-Maxx C600 as manufactured by Grip Lifting Equipment, based in Bergamacht, the Netherlands. The information in this manual is important for the correct and safe usage of the machine.

This manual is a translation off the original user manual, created by Grip Lifting Equipment in the Dutch language. In case of any ambiguities and/or disputes, the text from the original Dutch user manual always prevails.

If you are not familiar with the commissioning, operation, and maintenance of the machine, please read this user manual carefully from start to finish.

If you are familiar with these matters, you can use this user manual as a reference. You can quickly find the information you need using the table of contents.

In this user manual the words machine, vacuum lifter and C600 are used interchangeably. These terms always refer to the Glass-Maxx C600.

1.1 Usage of this manual

This user manual is written for authorized persons and technically skilled persons. All parties involved must take note of the contents of this manual. These persons are distinguished as follows:

Authorized persons are persons who:

Have built up a certain level of knowledge through education or training and who have sufficient experience to work with the machine.

Technically competent persons are persons who:

Are qualified as an authorized person and who have a medium technical knowledge level, through education and / or work experience. Furthermore, these persons have a decent knowledge of machine techniques, making them well aware of the possible dangers and risks.





By working with the machine, we mean:

Starting and stopping the machine, cleaning, and performing simple maintenance work.



The purpose of this user manual is to create a safe and efficient interaction between the operator and the machine.

1.2 Marking conventions





Marking conventions are indications in the user manual and are not applied to the machine itself. The following marking conventions are used to alert the user to certain actions or hazardous situations:

	NOTE	Suggestions and advice to make certain tasks easier or more convenient.
	ATTENTION	Note with additional information; alerts to possible problems.
	CAUTION	The machine can be damaged if you do not follow the procedures carefully.
	DANGER	You can be seriously injured if you do not perform the procedures carefully.

1.3 Marking & indication

	ATTENTION	Regularly check whether all indications are still present and legible; if not, replace it.
	DANGER	Respect and follow the indications, these are applied for YOUR SAFETY.

A number of symbols have been applied to the machine, with the purpose of warning users of residual risks that may remain despite the safety measures taken. The table below gives an overview of the symbols used.

Symbol	Description	Location
	Prohibited: Forbidden to go under a suspended load.	Bottom left on the machine
	Warning: Risk of trapping/crushing the hands	Hanging on the machine
	Information: Read and follow the User Manual	Bottom left on the machine
	CE marking: Indicates conformity with European directives	Nameplate

1.4 Warranty

The warranty conditions and the provisions with regard to liability can be found in the terms of delivery.

1.5 Compliance

The machine complies with the applicable European Directives. A number of standards have been applied during the design to meet the basic requirements of the directives.

Based on this, the CE marking is applied to the nameplate (see figure 1)

The guidelines and standards are stated on the Declaration of Conformity (see appendix 1)

1.6 Nameplate

The machine is provided with the nameplate below (see figure 1).

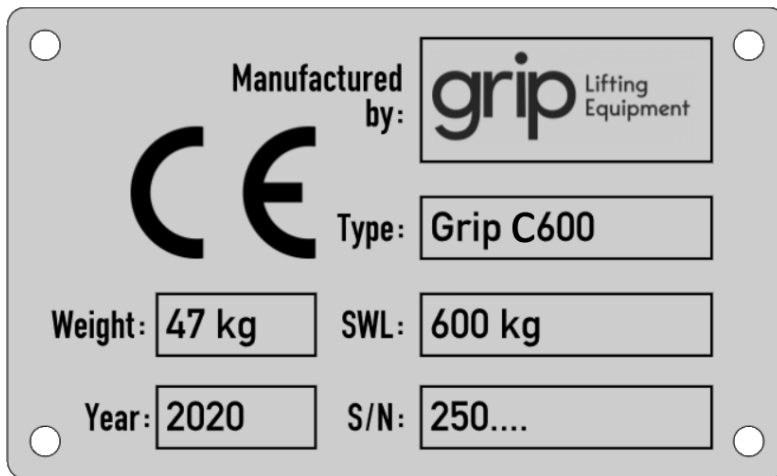

Figure 1: Nameplate

2

GENERAL SAFETY

- Safety is important! Everyone is responsible for a safe workplace. Report dangers and / or dangerous situations to your supervisor immediately.
- The work environment in which the machine is used must comply with local health- and safety legislation.
- The operator / owner is responsible for a clean and well-lit work environment in which the machine can be used safely.
- Read this user manual carefully before first use. The manufacturer is not liable for injuries, damage and / or excessive wear resulting from improper use, maintenance, or modifications to the machine.
- Under all circumstances, the operator is responsible for the correct interpretation and application of this manual. If in doubt, contact the manufacturer.
- This manual must be easily accessible to all users.
- The manufacturer recommends that operators and maintenance personnel be trained in the operation and maintenance of the machine.
- The machine may not be modified without the prior written permission of the manufacturer.
- Changing settings or using unauthorized / original spare parts or repair methods releases the manufacturer from any liability.
- Do not exceed the machine safe working load (SWL).
- Before using the machine, check that it has been periodically inspected. Using a hoisting / lifting device that has not been inspected (on time) is strictly forbidden.
- Comply with local work instructions and safety regulations.
- The owner and / or operator of the machine is responsible for complying with the regulations stated in this manual.
- It is forbidden to use the machine in a potentially explosive atmosphere.

3

INTENDED USE

The intended use of the machine means the use for which the machine is specifically designed and built. The intended use can be described as follows:

The Glass-Maxx C600 is a vacuum lifter for placing and moving flat and non-porous glass panels of medium to large sizes. The load must be rigid so that it does not bend excessively.

Any use other than the intended use mentioned above may cause damage to the machine and danger to persons in the vicinity. Any use other than the intended use excludes the manufacturer from any responsibility and liability.

4

TECHNICAL SPECIFICATIONS

General	
Machine dimensions (L x W x H) [mm]	840 x 480 x 190
Machine weight [kg]	29
Net lifting capacity Single-Circuit	600
Net lifting capacity Dual-Circuit	300
Rotational range	360 (4 locking positions)
Tilting range	90 (6 locking positions)
Technical life span	10 years

Electrical system	
Power source	Battery
Voltage [VDC]	12
Current [Ah]	9

Vacuum system	
Req. vacuum pressure	0.60 bar

Working Environment *	
Min. Temperature:	0
Max. Temperature:	45
Max. Wind Speed	10
Max. Working Height	1.000 m (above sea-level)
* Contact Grip Lifting Equipment or your supplier to discuss work exceeding the working environment limits.	

4.1 Noise level

The noise level is measured in accordance with the Machinery Directive. The equivalent continuous A-weighted sound pressure is measured in the workplace during normal working conditions. The measurement was taken at a distance of 1 meter from the machine at a height of 1.60 meters above the work floor. The level of the equivalent continuous A-weighted sound pressure is less than 65 dB (A) during operation.

4.2 Transport & storage

	CAUTION	Transporting and handling of the machine must be done carefully to avoid damage or malfunctions
---	----------------	---

During the design of the machine, the efficient moving and lifting of the machine has been taken into account. Always use approved hoisting and lifting equipment for transport and use it according to the manufacturer's instructions.

The machine must be stored under the following conditions:

- Store the machine in the supplied storage trolley or storage trolley or storage box after each use.
- The sealing profile of the suction cup must be free from the surface to prevent permanent deformation.
- Store the lifter in a dry environment.
- The minimum ambient storage temperature is 0°C
- The maximum ambient storage temperature is 40°C
- Do not store the machine in direct sunlight or rain for a long time.
- Charge the battery after each use or monthly if the machine will not be used for an extended period of time.

5

SAFETY FEATURES

5.1 General

After determining the hazards present and assessing the risks, the following safety measures have been taken to eliminate or at least minimize the hazards.

5.2 Shielding of electrical parts



DANGER

Safety features must never be removed, bridged, or otherwise deactivated.

The internal components of the machine are shielded with two covers. Do NOT use the lifter while the covers are removed. This prevents the risk of damage to the machine.

5.3 Switching the machine on and off

The supply voltage can be switched off by means of the on / off switch on the machine. To carry out maintenance work, disconnect the battery after the machine has been switched off.



Figure 2: on / off switch

5.4 Audible alarm



DANGER

The audible alarm warns of an insufficient vacuum pressure level during machine operation.

The audible alarm warns the user if at least one of the two systems has an insufficient vacuum pressure. If the alarm sounds while lifting, put the load down immediately and safely.

5.5 Personal protective equipment

The manufacturer recommends wearing at least the following PPE when working with the machine: safety helmet, safety shoes and work gloves.

In addition, follow the local safety regulations regarding personal protective equipment.

5.6 Residual risks



DANGER

It is forbidden to hang on to an attached machine while it is being lifted.



DANGER

The machine should not be used when it is connected to the charger



DANGER

Tilting the lifting arm poses a risk of crushing the fingers or hand.

5.7 Ergonomics

During the design phase, careful attention was paid to ergonomic aspects. The machine is designed and constructed in such a way that maximum account is taken of human ergonomic aspects.

6

USAGE

6.1 General

	DANGER	The machine may only be operated by persons at least the qualification as Authorized. (see § 1.1 Usage of this manual).
	DANGER	Do not use the machine if damage or defects are observed or are suspected.
	DANGER	Do not use the machine in an environment with a sound level higher than 70 db.
	DANGER	Wear the personal protective equipment common within the organization / environment in which the machine is used.
	DANGER	Before starting work, always check that there are no persons in the drop zone of the load.
	DANGER	Pay attention to your stance during operation. Make sure you are standing firmly and try not to reach too far.
	DANGER	Never lift a load above yourself or other persons. This is strictly prohibited!

**CAUTION**

Operators must be older than 18 years and must not be under the influence of alcohol, narcotics, or medications.

**ATTENTION**

It is only allowed to perform tasks for which training has been received. This applies to both maintenance and operation tasks.

6.2 Starting conditions

Before priming the machine, perform the following actions:

1. Check the surface of the suction cups, they must be clean and dry.
 - If necessary, clean the surface with cleaning vinegar and then dry it thoroughly and completely.
2. Check the surface of the load, it must be clean and dry
 - If necessary, clean the surface of the load with water and then dry it thoroughly and completely.
3. Check the voltage on the voltmeter
 - Do not use the machine if the voltage is less than 12V while stationary, or less than 10V while the pump is running. If the voltage is lower than mentioned above, charge or change the battery before resuming work.

Before lifting the machine and load, perform the following actions:

1. Check the pressure on the vacuum gauges
 - Do NOT use the lifter while the pointer of one or both of pressure gauges is in the RED area.
2. Check that the machine is switched on and the green LED is lit.
 - When the machine is switched off while primed to a load, none of the safety features and alarms work.
3. Check the positioning of the machine on the load
 - See § 6.4 Operating instructions
4. Check that all locking pins are present and in fully locked position.

6.3 Controls and indicators

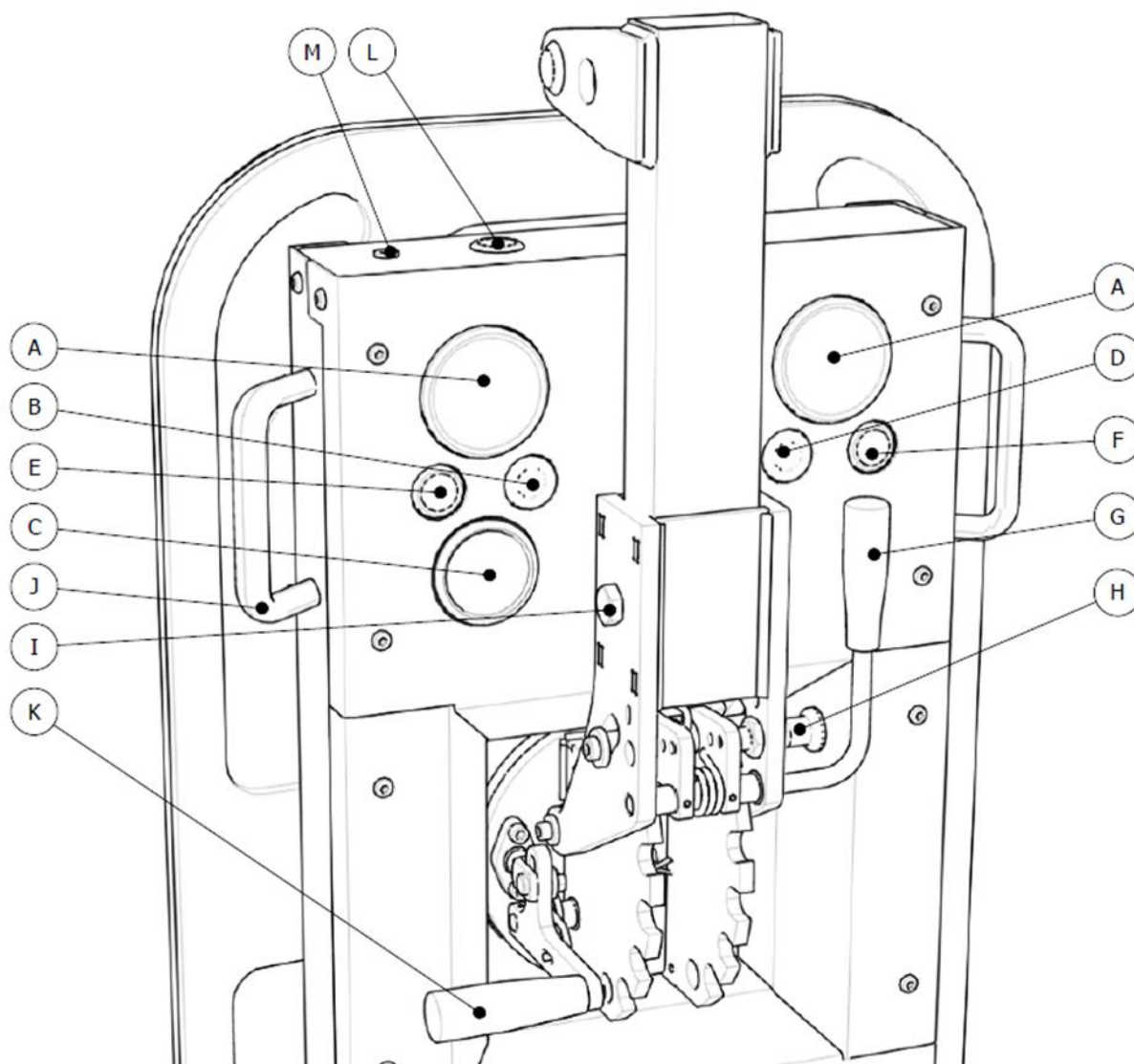

- A: Vacuum Gauge
- B: Green LED
- C: Voltage Gauge
- D: Red LED
- E: Push Button 1
- F: Push Button 2
- G: Tilt Release Lever
- H: Tilt Release Lever Lock
- I: Exchangeable Lifting Arm - Locking Pin
- J: Handle
- K: Rotation Release Lever
- L: Power Button
- M: Charging Port

6.4 Operating instructions

6.4.1 Switching the machine on

1. Press the power button to switch the machine on.

6.4.2 Positioning on the load

1. Position the machine in the middle of the width of the load.
2. Position the machine at the center or above the center of the height of the load.

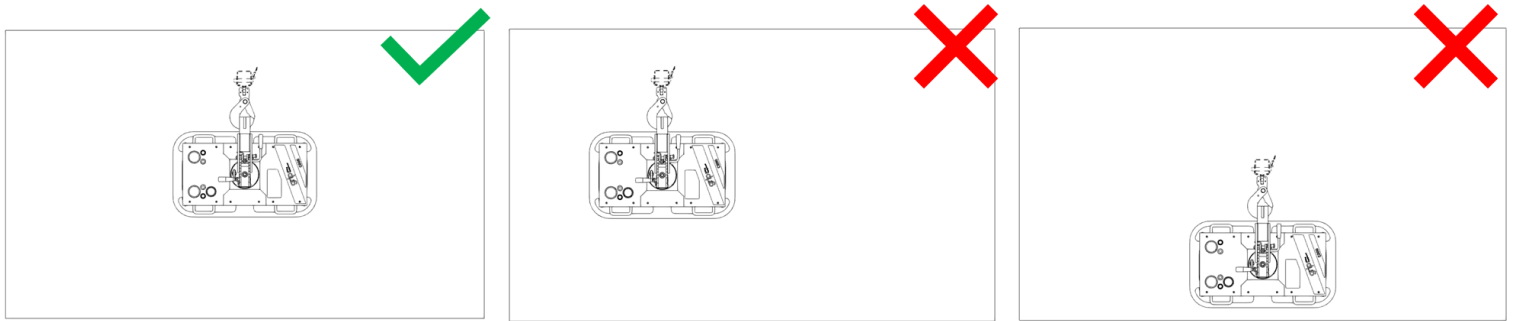

6.4.3 Applying the lifter to the load (Machine Controls)

1. Press the lifter against the load, to close off the sealing edges of the suction pad(s).
2. Press push button 1 [E] on the lifter.
3. Wait until the GREEN LED is active before lifting the load.

6.4.4 Applying the lifter to the load (Remote Control)

1. Press the lifter against the load, to close off the sealing edges of the suction pad(s).
2. Press the center button on the remote control.
3. Wait until the GREEN LED is active before lifting the load.

6.4.5 Tilting of the load



DANGER

The load can experience uncontrolled movement when the tilting lock is unlocked. To prevent this, hold the load firmly or ask for help from a colleague if necessary.

1. Disengage the tilt release lever lock by pulling it outward and rotating it 90 degrees.
2. Pull the tilt release lever [G] back.
3. Tilt the load in the desired position.
4. Push the tilt release lever back in place. Check that the handle is fully pushed back.
5. Re-engage the tilt release lever lock by rotating it 90 degrees and pushing it back in place.

6.4.6 Rotating of the load



DANGER

De last kan bij het ontgrendelen ongecontroleerd bewegen. Houd - om dit te voorkomen - de last stevig vast of vraag hulp aan een collega indien nodig.

1. Pull the tilt release lever [G] back.
2. Rotate the load to the desired position.
3. Push the tilt release lever back in place. Check that the handle is fully pushed back.

6.4.7 Releasing the lifter from the load (Machine Controls)



DANGER

Make sure that the machine hangs tension-free and straight under the lifting point to prevent uncontrolled machine movement

1. Press pushbuttons 1 [E] and 2 [F] simultaneously.

6.4.8 Releasing the lifter from the load (Remote Control)



DANGER

Make sure that the machine hangs tension-free and straight under the lifting point to prevent uncontrolled machine movement.

1. Press the center button on the remote control.
2. Release the center button.
3. Press the left- and right buttons on the remote control simultaneously and keep these pressed for 5 seconds.

6.4.9 Secure load in case of alarm



DANGER

Make sure that the machine hangs tension-free and straight under the lifting point to prevent uncontrolled machine movement.



NOTE

The lifter will hold the load for at least 5 minutes after the alarm sounds.

1. Check the environment and determine a safe location to place the load.
2. Lower the load as close to the ground as possible.
3. Move the load to the location where it can be placed.
4. Release the lifter as described in points 7 and 8.
5. Inspect the machine and resolve any malfunction. If the malfunction cannot be rectified, contact the manufacturer or supplier.

The machine must not be used until the problem / malfunction has been remedied!

6.5 Requirements during use

1. If the alarm sounds while lifting, put the load down immediately and safely.
 - It is forbidden to continue working while the alarm sounds!
2. Stay within sight and earshot from the machine during operation
 - The alarm must be visible and audible at all times.
3. Make sure that the machine hangs tension-free and straight under the lifting point.
 - This prevents uncontrolled machine movement.
4. Always communicate with those present before moving the load or disconnecting the machine
 - This is especially important when using the machine with remote control.

6.6 Requirements after use

1. Store the machine in the supplied storage support after each use.
 - The sealing profile of the suction cup must be free from the surface to prevent permanent deformation.

7

MAINTENANCE & INSPECTION

7.1 General

The machine is maintenance-free for the operator. During the required periodic inspection, the condition of all parts is checked and replaced - if necessary.

However, it is important that the user keeps the machine clean and the checks below are carried out in a timely manner (see maintenance and inspection schedule)

After a repair or replacement performed by the owner / operator, all daily and monthly inspection tasks should be performed.

7.2 Maintenance and inspection tasks

The maintenance instructions below are based on normal operating conditions and ambient temperatures.

When the machine is used intensively or when it is used under extreme conditions, maintenance should be carried out more frequently. In this case, adjust the frequency of the maintenance tasks accordingly in consultation with the manufacturer.

The table below provides an overview of the necessary maintenance and inspection tasks.

Action	Frequency			
	Daily	Monthly	Annually	Every three years
Suction Cup				
Inspect	●			
Clean		●		
Periodic Inspection			●	
Controls & Indicators				
Inspect	●			
Periodic Inspection			●	
Vacuum Pump				
Inspect		●		
Periodic Inspection			●	
Preventive Replacement				●
Vacuum system				
Inspect		●		
Periodic Inspection			●	
Machine Frame				
Inspect	●			
Clean		●		
Periodic Inspection			●	

7.2.1 Explanation of suction cup inspection

1. Check the sealing profile on tears or other types of damage.
2. Check the adhesive joint for damage or excessive wear.

7.2.2 Explanation of Controls & Indicators inspection

1. Switch on the machine. Check that the red LED is lit, and the buzzer sounds immediately after switching on. If the pump starts but the LED or buzzer does not, then these are defective.
2. Check that the green LED switches on before the pump stops. If the pump switches off but the LED does not switch on, it is defective.

7.2.3 Explanation of Voltage Gauge inspection

1. After charging, Switch on the machine. Check that the voltage gauge pointer moves. If the pump starts but the pointer does not move, the voltage meter is defective.

7.2.4 Explanation of Pressure Gauge inspection

1. Switch on the machine and attach it to a load. Check if the pressure gauge pointer moves. If the pump stops and the green LED lights up, but the pointer of the manometer does not move, the manometer is defective.

7.2.5 Explanation of Vacuum System inspection



1. Switch on the machine and attach it to a load. Switch off the machine when the pump stops and write down the pressure shown by both pressure gauges. Check that the vacuum pressure in both systems does not drop more than 0.2 bar within five minutes.

7.2.6 Explanation of Machine Frame inspection

1. Globally check the machine for damage or bent parts. Specifically check the holes of the connecting pins and the connecting pins themselves. If one of the parts shows damage, it must be replaced before the machine can be used again.

8

TROUBLESHOOTING

	DANGER	Check that the supply voltage has been shut off safely before troubleshooting.
	DANGER	Repairs may only be carried out by the manufacturer or authorized dealers.

With the exception of the following actions, repairs may only be carried out by the manufacturer or an authorized dealer. In the event of malfunctions not listed here, contact the manufacturer or your dealer. Do not continue work with the machine until the fault has been corrected.

Malfunction	Possible cause	Solution
Machine does not switch on	Battery is empty or defective Fuse has blown	Charge or replace battery Replace fuse

8.1 Instructions for replacing the battery

- Loosen the four bolts of the cover (see figure 3); remove the cover from the battery compartment.
- Carefully remove the battery from the compartment (see figure 4).
- Transfer the quick-change cable to the new battery.
- Place the new battery in the compartment > check carefully that you are using the correct battery type.
- Replace the cover on the machine and tighten the four bolts securely.
- Perform the daily and monthly inspection tasks according to the inspection schedule in Table 3.



Figure 3



Figure 4

9

DISASSEMBLY & DISPOSAL

When replacing parts or at the end of the machine's service life, the user must ensure that all parts, materials and (liquid) substances are disposed of, destroyed, or reused in accordance with the applicable environmental regulations.

Only common materials are used in the design of the machine. During production, there were accepted waste processing options for this, and no special risks were known when dismantling and disposing of these materials. Most parts of the machine can be recycled.

10

APPENDIX 1: DECLARATION OF CONFORMITY

EG Declaration of Conformity

(In accordance with EC Machinery Directive 2006/42/EC, Annex II, A)

We, Grip Lifting Equipment Handelsweg 1c 2861 GN Bergambacht, The Netherlands Tel: + 31(0)6 2727 1018	Authorized compiler of the technical file: Grip Lifting Equipment Handelsweg 1c 2861 GN Bergambacht, The Netherlands Tel: + 31(0)6 2727 1018
---	--

Declare under our sole responsibility that the following machine:

Type: Glass-Maxx C600	Serial Number:
-----------------------	----------------

Is in conformity with all relevant requirements of the EU Machinery Directive 2006 /42/EC, and those of the following directive(s):

EMC Directive 2014/30/EU

and, where applicable, is in conformity to the following harmonized standard(s) or parts of this standard(s):

- NEN-EN-ISO 14121-2 (2012) Safety of machinery - Risk assessment - Part 2: Practical guidance and examples of methods
- NEN-EN-ISO 12100 (2010) Safety of machinery - General principles for design - Risk assessment and risk reduction
- NEN-IEC 60204-1 (2018) Safety of machinery - Electrical equipment of machines, Part 1: General Requirements
- NEN-EN 614-2:A1 (2008) Safety of machinery - Ergonomic design principles, Part 2: Interactions between the design of machinery and work tasks.

NEN-EN-ISO 14120 (2015)	Safety of machinery - Guards - General requirements for the design and construction of fixed and movable guards
NEN-EN 13849-1 (2016)	Safety of machinery - Safety-related parts of control systems. Part 1: General principles for design
NEN-EN 61000-6-2 (2019)	Electromagnetic compatibility (EMC) - Part 6-2: Generic standards - Immunity for industrial environments
NEN-EN 61000-6-4 (2019)	Electromagnetic compatibility (EMC) - Part 6-4: Generic standards - Emission standard for industrial environments

Signature:

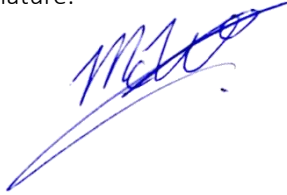

Name: Martijn van Wijngaarden

Position: Owner

City / country: Bergambacht, The Netherlands

Date: 01-05-2020