

# HOEFLON<sup>®</sup>

## USER MANUAL

### Vacuum Lifter VL500

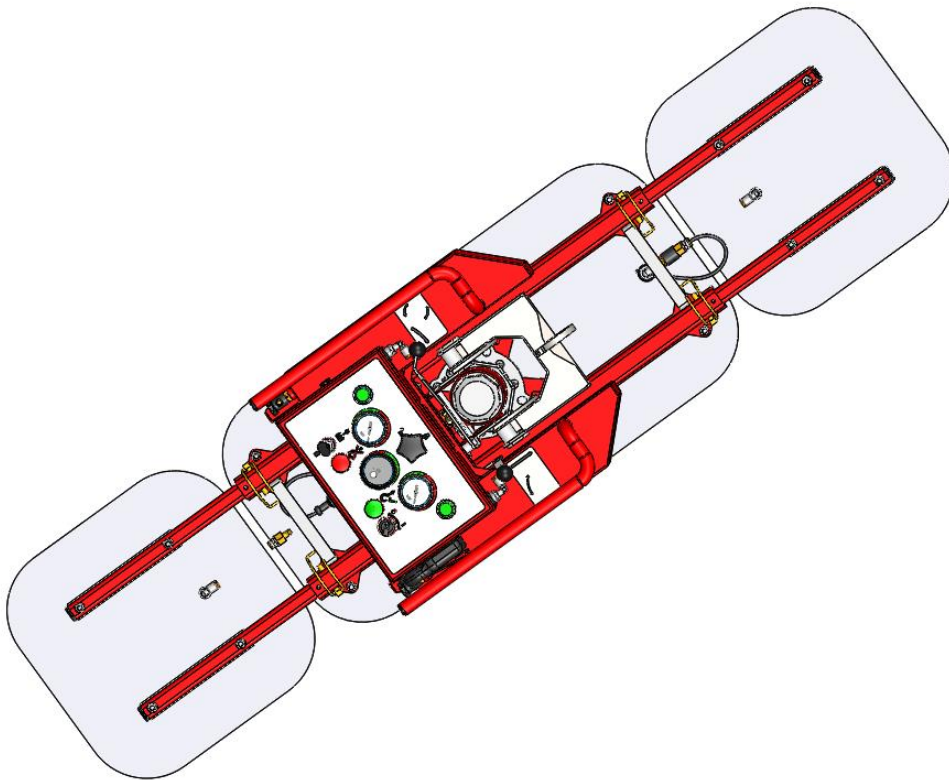

Manufacturer: Hoeflon International B.V.  
Zwolleweg 2  
3771 NR Barneveld  
T: +31(0)342 400 288  
I: [www.hoeflon.com](http://www.hoeflon.com)  
E: [info@hoeflon.com](mailto:info@hoeflon.com)

Type

Serial no.:

Delivery date:

--



## Aflevering kwitantie / Receipt of delivery / Übergabeerklärung / Aavis de livraison / Resguardo de entrega

Machine serie nr. / Machine serial no. / Maschinen  
seriennummer / Numéro de série / Número de serie

.....

Datum van aflevering / Date of delivery / Lieferdatum /  
Date de livraison / Fecha de entrega

..... - ..... - .....

Klantnaam / Customer Name / Kundenname / Nom du client /  
Nombre del cliente

.....

Adres / Address / Adresse / Adresse / Dirección

.....

Postcode / Zip code / Postleitzahl / Code postal / Código postal

.....  
Plaats / Place / Ort / Lieu / Lugar

.....  
Land / Country / Land / Pays / Pais

.....

Dealer naam / Dealer Name / Händlers name / Nom du revendeur /  
Nombre del distribuidor

.....

Adres / Address / Adresse / Adresse / Dirección

.....

Postcode / Zip code / Postleitzahl / Code postal / Código postal

.....  
Plaats / Place / Ort / Lieu / Lugar

.....  
Land / Country / Land / Pays / Pais

.....

Bij de hierboven genoemde machine ontving ik de gebruikershandleiding. Tevens zijn mij de gebruik, veiligheid en onderhoudsvorschriften uit gelegd. / In the above machine I received the user manual. I also laid down the use, safety and maintenance instructions. / In der obigen Maschine habe ich die Bedienungsanleitung erhalten. Ich habe auch die Gebrauchs-, Sicherheits- und Wartungsanweisungen festgelegt. / Dans la machine ci-dessus, j'ai reçu le manuel de l'utilisateur. J'ai également défini les instructions d'utilisation, de sécurité et de maintenance. / En la máquina de arriba recibí el manual de usuario. También establecí las instrucciones de uso, seguridad y mantenimiento.

Handtekening van de klant

Signature of the client

Unterschrift des Kunden

Signature du client

Signatura del cliente

Handtekening van de dealer

Signature of the Dealer

Unterschrift des Händlers

Signature du revendeur

Signatura del distribuidor

Dit formulier ingevuld en ondertekend terug zenden naar Hoeflon B.V. Bij voorkeur inscannen en mailen of een foto van dit ingevulde formulier mailen. / This form filled in and signed back to Hoeflon B.V. Preferably scan and mail or mail a picture of this completed form. / Dieses Formular wurde ausgefüllt und an Hoeflon B.V. Scannen und mailen Sie am besten ein Bild dieses ausgefüllten Formulars. / Ce formulaire rempli et signé à Hoeflon B.V. De préférence, numériser et poster ou poster une photo de ce formulaire rempli. / Este formulario se completó y se firmó nuevamente con Hoeflon B.V. Preferiblemente escanee y envíe por correo o correo una foto de este formulario completo.

Zonder ingevuld en retour ontvangen formulier nemen wij geen garantie aanvragen van de machine in behandeling. / Unless filled in and returned, we will not accept any warranty requests from the machine. / Sofern nicht ausgefüllt und zurückgesendet, akzeptieren wir keine Garantieforderungen von der Maschine. / Sauf si rempli et retourné, nous n'accepterons aucune demande de garantie de la machine. / A menos que se complete y devuelva, no aceptaremos ninguna solicitud de garantía de la máquina



## PREFACE

This user manual accompanies the vacuum lifter, type VL500. Read this entire user manual carefully to become familiar with the correct operation and maintenance of the vacuum lifter. If you choose to ignore the guidelines and instructions in this user manual you do so entirely at your own risk, and bodily injury and damage to the machine may result.

Hoefflon International B.V. recommends that the original copy of this user manual, including all the annexes, be kept in a safe, central place. It is also a good idea to keep a copy of this user manual near the machine at the workplace. For technical support, please contact the manufacturer (see details on the cover).

## NOTES FOR THE READER

The instructions, recommendations and warnings in this user manual are accompanied by the following terms/pictograms. Read these instructions carefully.



**TIP**

*A 'Tip' provides the user with suggestions and advice that will make it easier or more convenient to perform certain tasks.*



**CAUTION!**

'Caution!' The operation may be dangerous. 'Caution!' indicates that damage to the machine may occur if the user does not perform the procedures with due care.



**WARNING!**

'Warning!' The user may injure himself or seriously damage the machine. A warning indicates a situation in which the user may be harmed or damage may occur to the machine, tool or load if the user does not perform the procedures carefully.



**DANGER!**

**'Danger!' Warns that a hazard or hazardous condition may be life threatening.**

## PROPERTY RIGHTS

All rights reserved. No part of this publication may be reproduced, stored in a retrieval system, or transmitted in any form or by any means (electronically or mechanically, including photocopying, recording or otherwise) without the prior written permission of Hoefflon International B.V. This also applies to the accompanying drawings and charts. © Copyright 2017

## Table of contents

**PREFACE ..... 5**

<b>NOTES FOR THE READER</b> .....	<b>5</b>
<b>PROPERTY RIGHTS</b> .....	<b>5</b>
<b>Table of contents</b> .....	<b>5</b>
<b>1. INTRODUCTION</b> .....	<b>8</b>
<b>1.1. Introduction</b> .....	<b>8</b>
<b>1.2. EC Declaration of Conformity</b> .....	<b>8</b>
<b>1.3. Changes</b> .....	<b>8</b>
<b>2. GENERAL DESCRIPTION</b> .....	<b>9</b>
<b>2.1. Intended use</b> .....	<b>9</b>
<b>2.2. Versions of the vacuum lifter</b> .....	<b>9</b>
<b>2.3. Vacuum lifter components</b> .....	<b>10</b>
<b>2.4. Technical data</b> .....	<b>11</b>
2.4.1. Technical specifications.....	11
2.4.2. Drawings.....	12
2.4.3. Hydraulic system .....	13
2.4.4. Electrical system.....	13
<b>2.5. Type plate</b> .....	<b>14</b>
<b>3. GENERAL INSTRUCTIONS FOR USE</b> .....	<b>15</b>
<b>4. WARRANTY</b> .....	<b>16</b>
<b>5. SAFETY</b> .....	<b>16</b>
<b>5.1. Operating personnel</b> .....	<b>16</b>
<b>5.2. Warnings</b> .....	<b>16</b>
<b>5.3. Pictograms</b> .....	<b>20</b>
<b>6. WORKING WITH THE VACUUM LIFTER</b> .....	<b>22</b>
<b>6.1. Daily inspection prior to use</b> .....	<b>24</b>
<b>6.2. Controls</b> .....	<b>25</b>
Electrical cabinet .....	25
<b>6.3. Function/operation vacuum suction unit</b> .....	<b>26</b>
<b>6.4. Things to keep in mind during lifting</b> .....	<b>27</b>
6.4.1. Guiding the load .....	28
<b>6.5. Tilting and rotating the vacuum lifter.</b> .....	<b>29</b>
<b>6.6. Various configurations</b> .....	<b>30</b>
6.6.1. Installing/removing extra suction cups .....	30

6.6.2.	Battery charger.....	31
<b>6.7.</b>	<b>Options .....</b>	<b>32</b>
6.7.1.	Remote control.....	32
6.7.2.	Transport dolly .....	33
<b>7.</b>	<b>MAINTENANCE / MALFUNCTIONS .....</b>	<b>34</b>
7.1.	General .....	34
7.2.	Maintenance work .....	35
7.3.	Maintenance schedule .....	35
7.4.	Inspections .....	35
7.5.	Troubleshooting .....	36
<b>8.</b>	<b>TRANSPORT, STORAGE, DISPOSAL .....</b>	<b>38</b>
8.1.	Transport .....	38
8.1.1.	Instructions for transport/lifting .....	38
8.1.2.	Securing .....	39
8.2.	Disposal .....	39
<b>9.</b>	<b>ANNEXES .....</b>	<b>40</b>
9.1.	EC Declaration of Conformity .....	40

## 1. INTRODUCTION

### 1.1. Introduction

The purpose/function of this user manual is to establish safe and efficient interaction between man and machine. The information in this user manual plays an important role in ensuring the safe and proper operation of the machine.

Read this user manual carefully from beginning to end. Hoeflon International B.V. also recommends a (brief) compulsory training and instruction session for all new users (operators, technicians, maintenance personnel and possibly even cleaners), for which this manual can serve as a starting point.

Contact your supplier's technical department for additional information concerning aspects such as maintenance and repair of specific machine parts. This user manual has been written with the greatest possible care and with the intention of making it as complete as possible. Nevertheless, continuous safety vigilance in both familiar and unfamiliar situations is always necessary.

### 1.2. EC Declaration of Conformity

Hoeflon International B.V. declares that the vacuum lifter meets the requirements of the applicable European Directives. The EC Declaration of Conformity is attached as an annex.

### 1.3. Changes

Changes may only be made to the vacuum lifter after written consultation with Hoeflon International B.V.

All changes to the machine must be documented in this user manual as well as in all copies. The party that makes the changes is responsible for doing so.

Hoeflon International B.V. reserves the right to make immediate adaptations or changes that improve the safety of the machine at any time. These adaptations or changes will be documented in an annex to this user manual. The content of this user manual can also be changed without prior notice.

## 2. GENERAL DESCRIPTION

### 2.1. Intended use

The vacuum lifter is exclusively intended for placing/moving non-permeable, shape-retaining, flat material, such as glass, steel and natural stone. The objects to be transported must fall within the specifications described in the user manual.

The environmental conditions required for proper operation of the vacuum lifter are also described herein.

The operation and results are partially dependent on the user's skill level. The many variables involved make it impossible to provide any well-founded (daily) production figures.

The vacuum lifter is intended for indoor and outdoor use.

The vacuum lifter can, as an option, be operated from a remote control. The hand control and remote control may not be used simultaneously.

### 2.2. Versions of the vacuum lifter

The version you have is shown on the title page of the user manual that accompanies your machine. The type designation is also shown on the type plate.

The machine may also be equipped with the following options:

- Radio remote control for switching the vacuum on and off remotely.
- Transport dolly for easy transport of the vacuum lifter.

### 2.3. Vacuum lifter components

The components of the vacuum lifter are shown below.

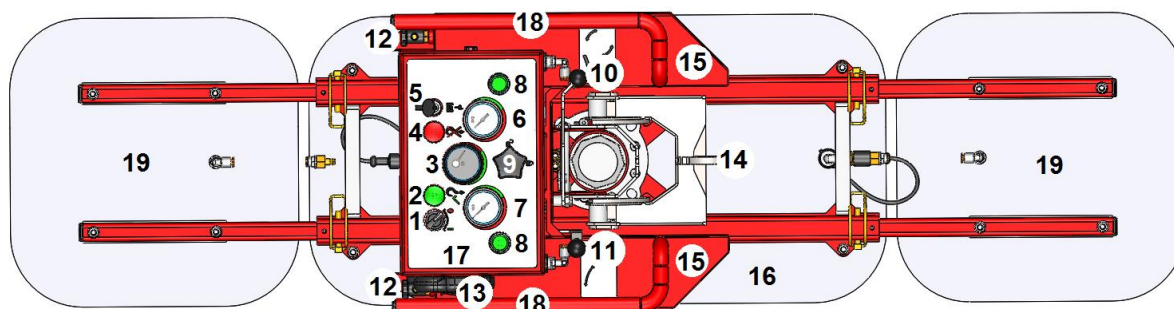

Figure: 1

- |                            |                           |
|----------------------------|---------------------------|
| 1 Main switch              | 11 Toggle (tilt)          |
| 2 Indicator lamp           | 12 Drain tap              |
| 3 Voltmeter                | 13 Remote control         |
| 4 Warning lamp             | 14 Lifting eye            |
| 5 Socket (charging)        | 15 Buffer tank            |
| 6 Vacuum gauge (circuit 1) | 16 Suction cup            |
| 7 Vacuum gauge (circuit 2) | 17 Control cabinet        |
| 8 Push button              | 18 Handle                 |
| 9 Latch                    | 19 Removable suction cups |
| 10 Toggle (rotate)         |                           |

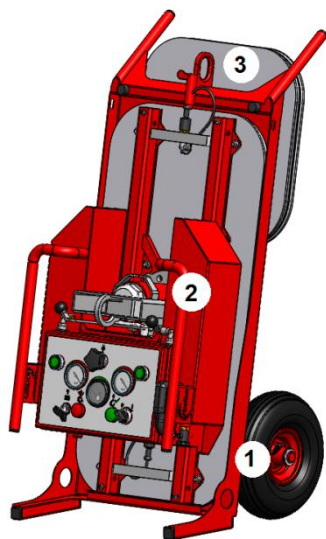

Figure: 2

- |   |
|---|
| 1 Transport dolly                           |
| 2 Main suction unit with electrical cabinet |
| 3 2x add-on suction cup                     |

### 2.4. Technical data

#### 2.4.1. Technical specifications

The technical data for the vacuum lifter are shown below.

General data	
Machine brand	Hoeflon
Serial number	03 12 1089 VL500 (1089=service number)
Tilting range	90° (with lock in vertical and horizontal positions)
Rotation range	360° (infinitely rotatable with lock every 90°)
Maximum wind speed	5.5 m/s (4 Beaufort)
Elevation for use	Max. 1200 m above sea level
Ambient temperature	0 to 40 °C
Battery	12V, 12Ah LiFePO4
Specifications VL500	
Type	VL500
Length	1630 mm
Width	220 mm
Height	495 mm
Total weight	52 kg
Max. working load	500 kg

### 2.4.2. Drawings

The top and side views of the vacuum lifter are shown below.

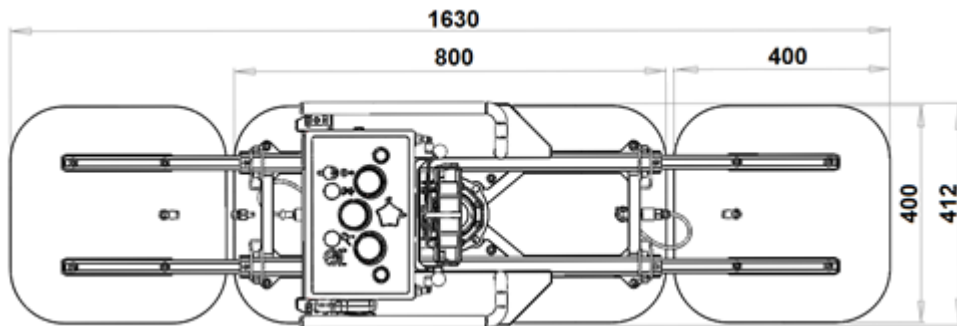

Figure 3: top view

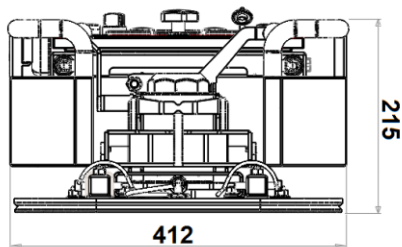

Figure 4: side view

### 2.4.3. Hydraulic system

The specifications for the hydraulic system are shown below.

Pneumatic system	
Implementation	Double circuit
Volume buffer tank per circuit	3.3 litres
Vacuum pump	12 V membrane pump

### 2.4.4. Electrical system

The specifications for the electrical system are shown below.

Electrical system	
Battery	12 V, 12 Ah, LiFePO4
Remote control (option)	Teleradio Panther 2405-2480 MHz

## 2.5. Type plate

A type plate containing the machine data is mounted on the vacuum lifter. This type plate may not be removed.



Figure: 5

The CE Marking is shown on the type plate to indicate that the vacuum lifter meets the requirements of applicable European directives.

Type plate explanation	
Type	The type of vacuum lifter (VL500)
Model	The brand of the vacuum lifter
Serial no.	The serial number of the vacuum lifter
Year	The year in which the vacuum lifter was built
Weight	The weight of the vacuum lifter
Max. capacity	Maximum working load



**TIP**

*Please provide the type number and serial number when ordering parts.*

### **3. GENERAL INSTRUCTIONS FOR USE**

The vacuum lifter is exclusively intended for placing/moving non-permeable, shape-retaining material, such as glass, steel and natural stone. The objects to be transported must fall within the specifications described in the user manual. It is also absolutely forbidden to exceed the maximum working load. If changes are desired, you must contact the manufacturer.

Before the machine is put in use the user must be sufficiently familiar with this user manual. All the instructions and safety warnings in this user manual must be followed. Any use other than the permitted use may result in danger to users and bystanders. Moreover, the machine may also be damaged. It is not permitted to use the machine in a way other than prescribed without express written permission from Hoeflon International B.V.

Every employee must be familiar with all the instructions in this user manual. Failure to heed this requirement is considered to be negligence.

## 4. WARRANTY

A new vacuum lifter is covered by a 12-month warranty.

The warranty starts on the day the vacuum lifter is first put in use. This is also the day that is stated on the warranty form.

If changes are made to the vacuum lifter by anyone other than a Hoeflon International B.V. employee, the warranty will be void.

No warranty is given on the following parts:

- Imitation parts or parts that were not ordered from Hoeflon International.
- Labour charges for installation/repair of the vacuum lifter.
- Parts that have become defective due to incorrect/improper use, overloading, lack of maintenance, incompetence, accidents, normal wear, etc.
- Parts required for scheduled maintenance.
- If a completed warranty form is not returned to Hoeflon International B.V.,
- reimbursement will only be provided for the parts.

The full terms and conditions of the warranty are available from your dealer on request.

## 5. SAFETY

### 5.1. Operating personnel

Operating personnel may not be under the influence of narcotics or alcohol and must be at least 18 years of age. These persons must be familiar with all the functions and tools associated with this vacuum lifter. Persons who work with the vacuum lifter must wear safety shoes, gloves and a safety helmet.

### 5.2. Warnings

Every employee must heed the following warnings/regulations.



**DANGER!**

It is prohibited to slew a crane over persons with the vacuum lifter attached.



**DANGER!**

Never allow unauthorised persons to come within the working range of the machine while it is in operation.



**DANGER!**

It is prohibited to work with the vacuum lifter if its lifting eye is weak or damaged.



**DANGER!**

Avoid contact with rotating parts.



**DANGER!**

It is prohibited to use the vacuum lifter in the vicinity of high voltage cables!



**DANGER!**

Never climb on the machine when it is in motion or when it is being used.



**DANGER!**

It is prohibited to use the vacuum lifter in an explosive environment.



**DANGER!**

It is prohibited to use the vacuum lifter to transport or lift persons.



**DANGER!**

It is prohibited to use the vacuum lifter to pull loads free, push them or pull them at an angle.



**DANGER!**

It is prohibited to bypass a sensor; doing so can cause danger to life and damage to the machine. Contact Hoeflon International B.V. immediately in the event of a defective sensor.



**DANGER!**

It is forbidden to change the vacuum lifter settings; this can lead to dangerous situations and damage to the machine and immediately voids the warranty.



**DANGER!**

Do not lift loads that exceed the maximum permitted working load.



**DANGER!**

Never leave the machine unattended with a load hanging from the vacuum lifter.



**DANGER!**

Only move loads that can move freely from the surface they are sitting on and that are located with their middle beneath the lifting eye!



**DANGER!**

Never place material or tools on the vacuum lifter; they may fall off during use or damage the machine.



**DANGER!**

It is prohibited to use the vacuum lifter during rain, snow, thunderstorms and/or in wind speeds in excess of 5.5 m/s.



**DANGER!**

It is prohibited to use the vacuum lifter at temperatures below 0 °C.



**DANGER!**

It is prohibited to use the vacuum lifter at elevations higher than 1200 metres above sea level.



**DANGER!**

Never use the vacuum lifter if the moving parts and extra suction cups are not securely attached; this can lead to dangerous situations and machine damage.



**DANGER!**

It is prohibited to lift wet or damp material.



**DANGER!**

It is prohibited to use the hand control at the same time the optional radio remote control is in use.



**DANGER!**

The vacuum lifter is not suitable for lifting flexible sheets or loads which, due to their large dimensions, will bend too much.



**WARNING!**

Only suitable, trained persons who are familiar with the content of this user manual and have completed the user training provided by Hoeflon International B.V. may operate or work with the vacuum lifter!



**WARNING!**

Dangerous situations can easily arise in which there is intense interaction between the vacuum lifter, the operator, the load, the surroundings and the machine to which the vacuum lifter is attached. Thorough knowledge and preparation is a must.



**WARNING!**

It is forbidden to expose the electrical system to rain, snow or a humid environment.



**WARNING!**

The main switch must be in the off position while the battery is being charged.



**CAUTION!**

Mind the height restriction in covered areas.



**CAUTION!**

When working in a poorly lit environment, artificial light must be used to ensure that operations involving the vacuum lifter can be performed safely.



**CAUTION!**

Never leave the machine unattended at a work site while it is switched on.



**CAUTION!**

Never leave the remote control unattended while the machine is switched on.



**TIP**

*Use communication equipment if the operator does not have a complete overview of the working area of the vacuum lifter.*



**TIP**

*Keep the vacuum lifter clean and prevent accumulation of contamination.*









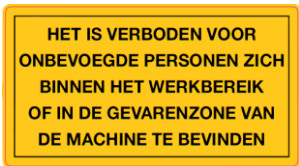

**TIP**

*Follow national regulations concerning working conditions and work safety when using the vacuum lifter.*

### 5.3. Pictograms

The pictograms used are shown below. These may not be removed. Missing or damaged pictograms must be replaced immediately!

Pictogram	Meaning	Location
	Use of safety shoes, gloves and safety helmet is mandatory.	On the left buffer tank.
	Lifting point for lifting the machine.	Beside the lifting eye on the suction unit and on top of the optional transport dolly.
	L to R: Do not use in the vicinity of high voltage cables; Suspended load; It is prohibited to be under the load.	On the right buffer tank.
	It is prohibited for unauthorised persons to be within the working range or DANGER ZONE of the machine.	On the right buffer tank.
	Check that all safety devices are installed correctly before starting up the machine.	On the right buffer tank.
	Always consult the user manual before taking any action.	On the right buffer tank.
	Risk of cutting or severing	On the left and right buffer tanks.

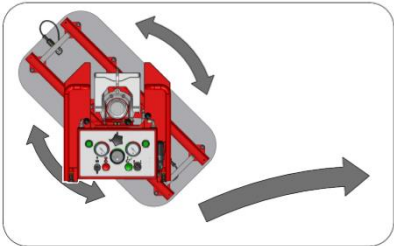
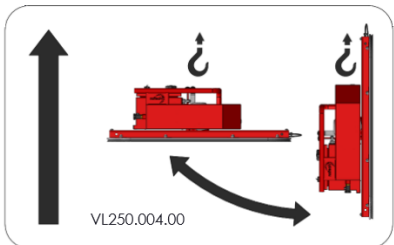
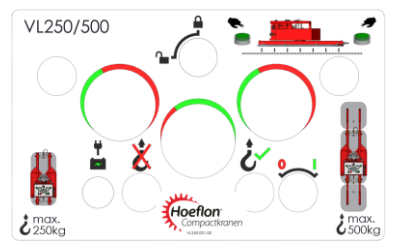
Pictogram	Meaning	Location
	<p>Risk of trapping hands.</p>	<p>On the left and right buffer tanks.</p>
	<p>Warning for radio remote control.</p>	<p>On the right buffer tank.</p>
	<p>Rotation of the suction cup.</p>	<p>On top of the left buffer tank.</p>
	<p>Tilting of the suction cup.</p>	<p>On top of the right buffer tank.</p>
	<p>Explanation of control panel on the electrical cabinet.</p> <p>The maximum lifting capacity in the two different configurations is also shown here.</p>	<p>On the top of the electrical cabinet.</p>

## 6. WORKING WITH THE VACUUM LIFTER

Every employee must observe the following rules/warnings while working with the vacuum lifter.



**DANGER!**

Never enter the working area; this can have serious consequences.



**DANGER!**

Do not let unauthorised persons enter the working area of the vacuum lifter.



**DANGER!**

It is prohibited to use the vacuum lifter in an explosive environment!



**DANGER!**

The user is responsible for safe use of the vacuum lifter (based on intended use, capacity, validity of inspection stickers and visual inspection) and the personal safety of the operator and people in the vicinity.



**WARNING!**

Work safely at all times, taking into account the vacuum lifter, surroundings and load. Do not begin working if there is a plausible risk of a dangerous situation developing before appropriate measures have been taken.



**WARNING!**

Operate the machine with which the vacuum lifter is lifted with care; never release the toggles suddenly and prevent jolts while driving, slewing and lifting. May only be operated by authorised persons!



**WARNING!**

Always perform the daily inspection first!



**WARNING!**

Always ensure that no hazardous situation can develop!



**WARNING!**

Ensure that the vacuum lifter working area is tidy and cordoned off.



**CAUTION!**

Do not use the vacuum lifter until precautions have been considered and taken to safeguard the user, machine, load and surroundings.



**CAUTION!**

The vacuum lifter is intended for indoor and outdoor use.



**CAUTION!**

When it is necessary to perform other related work, ensure that there is no longer any load on the vacuum lifter and switch off the controls to prevent unintentional movements.



**CAUTION!**

Never leave the controls unattended.



**CAUTION!**

Never place loose objects on the vacuum lifter.

---

### 6.1. Daily inspection prior to use

For your own safety and to obtain the maximum service life from your equipment, it is of great importance that you always inspect the condition of the vacuum lifter before use. Resolve any problems you find, or have your dealer do so, before you use the vacuum lifter again.

- Place the vacuum lifter on a flat, stable surface.
- Check that the main switch is in the ( 0 ) position (see figure 9).
- Perform a thorough general visual inspection of the vacuum lifter. Check for loose connections, accumulated dirt and any damage. Remove any dirt which has accumulated and have necessary repairs performed if you observe a leak.
- Make sure that the locking pins are present and secure.
- Check whether the toggles for operating the tilt and rotation movements automatically return to the locked position.
- Check the control functions.
- Check the sealing rubber of the suction cup for damage (see figure 6). Replace damaged rubbers.
- Place the vacuum lifter in the vertical position, open both water drain taps at the bottom of the buffers (see figure 7) to allow condensation water to drain out of the buffers. When no more water runs out, close the valves.
- Put the main switch in position ( 1 ).
- Check the operation of the two green buttons ( 8 in figure 9) of the vacuum circuit.
- Check the rubber of the suction cup to make sure it is not dirty or greasy, and clean if necessary.
- Check the air filters on the bottom of the suction cup to make sure they are clean (see figure 8).
- Check whether the battery is sufficiently charged; the voltmeter indicator should be between 11 and 13 volts with the pump running. When the pump is not running, the voltmeter should be between 12 and 13 volts. Otherwise the battery is discharged or the machine is switched off.
- Check the operation of the acoustic and optical alarm system at a vacuum level of less than -0.60 bar. This can be checked by slowly opening the water drain tap while the machine is switched on without a load. A signal should be heard and the red lamp should light.

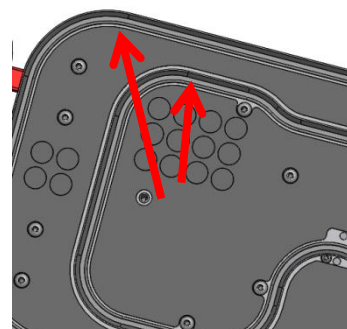

Figure: 6

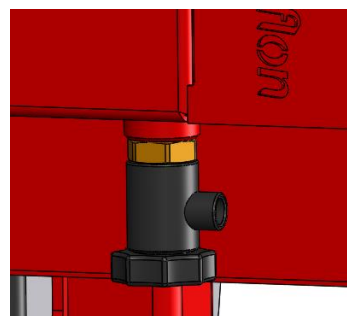

Figure: 7

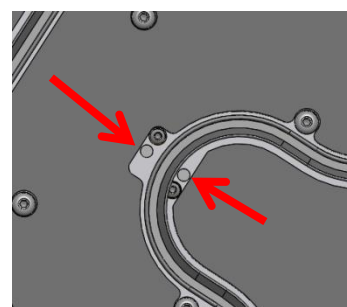

Figure: 8

### 6.2. Controls

#### Electrical cabinet

There are a number of functions present on the electrical cabinet. These functions are shown and explained below.

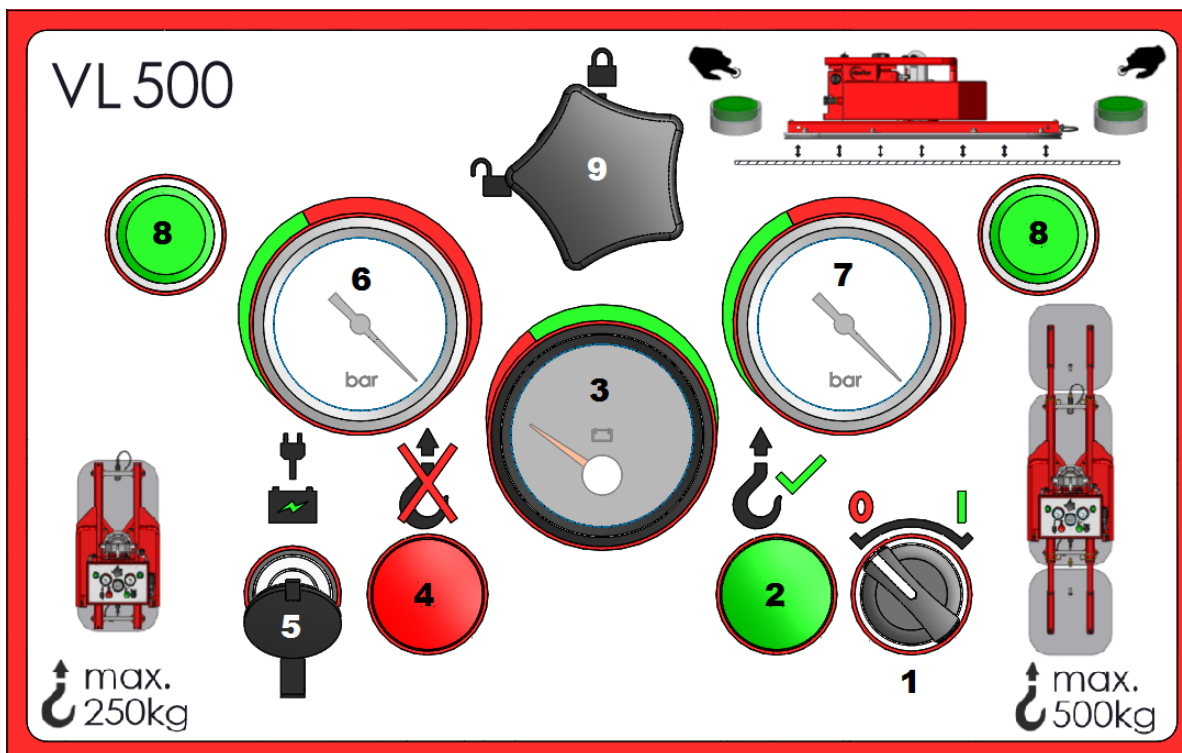

Figure: 9

Electrical cabinet		
Number	Component	Function
1	Main switch	position (0): Machine switched off. position (1): Machine switched on.
2	Warning lamp (green)	This lamp is lit if the vacuum level in both tanks is OK.
3	Voltmeter	Indicates the voltage level of the battery.
4	Warning lamp (red)	This lamp is lit if the vacuum level in one or both tanks is not OK. A signal is also audible when the lamp is lit.
5	Charging socket	The battery charger plug must be connected here to charge the battery.
6	Vacuum gauge circuit 1	This vacuum gauge indicates the vacuum level in circuit 1.
7	Vacuum gauge circuit 2	This vacuum gauge indicates the vacuum level in circuit 2.
8	Push button	These buttons switch the vacuum on and off.
9	Latch	This is used to open the electrical cabinet.

## 6.3. Function/operation vacuum suction unit



### DANGER!

If the load is covered with protective film, it must be removed before the suction cup is placed on the load.



### WARNING!

Lifting is not permitted if one or both vacuum gauges are in the red zone.



### WARNING!

Operate the machine used to lift the vacuum lifter with care; never release the toggles suddenly and prevent jolts while driving, slewing and lifting. May only be operated by authorised persons!



### TIP

*Make sure the battery is fully charged.*



### TIP

*Do not forget to switch off the main switch in the electrical cabinet after use of the vacuum lifter!*

### To lift with the vacuum lifter, follow these steps in the order shown:

- First perform the daily inspection!
- Ensure that no hazardous situations can develop!
- Hang the eye of the vacuum lifter on the crane hook (see figure 10).
- Switch on the vacuum lifter by placing the main switch in position ( 1 ) (see figure 9).
- Now the vacuum pump goes on and stops once a vacuum level of -0.70 [bar] is reached; an acoustic signal is also audible and the red lamp is lit until the required vacuum level of -0.60 [bar] has been reached. When the vacuum level is sufficient, the alarm switches off and the green lamp lights.
- Set the suction cup in the correct position.
- Place the suction cup on the load. Make sure the suction surface is dry and clean.
- Operate both push buttons ( 8 ) (see figure 9) at the same time to switch on the vacuum.
- Check the vacuum gauges to see whether the required vacuum level of -0.60 [bar] has been reached. The indicator must be in the green zone, and the vacuum pump must switch itself off. If this does not happen, the suction cup is not sealing properly or there is a leak, and it is not safe to lift!
- The load can now be moved. Once it is in place and has been secured, the hook must first be relieved of the load.
- The vacuum can now be switched off by once again pressing the buttons ( 8 ) (see figure 9).

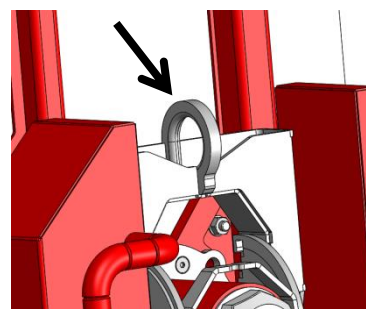

Figure: 10

- If the vacuum lifter will not be used for more than 15 minutes, it must be switched off by setting the main switch (see figure 9) to ( 0 ).

## 6.4. Things to keep in mind during lifting



### DANGER!

If one or both vacuum gauges are in the red zone and/or the acoustic alarm is on, a lifted load must be set down as soon as possible.



### WARNING!

If the vacuum pump fails during lifting, the lifted load must be set down as soon as possible.



### WARNING!

If the voltmeter on the electrical cabinet indicates a voltage below 10 volts, lifting is no longer permitted and the vacuum lifter must be set down as soon as possible.



### TIP

*It is highly recommended that a vacuum lifter be recharged immediately after use and any time the device will not be used for a longer period.*

### During lifting, the user must continuously keep the following in mind:

- The vacuum gauge indicators must always remain in the green zone during lifting.
- The acoustic and optical (red warning lamp) warning signals may not be on during lifting.

### To work safely with the vacuum lifter it is necessary that:

- The operator have a normal sense of hearing and not be wearing hearing protection.
- The operator must be within hearing and visual distance of the vacuum lifter during lifting.
- The ambient noise level must be no higher than 70 dB.
- The operator of the vacuum lifter must be in continuous contact with the operator of the lifting device and they must be able to communicate well.

### 6.4.1. Guiding the load



#### **WARNING!**

The mass, position and centre of gravity of the load must be known; this information is necessary to determine the correct position in which to place the vacuum lifter on the sheet to be lifted so that it hangs straight down.



#### **WARNING!**

Always operate the machine from which the vacuum lifter is hanging with the greatest care. Avoid abrupt movements and maintain contact with any assistants helping to guide the load.

#### Adhere to the following rules when guiding a load:

- Never place body parts (feet, legs, hands) under the load.
- During horizontal guiding of the load, follow behind the load.
- Never place body parts between the load and obstacles in the surrounding area, and never go between the load and an obstacle without a safe amount of space between them.
- When working near or with fragile material (e.g. stone, glass) where there is a risk of splinters/shards, wear protective clothing and safety glasses.
- Maintain visual contact and open channels of communication between guides and operator.
- When working with tall, unstable loads, never stand in the fall direction of the load.
- Whenever possible, use guide lines to maintain a safe distance.
- When using guide lines for a load at height, never walk under the load and maintain a safe distance, taking into account influence of the fall direction of the load due to obstacles in the environment.
- Make sure you always have an open escape route where you can flee for safety.
- Never stand or hang on the load.
- Make sure the load is properly held by the suction and is and will continue to hang stable.
- Avoid abrupt movements of the machine and load.
- When using guide lines, clear the surrounding areas to eliminate the risk of tripping and the risk that the guide line will get caught and/or damaged.

### 6.5. Tilting and rotating the vacuum lifter.



#### WARNING!

Be aware of the crushing danger during tilting and rotating. Crushing danger at the pivot points and at the load.

The suction plate of the vacuum lifter can rotate and tilt relative to the electrical cabinet with the buffer tanks.

#### Tilting:

- Lower the suction cup onto the middle point of the horizontally lying sheet.
- The lifting eye is vertical and the suction cup with buffer tanks lies horizontally.
- Operate the two green buttons to switch on the vacuum. The suction cup secures itself in place.
- If both vacuum gauges are in the green zone and the lamp is lit, it is safe to lift.
- Once the sheet has been lifted sufficiently clear of the ground it may be tilted (do this carefully so the sheet does not contact anything).
- Operate the tilt toggle (see figure 12) to the right of the lifting eye, labelled with the tilt sticker (see figure 11).
- Push the toggle forwards, in the direction indicated by the arrow on the sticker; it unlocks and can tilt the sheet 90°.
- Once the sheet is tilted, release the toggle. It automatically returns to the locked position.
- Check that the toggle has fully returned to the locked position. Test to make sure the sheet cannot tilt back.
- If it is locked properly and the vacuum is still good, you can proceed to moving the sheet.

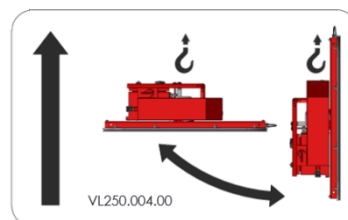

Figure: 11

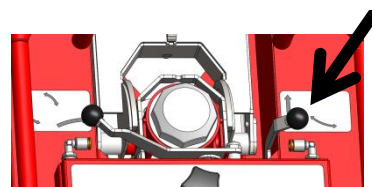

Figure: 12

#### Rotating:

- The suction cup can also be rotated relative to the electrical cabinet and buffer tanks. The suction cup is infinitely rotatable.
- If there is a sheet hanging from the vacuum lifter, the sheet can be rotated.
- Make sure the sheet is hanging free.
- Operate the rotate toggle (see figure 14), to the left of the lifting eye, labelled with the rotate sticker (see figure 13).
- Pull the toggle towards you. The rotation is unlocked and the suction cup is infinitely rotatable.
- It can be locked every 90°.
- Rotate the suction cup to the desired position and release the toggle so it locks again.
- Check that the suction cup can no longer rotate.
- If it is locked properly and the vacuum is still good, you can proceed to moving the sheet.

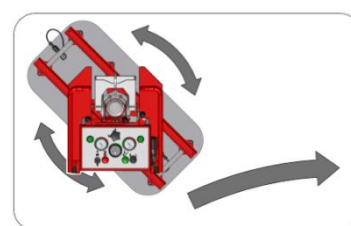

Figure: 13

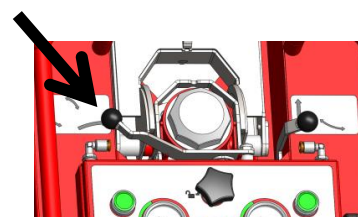

Figure: 14

## 6.6. Various configurations

The vacuum lifter can be used in two different ways. This has to do with the weight to be lifted and the size of the sheet to be lifted.

The vacuum lifter consists of the main machine, including the buffer tanks, electrical cabinet, lifting eye and the large suction cup.

The main machine can lift 250 kg.

It is also possible to attach two extra suction cups to the machine, at the right and left. With both extra suction cups installed, 500 kg can be lifted.

The stickers shown below (*figures 15 and 16*) can be found on the electrical cabinet. They show the two different lifting configurations.

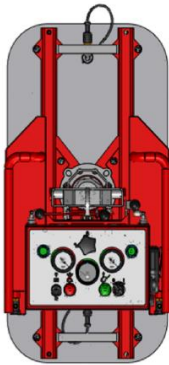

↑ max.  
250kg

Figure: 15

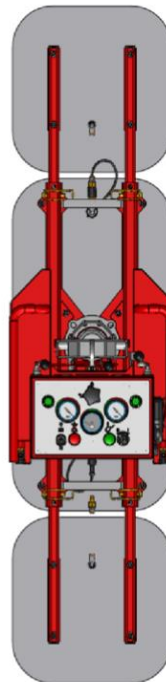

↑ max.  
500kg

Figure: 16

### 6.6.1. Installing/removing extra suction cups



**DANGER!**

It is prohibited to use the machine with one extra suction cup installed. If the extra suction cups are used, both must be installed.

- To install the extra suction cups on the main machine, proceed as follows:
- Hang the main machine (figure 15) from the lifting eye and raise it 10 cm above the ground.

- Take the first extra suction cup and slide the two extending tubes of this suction cup into the tubes on one side of the main machine.
- Slide the suction cup in to the point that the suction cup almost, but not quite, touches the suction cup of the main machine.
- Secure the extra suction cup in place by inserting a split pin into the holes in both tubes and locking them in place (see figure 17).
- Now take the other extra suction cup and insert the tubes of this suction cup into the two other tubes on the main machine in the same way.
- Now the two suction cups are located at opposite ends (see figure 16).
- Secure this second suction cup with split pins too.
- Attach the vacuum hose with quick connect from the extra suction cup to the quick coupling on the main machine (see figure 18). Do this for both extra suction cups.
- Check to make sure the extra suction cups are secure and the vacuum hoses are connected. Now the machine is ready for use and a maximum load of 500 kg can be lifted.
- To remove the extra suction cups, perform these steps in the reverse order.

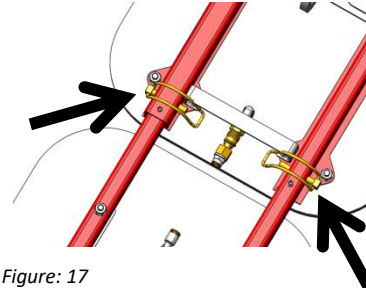

Figure: 17

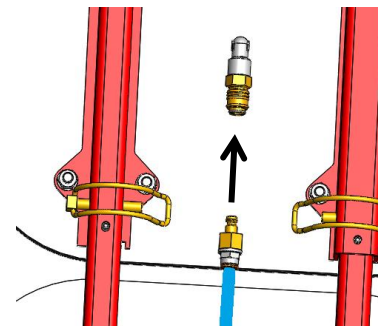

Figure: 18

### 6.6.2. Battery charger

The vacuum lifter is delivered with a battery charger. The battery charger has a lead with a 230 V mains plug on one end and a plug that fits in the socket on the electrical cabinet on the other.

#### Procedure:

- Put the main switch on the electrical cabinet in position ( 0 ).
- Open the protective cover of the charging socket on the electrical cabinet.
- Insert the round plug of the battery charger in the charging socket on the electrical cabinet.
- Insert the 230 V plug in a mains (230 V) socket.
- The battery begins to charge. A red lamp is lit on the charger.
- When the battery is fully charged a green lamp lights on the charger.
- First disconnect the 230 V plug from the mains socket, and then disconnect the plug from the electrical cabinet of the vacuum lifter.
- Cover the charging socket in the electrical cabinet with the plastic plug.
- The vacuum lifter is ready for use.

## 6.7. Options

A number of options are available for the standard vacuum lifter. These are listed below.

### 6.7.1. Remote control



#### WARNING!

The transmitter and receiver are resistant to splashed water and rain. Never clean them with high pressure or submerge them in water.



#### TIP

*Keep the transmitter clean.*

The vacuum lifter can be optionally equipped with a remote control so the vacuum can be switched on and off remotely.

The remote control works as follows:

- Switch on the vacuum lifter by placing the main switch in position ( 1 ).
- Press button ( 2 ) of the remote control (see figure 19) to switch on the vacuum.
- Press and hold buttons ( 1 and 3 ) at the same time for 10 seconds to switch the vacuum off (see figure 19).



Figure: 19

### 6.7.2. Transport dolly

An optional transport dolly is available that makes it quick and easy to move and set down the vacuum lifter. The vacuum lifter is also protected when it is on the transport dolly. The rubbers of the suction cups are then free of the frame and will therefore not be deformed or damaged.

- The vacuum lifter is placed on the front of the transport dolly.
- To take the vacuum lifter off of the transport dolly, the latch (*enlargement in figure 20*) must be released.
- Now the vacuum lifter can be lifted off of the transport dolly using the lifting eye on the vacuum lifter.
- The extra suction cups are on the back of the transport dolly (*see figure 21*).
- The extra suction cups are each secured in place by two locking pins (*see enlargement in figure 21*).
- Remove the locking pins and take the extra suction cup off of the transport dolly.
- Mount the suction cup on the vacuum lifter and secure it with the two locking pins (see section 6.6.1).
- To place the vacuum lifter on the transport dolly, perform the steps in the reverse order.
- When the vacuum lifter is on the transport dolly, the supplied protective cover can be placed over the transport dolly. This protects the vacuum lifter from damage and becoming dirty.
- The battery charger can be stored in the pocket on the front of the protective cover.

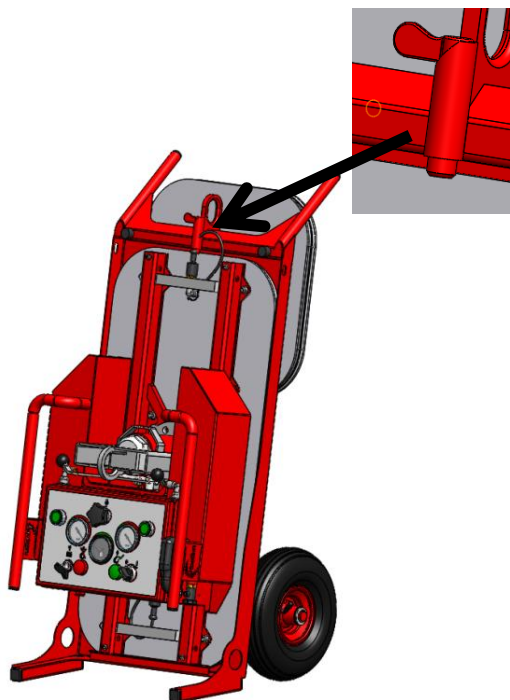

Figure: 20



Figure: 21

## 7. MAINTENANCE / MALFUNCTIONS

### 7.1. General



**DANGER!**

Put the main switch in position ( 0 ).



**DANGER!**

When the vacuum lifter is in the vertical position, the load is held in place by the friction of the rubber between the suction plate and the load. Therefore it must be clean, dry and grease-free.



**WARNING!**

Only a dealer or Hoeflon International may perform work on the electrical system of the machine.



**WARNING!**

Never use solvents, benzine or other chemicals to clean the rubber of the vacuum lifter.



**CAUTION!**

After maintenance, check whether the vacuum lifter still functions properly by testing all the functions.



**TIP**

*Place the vacuum lifter on a firm, flat surface before performing maintenance. Switch off the main switch and prevent unauthorised persons from starting the machine.*

The maintenance instructions are presented in this chapter. Proper maintenance is the key to keeping the vacuum lifter operating properly. It is very important that these instructions are followed, to ensure your safety and that of others who are present.

Unusual noises or vibrations can indicate a defect in the machine. It is then necessary to perform a repair or maintenance without delay. Consult your dealer about this.

Contact your dealer's technical department for additional information concerning aspects such as maintenance and repair of specific machine parts.

### 7.2. Maintenance work

The risk of accidents with machines is generally greater during maintenance, cleaning and service. Have maintenance work on the vacuum lifter performed by your dealer or Hoeflon International B.V. The maintenance intervals and tasks are shown in the maintenance schedule.

The tasks and intervals shown hereafter are the minimum maintenance requirements. It is advisable to shorten the maintenance intervals if conditions make this necessary, such as in the case of frequent use.

### 7.3. Maintenance schedule

Description of maintenance	Action	Interval ( o = manufacturer/dealer, ● = owner )			
		Daily	Monthly	Annually	Every 3 years
Rubber sealing profiles	Check	●			
	Replace			o	
Vacuum circuit	Check	●		o	
Rubber behind plate	Check/clean	●		o	
Complete visual inspection	Check	●		o	
Vacuum hoses	Check	●		o	
Air-tightness of vacuum system	Check	●		o	
Lifting eye and pivot points	Check	●		o	
Filters between the vacuum hoses	Check	●			
	Replace			o	
Vacuum gauges	Check	●		o	
Acoustic/optical alarm	Check	●		o	
Buffer tanks	Drain	●		o	
Control circuit vacuum pump	Check		●	o	
Bearings in vacuum control unit	Check			o	
	Lubricate			o	
Static test	Test			o	
Battery	Replace				o

### 7.4. Inspections

The vacuum lifter must be inspected annually. It is advisable to have the inspections performed by a dealer or Hoeflon International B.V.

## 7.5. Troubleshooting



### DANGER!

Put the main switch in position ( 0 ).



### WARNING!

Only the dealer or Hoeflon International may perform work on the electrical system of the machine.



### TIP



*Place the vacuum lifter on a firm, flat surface before performing maintenance. Switch off the main switch and prevent unauthorised persons from starting the machine.*

Correct operation and careful maintenance ensure that the vacuum lifter will have a long life with fewer problems.

The warnings above must be heeded for all work performed in connection with a malfunction.

A number of possible malfunctions are described hereafter. If a malfunction should occur that is not listed in the manual, contact your dealer or Hoeflon International B.V.

Malfunction	Cause	Solution
Vacuum lifter does not respond to push buttons	Vacuum valve circuit has lost its programming or is defective	Reprogram/replace
	Push button defective	Replace push button
	Vacuum valve defective	Replace vacuum valve
Remote control does not work	Remote control has lost its programming	Reprogram
	Remote control defective	Replace remote control
Malfunction	Cause	Solution

Vacuum lifter draws proper vacuum, acoustic alarm does not work, pump runs continuously	Relay K2 or K4 PM is defective	Replace relay K2 or K4
	Vacuum switch is defective or has lost its programming	Replace or reprogram
	Vacuum pump is worn out	Replace vacuum pump
	Leaking non-return valve	Clean or replace non-return valve
	Vacuum leakage	Check vacuum system for leakage
Vacuum pump does not run	Defective	Repair or replace
	Fuse blown	Replace fuse ( 10 A ) 
Vacuum lifter does not draw sufficient vacuum, acoustic alarm active	Sealing profile of the suction plate is damaged	Replace sealing profile
	Surface allows air to leak through/is too rough	Transport load by another means
Vacuum lifter draws sufficient vacuum, acoustic alarm remains on	Relay K1 or K3 is defective	Replace relay K1 or K3
	Vacuum switch is defective or has lost its programming	Replace or reprogram
	Vacuum pump is worn out	Replace vacuum pump
	Leaking non-return valve	Clean or replace non-return valve
Vacuum lifter does not work, voltmeter indicates 0 volts	Battery voltage is too low	Charge or replace battery
	Fuse blown	Replace fuse ( 10 A ) 
	Main switch defective	Replace main switch

## 8. TRANSPORT, STORAGE, DISPOSAL

### 8.1. Transport

#### 8.1.1. Instructions for transport/lifting



#### WARNING!

Only use suitable lifting accessories with the correct capacity for the lifting application. The lifting accessories must be accompanied by a certificate, have a periodic inspection, be visually inspected and have been found to be suitable for use.



#### WARNING!

Do not store the vacuum lifter resting on the sealing rubbers!

- The preferred method of transporting the vacuum lifter is on the specially designed transport dolly (see section 6.7.2).
- Place the protective cover over the transport dolly. This protects the vacuum lifter from damage and becoming dirty.
- Do not place the vacuum lifter on the sealing rubbers for transport or storage. This can damage and/or deform them.
- Only lift the vacuum lifter by the lifting eye!

#### Preparation for storage longer than 3 months

- Remove any dirt and clean the machine with water and e.g. car wash shampoo.
- Touch up any damage to the paintwork.
- Grease the parts that may rust.
- Place the vacuum lifter in a dry location, protected from rain, heat and cold.
- Disconnect the battery by unplugging the connector at the battery (see figure 22).
- Ensure that the vacuum lift cannot be activated by unauthorised persons.

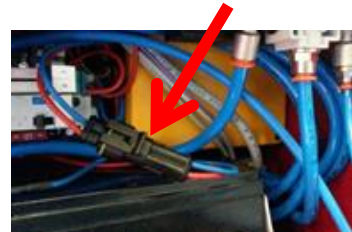

Figure: 22

#### Complete the following steps after long-term storage of the vacuum lifter.

- Connect the battery.
- Charge the battery.
- Perform the daily inspection.

## 8.1.2. Securing



### WARNING!

Overloaded eyes can cause damage to the machine. Therefore always heed the following instructions.



### WARNING!

Folding a lashing strap double also doubles the applied tension.

- If the vacuum lifter is on the transport dolly, the transport dolly can be secured as follows (see figure 23). There are two holes at the bottom of the transport dolly. These can be used to secure the transport dolly in place with lashing straps.
- If the vacuum lifter is not on the transport dolly, it must be placed on wooden beams. Place two wooden beams under the suction cup. Make sure the beams do not contact the narrow sealing rubbers (see figure 24).
- Secure the vacuum lifter with a lashing strap over the handles and buffer tanks. Make sure the lashing strap does not contact any control buttons or toggles.

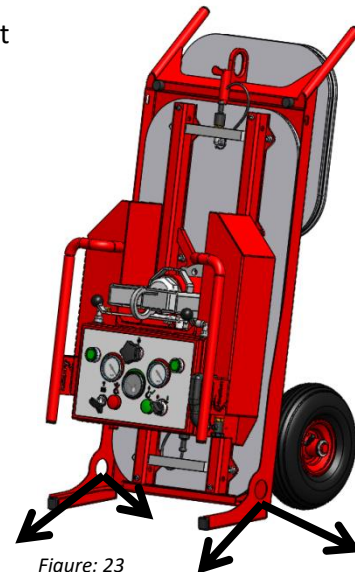

Figure: 23

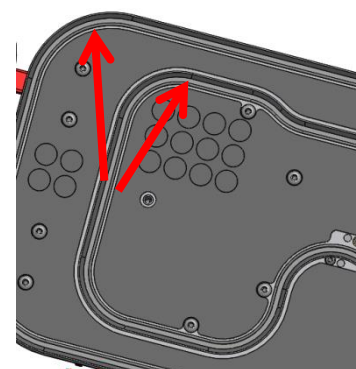

Figure: 24

## 8.2. Disposal

Dispose of waste in accordance with the applicable local regulations. Incorrect disposal of waste can be harmful to the environment. Environmentally harmful waste includes: engine oil, diesel fuel, hydraulic oil, differential oil, coolant, filters, batteries and greases.

## 9. ANNEXES

### 9.1. EC Declaration of Conformity