

# HOEFLON®

---

## User Manual

### COMPACT CRANE C10



---

Serial no.:

Delivery date:

Reference: U.C10.00.00.EN

Version: 2.0

## VERSION

Versie 1.0	03-04-2018	From serial number:
Versie 2.0	18-05-2021	From serial number:

**Manufacturer:**

Hoeflon International B.V.  
Zwolleweg 2  
3771 NR Barneveld

T: +31(0)342 400 288  
I: [www.hoeflon.com](http://www.hoeflon.com)  
E: [info@hoeflon.com](mailto:info@hoeflon.com)

## PROPERTY RIGHTS

All rights reserved. No part of this publication may be reproduced, stored in a retrieval system, or transmitted in any form or by any means (electronically or mechanically, including photocopying, recording or otherwise) without the prior written permission of Hoeflon International B.V. This also applies to the accompanying drawings and charts.

© Copyright 2021

---

## PREFACE

This user manual is for the compact crane, type C10. Throughout the rest of this document both types will simply be referred to as 'compact crane'. Read this entire user manual carefully to become familiar with the correct operation and maintenance of the compact crane. If you choose to ignore the guidelines and instructions in this user manual you do so entirely at your own risk, and bodily injury and damage to the machine may result.

Hoeflon International B.V. recommends that the original copy of this user manual, including all the annexes, be kept in a safe, central place. It is also a good idea to keep a copy of this user manual near the machine at the workplace. For technical support, please contact the manufacturer (see details on the cover).

## NOTES OF THE READER

The instructions, recommendations and warnings in this user manual are accompanied by the following terms/pictograms. Read these instructions carefully.



**TIP**

A 'Tip' provides the user with suggestions and advice that will make it easier or more convenient to perform certain tasks.



**CAUTION!**

'Caution!' The operation may be dangerous. 'Caution!' indicates that damage to the machine may occur if the user does not perform the procedures with due care.



**WARNING!**

'Warning!' The user may injure himself or seriously damage the machine. A warning indicates a situation in which the user may be harmed or damage may occur to the machine, tool or load if the user does not perform the procedures carefully.



**DANGER!**

'Danger!' Warns that a hazard or hazardous condition may be life threatening.

## Table of contents

<b>VERSION</b>	<b>2</b>
<b>Table of contents</b>	<b>4</b>
<b>1. INTRODUCTION</b>	<b>7</b>
1.1 Introduction	7
1.2 EC Declaration of Conformity	7
1.3 Changes	7
<b>2. GENERAL DISCRIPTION</b>	<b>8</b>
2.1 Intended use	8
2.2 Major components of compact crane	8
2.2.1 Technical specifications	9
2.2.2 Drawings	11
2.2.3 Sound pressure level	11
2.2.4 Hydraulic system	11
2.2.5 Electrical system	12
2.3 Type plate	13
<b>3. GENERAL INSTRUCTIONS FOR USE</b>	<b>14</b>
<b>4. WARRANTY</b>	<b>15</b>
<b>5. SAFETY</b>	<b>16</b>
5.1 Operating personnel	16
5.2 Warnings	16
5.3 Emergency stop	19
5.4 Emergency control	19
5.5 Pictograms	20
5.6 Signal column	22
<b>6. WORKING WITH THE COMPACT CRANE</b>	<b>23</b>
6.1 Daily inspection prior to use	25
6.2 Controls	27
6.2.1 Remote control	27
6.2.2 Function mapping	29
6.2.3 Calibrate levers	30
6.2.4 Changing the transmitter battery	31
6.2.5 Electrical cabinet	32

---

6.3	Crane functions/operation	33
6.3.1	Order of operations	33
6.3.2	Operation	33
6.3.3	Guiding the load	34
6.4	Driving the compact crane	35
6.4.1	Sequence of operations for starting crane	36
6.4.2	Setting track width	37
6.4.3	Transport position	37
6.5	Setting the outriggers	38
6.5.1	Order of operations	38
6.5.2	Operation	39
6.5.3	Interpreting the display while setting the outriggers	41
6.6	Attachment/Removal	42
6.6.1	Jib	42
6.7	Function/operation winch	44
6.7.1	Order of operations without options	45
6.7.2	Order of operations for use with jib	48
6.7.3	Order of operations winch head and manual jib extension plus additional 30 degree adjustable section	49
6.7.4	Positions of winch head in 30° section when used with main boom	50
6.7.5	Positions of winch head in 30° section when used with jib	51
6.7.6	Limits	52
6.7.7	Attachment winch weight	54
6.7.8	Explanation of display during lifting	57
<b>7.</b>	<b>MAINTENANCE/ TROUBLESHOOTING</b>	<b>58</b>
7.1	General	58
7.2	Maintenance work	59
7.3	Maintenance schedule	60
7.4	Lubrication chart	61
7.5	Lubricant specifications	62
7.5.1	Boom extension and retraction chains	62
7.6	Use of start assistance terminals	63
7.6.1	Preparation	63
7.6.2	Procedure	63
7.7	Battery charger	64
7.8	Removing/installing ballast	66
7.8.1	Removing ballast	66
7.9	Troubleshooting	69

---

7.9.1	Fault codes	71
7.10	Emergency control	74
<b>8.</b>	<b>TRANSPORT, STORAGE, DISPOSAL</b>	<b>78</b>
8.1	Transport	78
8.1.1	General	78
8.1.1	Securing	79
8.2	Storage	80
8.3	Disposal	80
<b>9.</b>	<b>ANNEXES</b>	<b>81</b>
9.1	Load chart C10	81
9.2	Outrigger pressure	83
9.3	Annexes	84

# 1

## INTRODUCTION

---

### 1.1 Introduction

The purpose/function of this user manual is to establish safe and efficient interaction between man and machine. The information in this user manual plays an important role in ensuring the safe and proper operation of the machine.

Read this user manual carefully from beginning to end. Hoeflon International B.V. also recommends a brief compulsory training and instruction session for all new users (operators, technicians, maintenance personnel and possibly even cleaners), for which this user manual can serve as a starting point.

Contact your supplier's technical department for additional information concerning aspects such as maintenance and repair of specific machine parts. This user manual has been written with the greatest possible care and with the intention of making it as complete as possible. Nevertheless, continuous safety vigilance in both familiar and unfamiliar situations is always necessary.

### 1.2 EC Declaration of Conformity

Hoeflon International B.V. declares that the compact crane meets the requirements of the applicable European Directives. The EC Declaration of Conformity is attached as an annex.

### 1.3 Changes

Changes may only be made to the compact crane after written consultation with Hoeflon International B.V. These changes must be documented in the crane logbook.

All changes to the machine must be documented in this user manual as well as in all copies. The party that makes the changes is responsible for doing so.

Hoeflon International B.V. reserves the right to make immediate adaptations or changes that improve the safety of the machine at any time. These adaptations or changes will be documented in an annex to this user manual. The content of this user manual can also be changed without prior notice.

# 2

## GENERAL DESCRIPTION

---

### 2.1 Intended use

The Compact Crane is exclusively intended for hoisting and lifting loose materials using a hook. The objects to be transported must fall within the specifications described in this user manual and the corresponding crane logbook.

### 2.2 Major components of compact crane

The components of the compact crane are shown below.

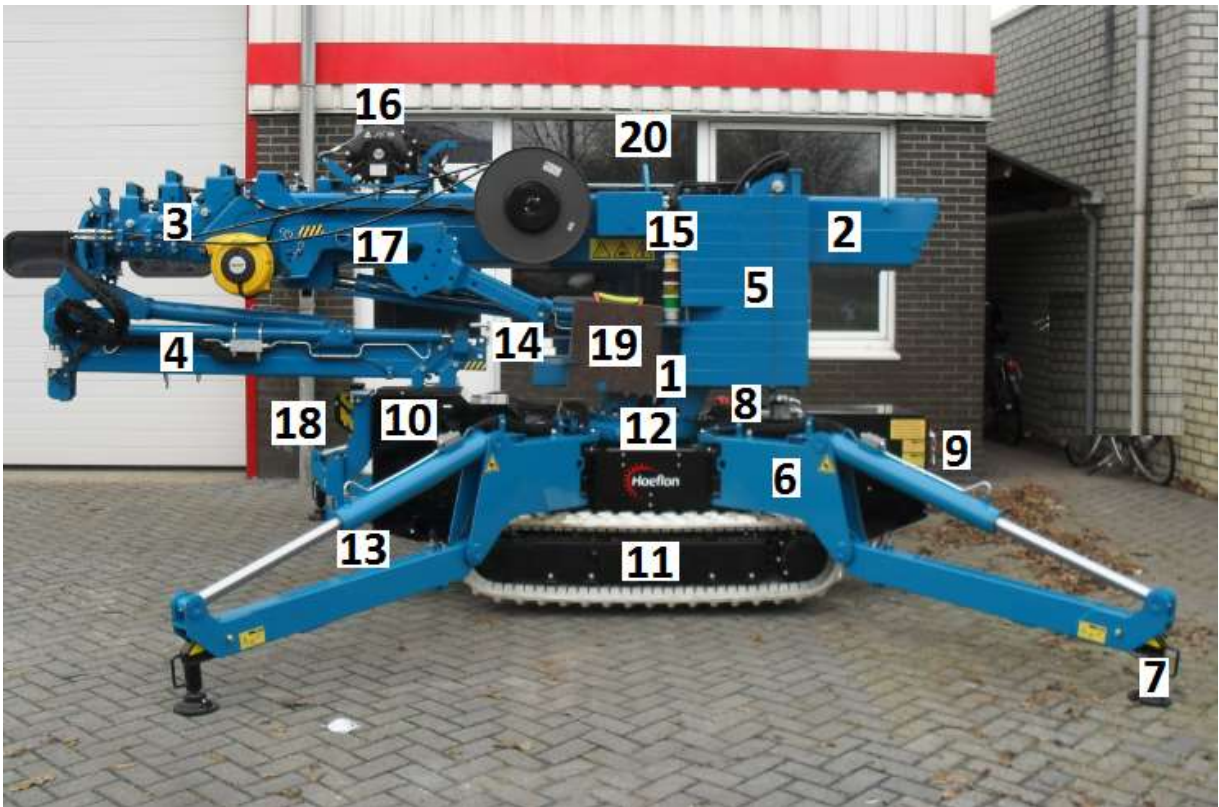

Figure:1

1 Crane column	11 Track undercarriage
2 Boom 1	12 Turntable
3 Extension jib 2 to 5	13 Drawbar eye
4 Jib	14 Storage box
5 Ballast	15 Warning lights
6 Outrigger leg	16 Winch
7 Extendable stabiliser leg	17 Storage location winch head + 30° section
8 400V machine power supply on RR outrigger	18 Storage location hoist block and ballast support
9 Electrical cabinet	19 Storage location outrigger pads
10 Powerpack	20 Compact crane lifting point

## 2.2.1 Technical specifications

The technical data for the compact cranes are shown below.

General data		
Machine brand	Hoeflon	
Serial number	03 12 1089 C10 (1089=service number)	
Jib weight	220	kg
Maximum slope angle	15	°
Clearance angle	24	°
Max. lean angle with outriggers	5	°
Ground clearance	150	mm
Diesel engine	Yanmar 3 cylinder 7.3 kW	
Electric motor	400V 50 Hz 5.5 kW	
Fuel tank volume Yanmar	20	L
Engine oil volume Yanmar	2.7	L
Battery	12 V, 44 Ah	
Ambient temperature	-10 to 40	°C
Slewing angle	360	°
Maximum working load crane	See load table provided in the annexes	
Maximum wind speed	10.8 (6 Beaufort)	m/s

Centre of gravity	Under the lifting hook on the top of the boom and 950 mm from underside of crawler track.	
-------------------	---	--

Technical data	C10	
Transport length without jib	3,900	mm
Transport length with jib	4,100	mm
Transport width	800	mm
Transport height	1,930	mm
Max. space outriggers extended at 45°	4,578 x 4,578	mm
Total weight incl. jib and any ballast	4,700	kg
Total weight jib	220	kg
Total weight jib tube	24	kg
Total weight ballast	1320	kg
Weight of winch weight with hook	33	kg
Weight of winch head	16	kg
Weight 30° section	16	kg
Maximum ground pressure per surface area	26	kg/cm <sup>2</sup>
Maximum outrigger pressure per outrigger	5,200	kg
Max. load jib horizontal retracted	1,200	kg
Max. load jib horizontal extended	575	kg
Max. load 30° section and winch head	4,000	kg
Max. winch load	1,000	kg
Max. reeving	1x reeving 2000 kg 2x reeving 4000 kg	

## 2.2.2 Drawings

The views of the compact crane are shown below.

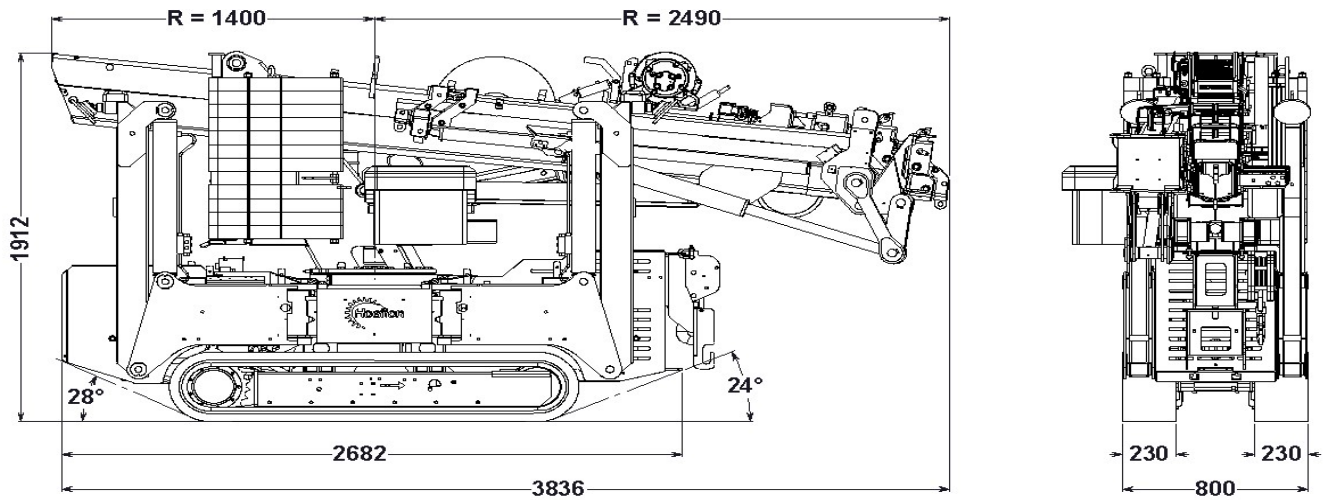

Figure: 2

## 2.2.3 Sound pressure level

The noise measurements were conducted on a flat surface.

Noise level dB(A)		8 metres	16 metres
Front, engine side	1500 rpm	63.9	57.8
Rear, control side	1500 rpm	57.7	50.3
Front, engine side	Electric motor	51.3	51.5
Rear, control side	Electric motor	54.5	51.5

## 2.2.4 Hydraulic system

The specifications for the hydraulic system are shown below.

Hydraulic system		
Volume of hydraulic tank	40 litres	
Pump 1	Type	gear pump
	Max. pressure	250 bar
Pump 2	Type	gear pump
	Max. pressure	250 bar

## 2.2.5 Electrical system

The specifications for the electrical system are shown below.

Electrical system	
Battery	12V 44Ah
Electric motor	400V 50Hz 5.5kW
Remote control	Hoeflon

**TIP**

For more technical specifications see the associated crane logbook.

## 2.3 Type plate

A type plate containing the machine data is mounted on the compact crane. This type plate may not be removed.



Figure 3:

The CE Marking is shown on the type plate to show that the compact crane meets the requirements of applicable European Directives.

Type plate explanation	
Type	The type compact crane (C10)
Brand	The brand of the compact crane
Serial no.	The serial number of the compact crane
Year of manufacture	The year in which the compact crane was built
Weight	The weight of the compact crane
Max. capacity	Maximum working load



### TIP

Please provide the type number and serial number when ordering parts.

# 3

## **GENERAL INSTRUCTIONS FOR USE**

---

The compact crane is a machine intended for lifting loads. It is only permitted to use the compact crane for the intended uses. Additionally, you are not permitted to change movement speeds on your own. Also it is absolutely prohibited to exceed the maximum working load (see section 9.1), and it is forbidden to bypass sensors. If changes are desired, you must contact the manufacturer.

Before the machine is put in use the user must be sufficiently familiar with this user manual. All the instructions and safety warnings in this user manual must be followed. Any use other than the permitted use may result in danger to users and bystanders. Moreover, the machine may also be damaged. It is not permitted to use the machine in a way other than prescribed without express written permission from Hoeflon International B.V.

Every employee must be familiar with all the instructions in this user manual. Failure to heed this requirement is considered to be negligence.

# 4

## WARRANTY

---

A new compact crane is covered by a 12-month warranty.

The warranty starts on the day the compact crane is first put in use. This is also the day that is stated on the warranty form.

If changes are made to the crane by anyone other than a Hoeflon International B.V. employee, the warranty will be void.

No warranty is given on the following parts:

- Imitation parts or parts that were not ordered from Hoeflon International.
- Labour charges for installation/repair of the compact crane.
- Parts that have become defective due to incorrect/improper use, overloading, lack of maintenance, incompetence, accidents, normal wear, etc.
- Parts required for scheduled maintenance.
- If a completed warranty form is not returned to Hoeflon International B.V.,
- Reimbursement will only be provided for the parts.

The full terms and conditions of the warranty are available from your dealer on request.

# 5

## SAFETY

---

### 5.1 Operating personnel

Operating personnel may not be under the influence of narcotics or alcohol and must be at least 18 years of age. These persons must be familiar with all the functions and tools associated with this hoisting and lifting tool. Persons who work with the compact crane must wear safety shoes, gloves and a safety helmet.

### 5.2 Warnings

Every employee must heed the following warnings/regulations.



**DANGER!**

Lifting with the boom below horizontal is prohibited, due to the extension and retraction chains. With the jib lower than horizontal is allowed.



**DANGER!**

Never allow unauthorised persons to come within the working range of the machine while it is in operation. Never swing a suspended load over people.



**DANGER!**

It is prohibited to lift loads with a damaged or weakened hook, cable or other lifting equipment.



**DANGER!**

Avoid contact with rotating parts.



**DANGER!**

It is prohibited to use the compact crane in the vicinity of high voltage cables!



**DANGER!**

Never climb on the machine when it is in motion or when it is being used.



**DANGER!**

It is prohibited to use the compact crane in an explosive environment.



**DANGER!**

Never transport the compact crane without first ensuring that the crane, outriggers and ballast are fully collapsed, retracted and locked, and there is no load on the crane; otherwise there

is a risk of dangerous situations and possible damage to the machine!



**DANGER!**

Make sure the load bearing capacity of the ground is adequate; use access mats or outrigger pads. Caution: never on manholes or beside/in holes.



**DANGER!**

It is prohibited to use the compact crane to transport or lift persons.



**DANGER!**

It is prohibited to use the compact crane to pull loads free, cause them to fall, push them or pull them at an angle.



**DANGER!**

It is prohibited to bypass a sensor; doing so can cause danger to life and damage to the machine. Contact Hoeflon International B.V. immediately in the event of a defective sensor.



**DANGER!**

It is prohibited to change the pressure settings and the motor/engine speed; this can lead to dangerous situations and damage to the machine and immediately voids the warranty.



**DANGER!**

Never lift heavier loads than the maximum permitted working load according to the table.



**DANGER!**

Never leave the compact crane unattended with a load hanging from the machine.



**DANGER!**

Only move loads that can move freely from the surface they are sitting on and that are located directly beneath the hook!



**DANGER!**

Remove the keys from the ignition switch when operating the crane; prevent unauthorised persons from switching the machine on or off.



**DANGER!**

Do not raise the boom more than 60° if the outrigger legs on the **ballast side** are positioned parallel (180°) to the compact crane! Otherwise the compact crane may tip over.



**DANGER!**

It is prohibited to raise the jib beyond 70°.



**DANGER!**

Never place materials or tools on the engine shroud of the machine or on the crane. These parts can be knocked off by the engine or fall off of the machine.



**DANGER!**

It is prohibited to use the compact crane in stormy weather and/or in wind speeds in excess of Beaufort Force 6.



**WARNING!**

Only suitable, trained persons who are familiar with the content of this user manual and have completed the user training provided by Hoeflon International B.V. may operate or work with the compact crane!



**WARNING!**

Dangerous situations can arise in which there is intense interaction between the machine, the operator, the load, the

surroundings and the ground. Thorough knowledge and preparation is a must.



**WARNING!**

It is not advisable to use the electric drive system in rain, snow, or high or wet grass or to drive through water.



**WARNING!**

It is prohibited to drive the compact crane on public roads; the compact crane is not equipped with the markings and lights required to do so.



**WARNING!**

Hot parts of the engine and components of the hydraulic system can cause burn injuries.



**WARNING!**

When disconnecting hydraulic lines and hoses, precautionary measures must be taken to ensure that the line/hose is no longer under pressure once the supply of energy to the system has been switched off.



**WARNING!**

Ensure that the outrigger legs are not extended too far to prevent contact between the ballast and outrigger legs during slewing.



**WARNING!**

Avoid contact with the outrigger legs when setting or retracting the outriggers (crushing danger).



**WARNING!**

Never transport a loaded compact crane.



**WARNING!**

Always collapse the crane after use in case of possible windy conditions when not in use.



**CAUTION!**

Mind the height restriction in covered areas.



**CAUTION!**

When working in a poorly lit environment, artificial light must be used to ensure that operations involving the compact crane can be performed safely.



**CAUTION!**

Make sure there are no loose parts present on the boom during lifting operations.



**CAUTION!**

The boom is flexible and bends when lifting the load. Be aware that when the load is released the boom will bend back.



**CAUTION!**

The lifting point on top of the jib is only intended for lifting the loose jib; it is forbidden to use it to lift a load or lash the machine in place.



**CAUTION!**

Take extra caution and safety measures in situations where the ground, the surroundings or the load strongly influences or restricts the use of the machine. When in doubt about the safe use of the machine, get advice from a specialist or contact your dealer or the manufacturer.

**CAUTION!**

Maintain a close watch on the active outrigger leg during extension to prevent foot entrapment.

**CAUTION!**

The compact crane may only be moved by means of hold-to-run control. Always maintain a good view of the surrounding area, to avoid hitting people or objects.

**TIP**

*Use communication equipment if the operator does not have a complete overview of the working area of the compact crane.*

**TIP**

*Never leave a machine unattended with the keys and remote control.*

**TIP**

*Keep the compact crane clean and prevent accumulation of contamination.*

**TIP**

*Follow national regulations concerning working conditions and work safety when using the compact crane.*

**TIP**

*It is recommended that the outriggers be positioned 10 cm above the ground and alongside the machine when driving on a soft or inclined surface to prevent tipping over.*

**TIP**

*It is not possible to fold in the jib when the boom is raised above 45 degrees.*

## 5.3 Emergency stop

An emergency stop is present on the electrical cabinet and the remote control. Emergency stop buttons all have the same function: when activated they stop all movements. Only operate the emergency stop in the event of an emergency or disaster.

## 5.4 Emergency control

**WARNING!**

Extra caution is required when using the emergency control, because the display screen on the remote control no longer works.

- Only use the emergency control if the remote control cannot make radio contact, the display screen is defective or there is no replacement battery available.
- When the emergency control cable is connected, the display screen no longer works!
- Connect the emergency control cable to the connection on the underside of the transmitter and on the electrical cabinet (see figures 4 and 5).
- Operate the transmitter in the usual way, as described in section 6.2.1.



Figure 4: Emergency control







Figure 5: Emergency control









Figure 6: Emergency control

## 5.5 Pictograms

The pictograms used are shown below. These may not be removed. Missing or damaged pictograms must be replaced immediately!

Pictogram	Meaning	Location
	Use of safety shoes, gloves and safety helmet is mandatory.	On electrical cabinet
	Lifting point for lifting the machine.	On boom
	L to R: Do not use in the vicinity of high voltage cables; Suspended load; It is prohibited to be under the load.	On the crane
	It is prohibited for unauthorised persons to be within the working range or DANGER ZONE of the machine.	On the cover of the electrical cabinet
	Check that all safety devices are installed correctly before starting up the machine.	On the cover of the electrical cabinet

Pictogram	Meaning	Location
	Always consult the user manual before taking any action.	On the cover of the electrical cabinet
	Attention: Raising and lowering outriggers.	On the outriggers
	Attention: When the green lamp is on, the radio remote control for the crane is active.	On crane column next to warning light
	Risk of cutting or severing	On the crane at pivot points and on the outrigger legs at the cylinders
	Electrical danger	On electrical cabinet
	Risk of trapping hands.	On the ballast
	Warning for radio remote control.	On superstructure electrical cabinet

## 5.6 Signal column

A signal column is fitted on the compact crane. The meaning of the colours is shown below. When bypassed by means of the key switch, the signal column produces an audible signal to warn everyone in the vicinity.

				Crane operation active
				Driving
				Load at 90% to 100%
				Load at 100%
				Bypass 100% to 110%
				Bypass without protection



Figure 7: Signal column

# 6

## WORKING WITH THE COMPACT CRANE

Every employee must observe the following rules/warnings while working with the compact crane.



**DANGER!**

Never enter the working area; this can have serious consequences.



**DANGER!**

Do not let unauthorised persons enter the working area of the compact crane.



**DANGER!**

It is prohibited to use the compact crane in an explosive environment!



**DANGER!**

The user is responsible for safe operation of the crane, the selection of appropriate accessories (based on intended use, capacity, validity of inspection stickers and visual inspection) and the personal safety of the operator and people in the vicinity.



**DANGER!**

Outriggers may only be used on a suitable surface. This means adequately level and with sufficient load bearing capacity.



**WARNING!**

Work safely at all times, taking into account the crane, surroundings, ground and load. Do not begin working if there is a plausible risk of a dangerous situation developing before appropriate measures have been taken.



**WARNING!**

Operate the compact crane carefully; to prevent jolts while driving, never release the levers suddenly. May only be operated by authorised persons!



**WARNING!**

When bypasses are placed in the electrical cabinet (*figure 26 no. 6*) sensors are bypassed. It is prohibited to bypass the winch sensor. If you place a bypass, you do so entirely at your own risk.

**WARNING!**

Always perform the daily inspection first!

**WARNING!**

Always ensure that no hazardous situation can develop!

**WARNING!**

Ensure that the compact crane working area is tidy and cordoned off.

**WARNING!**

Use an extension cable with a diameter of at least 2.5 mm<sup>2</sup> and measuring no more than 25 m in length.

**CAUTION!**

Do not use the compact crane until precautions have been considered and taken to safeguard the user, the machine, the load, the surroundings and the ground.

**CAUTION!**

Ensure proper extraction of the exhaust gases when used in enclosed areas.

**CAUTION!**

When it is necessary to perform other related work, switch off the control to prevent unintentional movements.

**CAUTION!**

Never leave the control unattended, unless the ignition key is removed.

**CAUTION!**

Never place loose parts on moving components of the compact crane.

**TIP**

*The directions of movement of the remote control with respect to the compact crane match best if you are behind the compact crane.*

**TIP**

*Use the toolbox only for crane parts and the tools necessary for working with the compact crane (if present).*

## 6.1 Daily inspection prior to use



**DANGER!**

The engine must be stopped when topping off oil, coolant or fuel; DO NOT smoke while performing these tasks.

For your own safety and to obtain the maximum service life from your equipment, it is of great importance that you always inspect the condition of the compact crane before use. Resolve any problems you find, or have your dealer do so, before you use the compact crane again.

- Before performing the daily inspection, first ensure that the compact crane is horizontal (to ensure proper oil levels).
- Check that the engine is switched off.
- Perform a thorough general visual inspection of the compact crane. Look, in particular for oil and/or coolant leaks, leaking cylinders, loose connections, dirt accumulation and any damage. Remove any dirt which has accumulated and have necessary repairs performed if you observe a leak.
- Check the engine oil level **before starting** and top up if necessary. Running the engine while the oil level is too low can result in engine damage.
- The oil level of the Yanmar engine must be between (2) and (3) on the dipstick (1). Pull the dipstick out of the engine and wipe it off. Now insert it completely again and then remove it and read the level. Top up if low. Unscrew cap (4) and fill through (5). (See figure 8)
- Check the oil level in the hydraulic tank: top up with Hydro 32 if necessary (see figure 9).
- Check that all protective caps and covers are in position and that all nuts and bolts are in place and secured firmly.
- Make sure that the locking pins are present and secure. For example, at the outrigger leg, jib and lifting accessories.
- Check the fuel level, top up if necessary with diesel fuel EN 590 (see figure 10).
- See section 7.5 for the diesel fuel specifications.
- Check the coolant level in the Yanmar engine. When the engine is warm the level should be at the full line and, when cold at the low line (see figure 11).
- Top up with coolant if necessary (see section 7.5 for coolant specifications).

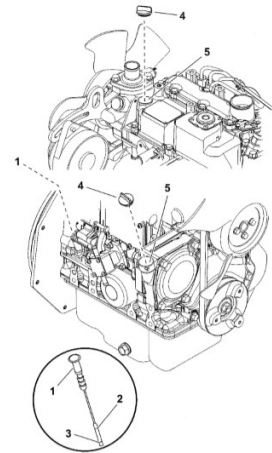

Figure: 8



Figure: 9



Figure: 10



Figure: 11

- Do not under any circumstances remove the cap while the engine is warm! (see figure 12).

*If there is still coolant in the expansion tank, just fill it to the proper level (figure 11). Otherwise also top up the radiator Figure: 11*

- If there is still coolant in the expansion tank, just fill it to the proper level (figure 11). Otherwise also top up the radiator completely (figure 12).
- If present, remove the air cleaner cover and inspect the air filter elements. Clean or replace contaminated air filter elements. Always replace damaged air filter elements.



Figure: 12

- Visually inspect the tension and condition of the crawler tracks. If defects are found, contact the dealer.
- Raise the machine on the outriggers. When the crawler tracks are raised above the ground they may not sag more than 2 cm at the bottom. If they hang too low they must be tightened.
- To tighten the crawler tracks, place the grease gun on the grease nipple in the middle of the crawler tracks and pump until the grease gun becomes more difficult to pump. The crawler tracks must be firmly tensioned.
- Check if the sensors for the boom and jib pulse on/off when the extend function is operated. This is how the boom length is measured.
- Check that the crane control levers return to the centre position automatically and that the outrigger controls are automatically locked.
- Make sure that all loose parts are correctly stored/secured.
- Check that the emergency stop button functions correctly; never perform lifting operations if the emergency stop button is not functioning properly. If defective, always have this repaired immediately!
- Check for wear of the winch cable, hook and other lifting accessories.



Figure: 13

## 6.2 Controls

### 6.2.1 Remote control

The compact crane is operated by remote control; the buttons and functions of the remote control are explained in this section.

- The transmitter is splash and rain-proof.
- Never clean the transmitter and receiver with high pressure and do not immerse them.
- Keep transmitter clean; ensure that pictograms, screen and labels remain legible.
- Wear the transmitter on the waist belt around your waist or over the shoulder with a shoulder strap.
- Always keep a second, fully charged transmitter battery at the ready.
- If the transmitter has poor or no contact, switch off the transmitter and the ignition switch of the machine. Switch on again and the transmitter automatically seeks a new frequency.



Figure: 14

Levers in standard Default						
Number	Lever	Key switch in position 1		Key switch in position 2		
		Backwards	Forwards	Lever	Backwards	Forwards
1	LF outrigger	Up	Down	Slewing	Left	Right
2	LR outrigger	Up	Down	Main boom	Retract	Extend
3	L track	Backwards	Forwards	Jib	Retract	Extend
4	R track	Backwards	Forwards	Winch	Raise	Lower
5	RR outrigger	Up	Down	Jib	Extend	Retract
6	RF outrigger	Up	Down	Main boom	Extend	Retract



Figure: 15

Buttons			
	Emergency stop	17	Display
	On/off button transmitter		Engage second operating speed
	Activate receiver and horn		Control panel display: ✓ Confirmation button ▲ Up arrow button ► Right arrow button ▼ Down arrow button ◄ Left arrow button ↶ Back button
	Has no function on the C10		Has no function on the C10
	Boost crane capacity to 110% for 30 seconds		Has no function on the C10
	On/off button electric motor		Key switch in position 1 = extend crawler tracks Key switch in position 2 = extend ballast
	Has no function on the C10		Key switch in position 1 = retract crawler tracks Key switch in position 2 = retract ballast
	On/off button Yanmar diesel engine		Work light (optional)
	Preheat button Yanmar diesel engine		Has no function on the C10
	Crane/drive selector (only with pick-and-carry option)		

## 6.2.2 Function mapping

This function allows you to assign different functions to the levers. As standard, it is set to **default**. If you set it to **custom**, then it is set the same as many lorry loader cranes.

- Switch on the remote control and activate the remote control menu by pressing the ✓ button (see figure 16).

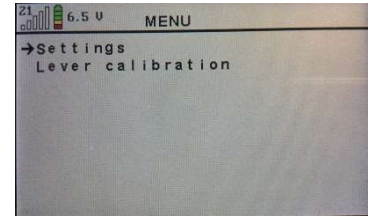

Figure: 16

- Then open **settings** by pressing the ✓ button and use the ▼ button to go to **function mapping** (see figure 17).

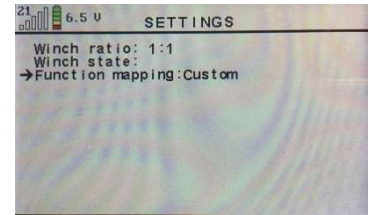

Figure: 17

- Then press the (▶) button to set the **custom** function (see figure 17).

The table below shows the new functions of the levers.

Levers in standard Default						
Number	Lever	Key switch in position 1		Key switch in position 2		
		Backwards	Forwards	Lever	Backwards	Forwards
1	LF outrigger	Up	Down	Slewing	Left	Right
2	LR outrigger	Up	Down	Main boom	Retract	Extend
3	L track	Backwards	Forwards	Jib	Retract	Extend
4	R track	Backwards	Forwards	Winch	Raise	Lower
5	RR outrigger	Up	Down	Jib	Extend	Retract
6	RF outrigger	Up	Down	Main boom	Extend	Retract

### 6.2.3 Calibrate levers

If the levers do not respond over the entire range of movement, they must be calibrated. This is done as follows:

- Switch on the remote control and activate the remote control menu by pressing the ( ✓ ) button (see figure 18).
- Press the ( ▼ ) button to move the arrow in the display until it points to **Lever calibration** (see figure 22).

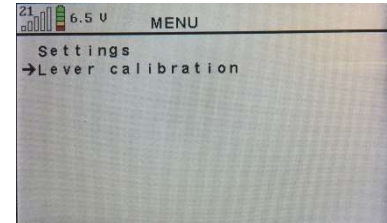

Figure: 18

- Press the ( ✓ ) button and you will be taken to the **Calibrate levers** screen. You see a bar for each lever.
- When you operate a lever the bar turns green. In the maximum position the bar must be 100% green. If not, the levers must be calibrated (see figure 19).

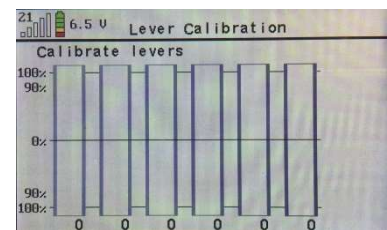

Figure: 19

- Press the ( ✓ ) button and you will be taken to the next screen. It says **Put levers in center**. Leave all the levers in their middle position; do not operate them (see figure 20).

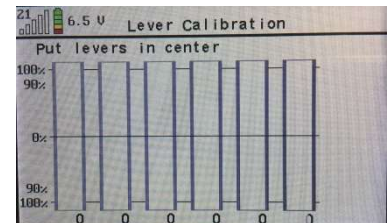

Figure: 20

- Press the ( ✓ ) button and you will be taken to the next screen. It says **Move levers back and forth**. Slowly operate the levers one at a time, from the maximum backwards position to the maximum forwards position (see figure 21).

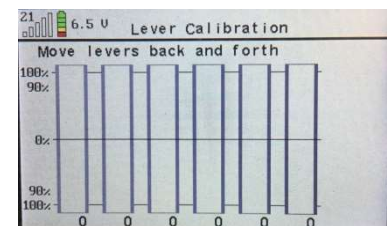

Figure: 21

- Press the ( ✓ ) button and you will be taken to the next screen. It says **Save calibration**. If you now operate a lever, the bar will turn green again in the direction you have chosen. At the maximum forwards or backwards position, the green bar will fill to 100%. If everything is working properly, press the ( ✓ ) button and the settings will be saved (see figure 22).

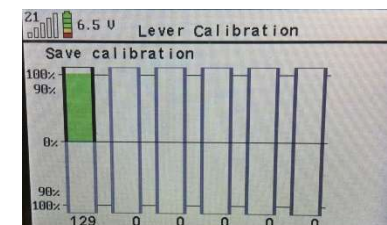

Figure: 22

- Now press ( ↶ ) twice and you will return to the home screen.

### 6.2.4 Changing the transmitter battery

To change the battery in the transmitter, proceed as follows:

- Switch off the transmitter and the machine.
- Remove the battery from the transmitter (figure 23).
- Swap the battery in the transmitter with the battery in the battery charger on the crane column (see figures 24 and 25). The battery on the crane column will be charged again when the crane is used. Attention! There is a half circle in the plastic on the battery and another on the battery socket. Make sure these are aligned with each other. Otherwise the battery will be backwards.
- The machine can be started again.
- See table below for meaning of the LEDs.



Figure: 23



Figure: 24



Figure: 25

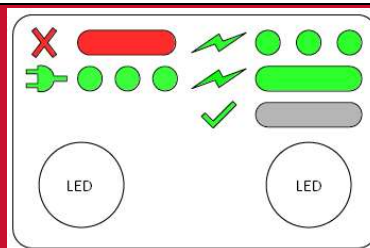

Left LED Battery charger status, for troubleshooting only		Right LED Battery status, for user	
LED status	Meaning	LED status	Meaning
Short green every 5 s	12V connected	LED off	Battery not connected
LED continuous red	Malfunction	LED continuous green	Battery charging 1A
		LED flashing green	Charging 0.3A
		LED off	Battery fully charged

### 6.2.5 Electrical cabinet



**DANGER!**

Remove the keys from the key switch when during work on the electrical system to prevent unauthorised persons from switching the machine on.



**DANGER!**

Remove the keys from the key switch when operating the crane to prevent unauthorised persons from switching the machine on or off. Attention! When bypass is active at no. 6 the sensors are bypassed. If the sensor on the winch cylinder is bypassed, the winch motor will continue to run when the winch cable reaches the stop; consequently the winch cable may be pulled apart.

There are a number of functions present on the electrical cabinet. These functions are shown and explained below.



Figure: 26

Electrical cabinet		
Number	Component	Function
1	Main switch (implemented as key switch).	<b>Left (0):</b> Machine switched off. <b>Centre (1):</b> In this position the drive system and outriggers are active. <b>Right (2):</b> In this position the crane can be operated.
2	Emergency stop	Switches drive system off.
3	'Power on' indicator	Lit when key switch is on.
4	Mains power indicator	Lit when mains power is correctly connected.
5	Connection for emergency control cable	-
6	Key switch	Centre: neutral Right: complete bypass of control functions
7	Main circuit breaker	400 V
8	Blade-type fuses	15A PCBs, controller 15A battery charger and sensors 25A engine

## 6.3 Crane functions/operation



**DANGER!**

Stay clear of the ballast, particularly during retraction of the ballast (risk of crushing).



**TIP**

Make sure that the crane and the track undercarriage are parallel to one another before collapsing the crane!



**TIP**

In the event of an overload, retract the extendable sections of the crane or lower the winch cable until the load is once more within the safe operating range of the crane.

### 6.3.1 Order of operations

To operate the arm of the compact crane, follow these steps in sequence:

- Start the engine and activate the transmitter as described in section 6.46.4.
- Check that the outriggers are extended and that the compact crane is level (see section 6.5).
- Check the gauge for the winch cylinder. Points on the plate must be between the points on the boom (see yellow circle in figure 27). **Contact the dealer or Hoeflon International B.V. if the gauge goes outside this range as a result of incorrect lifting capacity.**
- Turn the key switch on the electrical cabinet to the 'crane' position.
- The Yanmar engine has a standard speed. Or, if fitted with the 'actuator' option, the engine speed is automatically increased when a function is operated.
- Before extending the ballast make sure the ballast will not contact the boom.
- Slide the ballast out completely by pressing this  button on the transmitter. Attention! A dangerous situation can arise if the ballast is not completely extended, because the outrigger legs will be hit during slewing.
- Swing both ballast sections to the rear (see figure 28).
- Secure the ballast in place with the retainer (see figure 29).
- Erect the crane by raising the cylinders of boom 1 and the jib in succession, using the corresponding levers on the transmitter (see section 6.2.1). The boom and jib can then be extended. Collapse the crane by performing this procedure in reverse order.

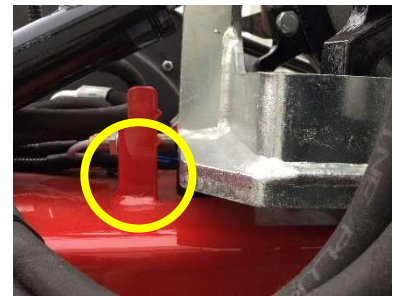

Figure: 27



Figure: 28



Figure: 29

### 6.3.2 Operation

- Operate the crane with the remote control by moving the levers (see section 6.2.1).
- Do not operate more than one crane function at a time.
- An overload warning will be displayed if the crane reaches its maximum upper position. Lower the mast slightly.

### 6.3.3 Guiding the load



**WARNING!**

The mass, centre of gravity and permissible lift points of the load must be known. The proper crane configuration and lifting accessories can be determined accordingly.



**WARNING!**

Always operate the machine with great care and only in the first operating speed. Avoid abrupt movements and maintain contact with any assistants helping to guide the load.

Adhere to the following rules when guiding a load:

- Never place body parts (feet, legs, hands) under the load.
- During horizontal guiding of the load, follow behind the load.
- Never place body parts between the load and obstacles in the surrounding area, and never go between the load and an obstacle without a safe amount of space between them.
- When working near or with fragile material (e.g. stone, glass) where there is a risk of splinters/shards, wear protective clothing and safety glasses.
- Maintain visual contact and open channels of communication between guides and operator.
- When working with tall, unstable loads, never stand in the fall direction of the load.
- Whenever possible, use guide lines to maintain a safe distance.
- When using guide lines for a load at height, never walk under the load and maintain a safe distance, taking into account influence of the fall direction of the load due to obstacles in the environment.
- Make sure you always have an open escape route where you can flee for safety.
- Never stand or hang on the load.
- Make sure the load is properly secured and is and will continue to hang stable.
- Avoid abrupt movements of the machine and load.
- Only operate the machine in the slow operating speed.
- When using guide lines, clear the surrounding areas to eliminate the risk of tripping and the risk that the guide line will get caught and/or damaged.

## 6.4 Driving the compact crane



**DANGER!**

On slopes:

Maximum slope angle

Forwards

24°

Backwards

28°

Sideways

Retracted tracks: 15°

Extended tracks: 23°



**DANGER!**

It is forbidden to be beside the compact crane while driving. This is due to the risk of instability.



**WARNING!**

Operate the compact crane carefully; to prevent jolts while driving, never release the levers suddenly. May only be operated by authorised persons!



**WARNING!**

It is forbidden to drive through water more than 20 cm deep.



**WARNING!**

Always drive with the tracks extended; this minimises the load on the ground and provides the machine with maximum stability.



**WARNING!**

If the situation necessitates that the tracks be retracted, always use the first driving speed. Be extra cautious.



**WARNING!**

It is forbidden to pull with boom and jib, both horizontally and vertically, such as pulling out poles or dragging loads. The crane is intended for vertical transport of loads subjected only to the pull of gravity.

Dragging loads from the pulling eye is allowed while driving.

### 6.4.1 Sequence of operations for starting crane





- Ensure that all control levers are in the 0/middle position.
- Ensure that the crane is collapsed and unloaded.
- Turn the key switch on the electrical cabinet to the 'outriggers/driving' position (1) (see *figure 26*).
- Switch on the transmitter (*figure 14*) with button 
- Press the 'activate receiver' (*figure 14*) button  on the transmitter; the receiver is now activated.
- Start the Yanmar engine as follows:
  - After preheating, start the Yanmar engine from the transmitter (see *figure 14*) by pressing button 
- Start the electric motor as follows:
  - Connect a power cable to the socket provided for this purpose (see *figure 30*).
  - Switch off the electric motor from the remote control (see *figure 14*) by pressing button 
  - Use a power cable with a cross-sectional area of at least 2.5 mm<sup>2</sup> and for optimal use a cable with a maximum length of 25 m.
- Operate levers 3 and 4 on the transmitter at the same time to drive in the direction indicated by the arrow and operate just one lever to steer.
- The driving direction is indicated by an arrow on the crawler track undercarriage (see *figure 31*).
- The Yanmar engine has a fixed speed, unless fitted with the 'actuator' option, in which case the speed is temporarily increased when a crane function is operated.
- Stop the compact crane by releasing the levers; they return to the centre position automatically.
- Stop the Yanmar engine from the transmitter (see *figure 14*) by pressing button 



Figure: 30



Figure: 31

## 6.4.2 Setting track width





### WARNING!

Make sure the compact crane is standing on the outriggers so that the crawler tracks are able to move freely.



### WARNING!

Avoid contact with the outrigger legs due to risk of entrapment!

- First raise the crane on the outriggers.
- Press button  to set the crawler tracks wider or button  to set the crawler tracks narrower (see figure 14).
- Only set the crawler tracks to the maximum or minimum width.

## 6.4.3 Transport position

The compact crane must be put in the transport position for driving. To do this, follow these steps:

- Be careful when lowering the boom to the transport position that the boom and jib do not contact the engine shroud and toolbox at the front and that the jib does not contact the toolbox if the jib is hanging beside the boom.
- The jib adapter can be attached to the jib if the jib is hanging beside the boom and other attachments are desired.
- Secure attachments in the intended locations during transport: 30° section and winch head beside the boom, manual jib extension on the right side of the column, jib adapter in the boom.
- Make sure that in the transport position the winch is always rolled up and the attachments are stowed and secured.

## 6.5 Setting the outriggers



**WARNING!**

To prevent contact between the ballast and outrigger legs during slewing make sure that the outrigger legs are not extended too far, e.g. one outrigger placed on an elevation.



**WARNING!**

Ensure that the outrigger leg is horizontal, with a maximum deviation of 5°, to prevent instability.



**WARNING!**

Do not raise the compact crane higher on the outriggers than necessary; once the tracks have been lifted off the ground it is high enough.



**WARNING!**

Assess the ground condition and use outrigger pads to reduce the ground pressure.



**CAUTION!**

Make sure the outrigger foot sits in the recessed circle on the outrigger pad when setting the outriggers. This is particularly important when raising the machine high on the outriggers, in connection with the folding legs.



**CAUTION!**

Check that the crane is retracted.

### 6.5.1 Order of operations



**DANGER!**

Outriggers may only be used on a suitable surface. This means adequately level and with sufficient load bearing capacity.



**WARNING!**

Maintain a close watch on the active outrigger leg during extension to prevent foot entrapment.

#### Preparation

- Make sure the ground has sufficient load bearing capacity.
- Position the machine in the ideal location; consider safety, obstacles in slewing range, outreach of the load and capacity and limits of the crane and ground.
- If the crane is raised on the outriggers in the vicinity of a ditch or slope, it is recommended that distance A from the outrigger to the edge be at least twice as long as depth B of the ditch (see figure 40).
- Make sure that people who must be within the working area of the crane can work there safely, by giving them instructions and showing them safe escape routes.
- To operate the outriggers, the boom angle must be less than 40 degrees and the ballast must be retracted.

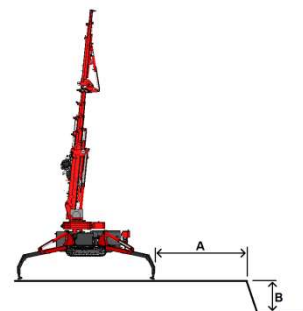

Figure: 40

### Step-for-step

- Switch on the machine with the key switch of the machine in position 1, for the drive and outrigger functions.
- Switch on and activate the remote control.
- Set the outrigger angle of each outrigger leg, preferably to 45 degrees for 100% outrigger leg range.
- Check the outrigger angle on the display of the remote control.
- Operate the outriggers one at a time and lower them until they are horizontal so the outriggers can be more easily extended. Maintain a clear view of the operated outrigger.
- Set the outrigger length by fully extending the outriggers.
- Check the outrigger length on the display of the remote control.
- Operate the outriggers one at a time and lower the outrigger legs until they are just above the ground. Maintain a clear view of the operated outrigger.
- Place the outrigger pads under the outrigger feet so the outrigger foot falls in the recess of the outrigger pad. Also check the ground in the immediate vicinity for unevenness, loose material, slope and other issues that can affect the stability.
- Operate the outrigger legs one at a time and lower them onto the outrigger pads.
- Now operate the outriggers at the front simultaneously so the machine is just lifted off the ground; do the same with the rear outrigger legs.
- Check whether the machine is level and correct if necessary. The bubble in the spirit level must be in the centre of the circle (see figure 32).
- Check whether all the outriggers are in contact with the ground and correct if necessary.
- Turn the key switch to position 2 once the machine is standing firmly on the outriggers; the outrigger configuration is now set and is saved.

### Check

- Check the outrigger angle and length on the remote control display.
- Check the levelling of the crane (see figure 32) crane after setting the outriggers.
- Make sure all the legs are in firm contact with the ground.



Figure: 32

## 6.5.2 Operation

### Mechanical

- Release the outrigger legs by operating the lever, so the outriggers can be swung manually (see figure 33).
- Turn the outrigger legs so that they are positioned at a 45° angle to the machine and then release the lever. The lever will spring back to its released position automatically when it is in the correct position.
- Turn the key switch (1) on the electrical cabinet to the 'outrigger operation/driving' position.

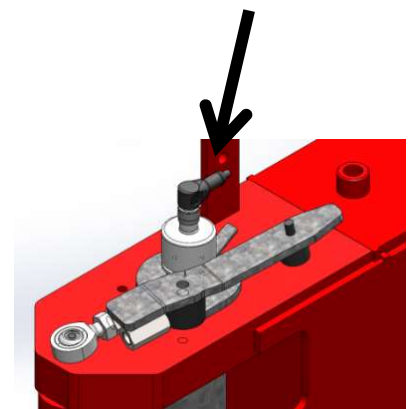

Figure: 33

Figure: 34

- Activate the transmitter and start the drive system.
- Extend the outriggers of the compact crane until the outrigger legs are horizontal by pushing forward levers 1, 2, 5 and 6 on the transmitter one at a time.
- Remove the pin from the extendable section (see figure 34), pull the extendable section out to the white stripe (see figure 35) and lock it in place.



Figure: 34

- Position the four outrigger legs of the compact crane so that the outriggers are level, using rig mats or outrigger pads.

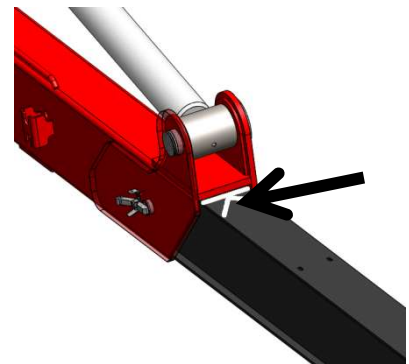

Figure: 35



Figure: 36

### 6.5.3 Interpreting the display while setting the outriggers

While the outriggers are being set, info about how much may be lifted and how the crane is positioned is shown on the display of the remote control. This is explained below.

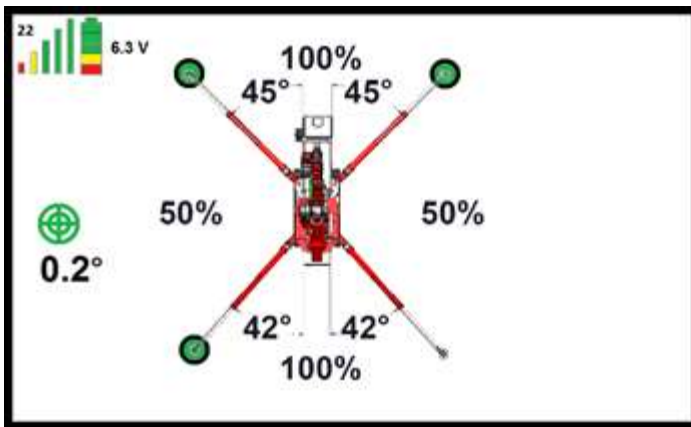

Figure: 37

- The transmission frequency is shown at the top left. See figure 37; here it is set to 22.
- The signal strength is indicated by 5 vertical bars. If the strength is good, they are all shown, as in figure 37. As the signal weakens, the green bars disappear first, then the yellow and red ones. If the signal is too weak, you can select a different frequency by switching off the transmitter and machine and switching them on again. See section 6.2.1.
- The battery state of charge is shown in the battery symbol in the top-left corner of the screen. When the battery is fully charged, 3 green blocks, 1 yellow and 1 red are shown, as in figure 37. As the battery discharges, the blocks go out, one at a time.
- The voltage is shown in volts. In figure 37 this is 6.3 V.
- The degree of levelling of the machine is also shown. This is indicated by the green circles in the middle. In figure 37 the crane is 0.2° out of level. Which side it is leaning towards is not shown. This can be seen on the level (see figure 32).
- The left-front outrigger leg is set at 45° in figure 37.
- The right-front outrigger leg is set at 45° in figure 37.
- The left-rear outrigger leg is set at 42° in figure 37.
- The right-rear outrigger leg is set at 42° in figure 37.
- At the front of the crane 100% of the lifting capacity may be lifted in figure 37.
- On the right side of the crane 50% of the lifting capacity may be lifted in figure 37.
- At the rear of the crane 100% of the lifting capacity may be lifted in figure 37.
- On the left side of the crane 50% of the lifting capacity may be lifted in figure 37.
- A green circle is shown by three of the four outrigger legs in figure 37. The outrigger leg without a circle is not set properly; this outrigger leg is probably not in contact with the ground. When a green circle appears, it is set properly.

## 6.6 Attachment/Removal

### 6.6.1 Jib

Removing the jib:

- Position the boom and jib as shown in figure 38. Make sure the boom is positioned slightly above horizontal. This makes the jib easier to turn.
- Remove the two pins from the left-hand side of the hinged section of the jib (see figure 39).
- Rotate the jib 180° (see figure 40).
- Secure the D-shackle on the main boom to the eye on the jib (figure 41). Raise the jib when you do this, until it can be secured in the D-shackle. Secure the D-shackle (see figure 42).
- The jib is now suspended in the D-shackle and can be moved easily.
- Remove the two pins from the right-hand side of the hinged section of the jib. Lower the jib when you do this so that it is easier to remove the pins.



Figure: 38



Figure: 39



Figure: 40



Figure: 41



Figure: 42

- Use the shaft on the underside of the boom to guide the jib into the appropriate section of the main boom (figure 43) and secure it in position (figure 44).



Figure: 43



Figure: 44

- Secure the lever on the hook on the jib and lock it into place (figure 45)



Figure: 45

- Disconnect the hydraulic hoses (figure 46) and the power plug (figure 47). Secure the loose hoses to the jib.



Figure: 46



Figure: 47

- The fixed section of the jib can be removed from the main boom, if necessary, by removing the pin (figure 48) and manually pulling the section out of the main boom (figure 49). It is also possible to work with the compact crane if the fixed section of the jib is still in the boom.



Figure: 48

- To install the jib, perform the steps in reverse order.
- Do not forget to secure the pins!



Figure: 49

## 6.7 Function/operation winch



**DANGER!**

Max. winch load is 1000 kg, 2000 kg with single reeving and 4000 kg with double reeving. When a reeved cable is used, it is prohibited to lift if the winch cables are twisted.



**DANGER!**

Make sure the cable runs through the grooves in the cable sheaves and the slot in the winch head stop plate!



**DANGER!**

Make sure the winch cable does not have any damage, cracks, wear, twists or bends. If it does, replace the cable before using the crane.



**WARNING!**

The winch may only be used for vertical lifting; if lifted at an angle there is a risk of overload.



**WARNING!**

When a reeved cable is used, it is prohibited to lift if the winch cables are twisted. Make sure the cable runs through the grooves in the cable sheaves and the slot in the winch head stop plate!



**WARNING!**

As far as possible, leave the winch weight on the cable so that it will roll up tighter.



**WARNING!**

The winch will stop automatically when there are 3 rotations of steel cable remaining on the winch drum.

- For the proper selection of attachments and rotation angles, refer to the tables in sections 6.7.3 to 6.7.6. Any other use is prohibited.
- Reeve the winch cable if the mass of the load exceeds the capacity of the winch. For single reeving (two cables) use one disc in the winch weight, and for double reeving (four cables) use two discs in the winch weight. For reeving, see section 6.7.7.
- The winch cable may get stuck under the ballast tube with the boom at 85 degrees; this risk can be eliminated by extending the ballast.
- Make sure both pins are attached and secured when using the winch head in the 30° section.
- Push the winch weight backwards when lifting the winch weight off of the engine shroud bracket. Be careful that the winch weight does not get caught on the support.
- When removing the winch weight be careful that the elastic strap that holds the lifting hook has been removed.
- When configuring the winch weight for reeving, be sure to remove the centring bush for the lifting hook when switching from two discs to one disc, or to no discs. It should only be used when two sheaves are used in the winch weight.
- Any time tension has been removed from the winch cable, check that the winch cable is still taught and neatly wound around the winch drum before operating the winch.
- When using the winch, keep in mind the limits of the various machine configurations.
- Remember: the complete winch weight is 33 kg. It is not intended to be lifted or moved by hand.
- With the exception of the winch weight and ballast removal bracket, never pull on parts of the machine.

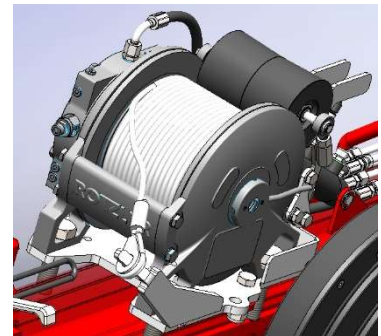

Figure: 50

## 6.7.1 Order of operations without options

### Check

- Check that the winch plate is within the indicator range. The winch plate must not be crooked. When under tension, the winch plate must be between the indicator points (see *figure 51*).
- Check the cylinder behind the winch for leakage.  
Visually inspect the winch cable for external defects, such as bends, broken strands, rust formation and wear.
- Check whether the winch cable is wrapped neatly and tightly on the drum; if not, unroll it and roll it up tightly (see *figure 52*).

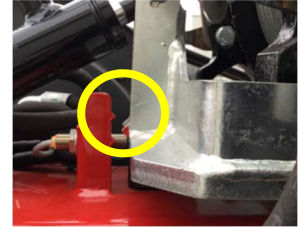

Figure: 51



Figure: 52

### Preparation

- Make sure the machine is supported on the outriggers, with the tracks just above the ground.
- Make sure the jib, jib adapter and/or other attachments have been removed from the boom and stored and secured in place.
- Make sure the boom is horizontal and retracted.

### Attachment of winch head

- Remove the winch head from the bracket on the boom. Fit the retainers again after removal (see *figure 53*).



Figure: 53

- Secure the boom adapter to the rear of the winch head with the locking pin. Secure the pin (see *figure 54*).



Figure: 54

- Connect the winch head with the boom adapter to the boom with the locking pin. Secure the pin (see figure 55).

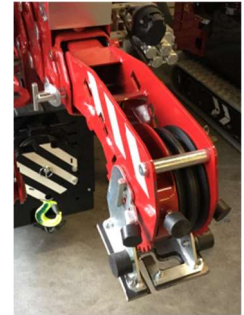

Figure: 55

**Activating winch operation**

- Activate the winch control by pressing the ✓ button on the remote control (see figure 56).

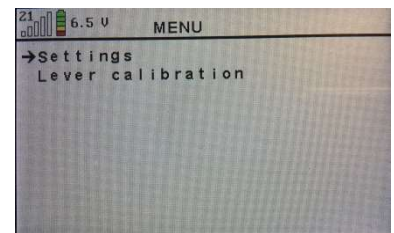

Figure: 56

- Then open settings by pressing the ✓ button. Now move the arrow on the screen to winch state with the ⏪ button. Then press the ⏩ button to set the Winch state to Enabled (see figure 57).

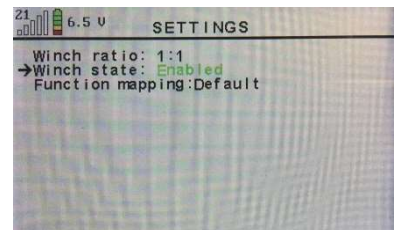

Figure: 57

- For the correct current load indication on the display while using the winch, the **winch state** must be set properly. For standard lifting with a single cable this should be set to 1:1. It should be set to 1:2 for single reeving and 1:4 for double reeving (see figure 58).
- After activating and setting the winch, return to the main display by pressing the ⏪ button.

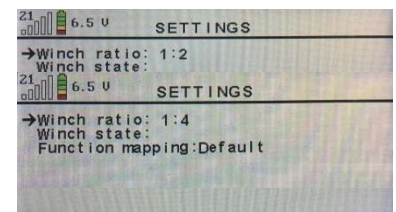

Figure: 58

**Step-for-step**

- Activate the transmitter as described in section 6.4 and start the drive system.
- Check that the outriggers are extended and that the compact crane is level (see section 6.5).
- Check whether the winch plate is between the indicator points. **If not, contact your dealer or Hoeflon International B.V.**
- Turn the key switch on the electrical cabinet to the 'crane' position (see figure 26).
- Erect the crane by raising the cylinders of boom 1 and the jib in succession, using the corresponding levers on the transmitter (see section 6.2.1). Then the boom and jib can be extended. Roll out the winch cable as described below.

## Fitting winch cable



### WARNING!

The use of gloves is mandatory when attaching the winch cable!

- Use one hand to operate the joystick for the winch and use the other hand to hold the winch cable and keep it under tension.
- Roll out the winch cable until approximately one metre in front of the machine. Keep the winch cable under tension while rolling it out.
- Switch the crane off.
- Run the winch cable over the winch cable sheaves of the boom as shown in the figures. Check that the winch cable has been run over the winch sheaves correctly (see figure 60). There is an arrow engraved in the side of each winch sheave. These indicate how the cable is to be routed.
- Run the winch cable over the winch head. First remove the upper pin in the winch head. For lifting with one cable, place the winch cable over the centre winch cable sheave and fit and secure the upper pin in place again. Position the cable correctly through the winch weight stopper (see figures 61 and 62).



Figure: 60



Figure: 61



Figure: 62

## Rolling up winch cable

- When rolling up the winch cable after you are finished using the winch, roll up the winch cable until approximately one metre in front of the machine, then guide it off of the winch cable sheaves, then pull the cable taught and roll it up (see figure 63).
- Hang the eye around the support and carefully roll up the winch cable and gently pull it tight.

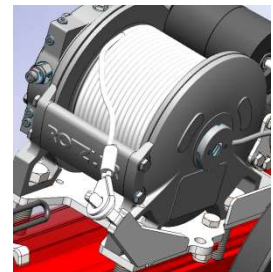

Figure: 63

- Deactivate the winch by setting the **Winch state** to **Disabled** in the remote control menu (see figure 64).
- 
- 

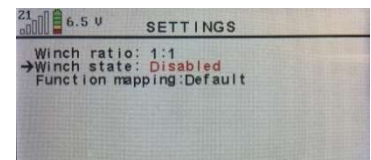

Figure: 64

## 6.7.2 Order of operations for use with jib

### Preparation

- Make sure the machine is supported on the outriggers, with the tracks just above the ground.
- Make sure the jib is correctly attached to the boom, as described for use of the jib (see section 6.6.1).
- Make sure the attachments have been removed from the jib and stored and secured in place.
- Make sure the boom and jib are horizontal and retracted,

### Mounting winch head and attaching winch cable

- Remove the winch head from the support on the boom, and mount the winch head to the jib with the locking pin. Secure the pin.
- Use one hand to operate the joystick for the winch and use the other hand to hold the winch cable and keep it under tension. Roll out the winch cable until approximately one metre in front of the machine. Keep the winch cable under tension while rolling it out.
- Run the winch cable over the winch cable sheaves of the jib as shown in the figures. Check that the winch cable has been run over the winch sheaves correctly. Fit the retainers again.
- Run the winch cable over the winch head and attach the winch weight as described under 'basic use of winch' (see section 6.7.1).

### Check

- Make sure all the pins and loose parts are properly attached and secured.
- Make sure the winch cable does not get caught on the boom and jib structure.

When the jib installed:

- Slide the cable through the opening between the two cable rollers (see figure 65). Now release the cable between the two rollers. Insert the eye through the recessed support. Now place the cable in the cable roller by holding the cable in the upper notch and sliding the roller under it. Now the cable can drop into the roller, and the roller with cable can be slid back into the middle.
- Pass the cable through the plastic slot so that it runs through the hole (see figure 66).



Figure: 65



Figure: 66

- Pull the cable over the winch head (see figure 67) and follow the steps described above.
- To remove the winch cable, perform the steps in reverse order. Make sure that the winch cable is rolled tightly by holding the cable firmly while rolling.



Figure: 67

- After removing the winch, connect a hook to a D-shackle if required (*see figure 68*). Insert pin and lock in position.
- For operation of crane and winch, see sections 6.2, 6.3, 6.5 and 6.7.



Figure: 68

### 6.7.3 Order of operations winch head and manual jib extension plus additional 30 degree adjustable section

#### Preparation

- Make sure the machine is supported on the outriggers, with the tracks just above the ground.
- Make sure the jib is correctly attached to the boom, as described for use of the jib.
- Make sure the attachments have been removed from the boom or jib and stored and secured in place.
- Make sure the boom and/or jib are horizontal and retracted,

#### Attaching 30° adjustable section

- Remove the 30° adjustable section from the boom; fit the retainer back in place. If it will be used in the boom, mount the boom adapter.
- Mount the 30° adjustable section to the boom or jib and lock it with the locking pin. Secure the pin.
- Attach the manual jib extension to the 30° section with the two pins and secure them.

#### Attaching manual jib extension

- Remove the manual jib extension (figure 69) from the ballast weight.
- Place the manual jib extension in the jib tube and lock it with the pin.
- Or place the boom adapter so the manual jib extension can be placed directly in the boom and lock it with the locking pin.
- 

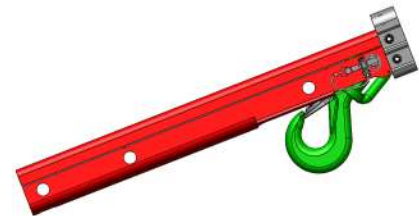
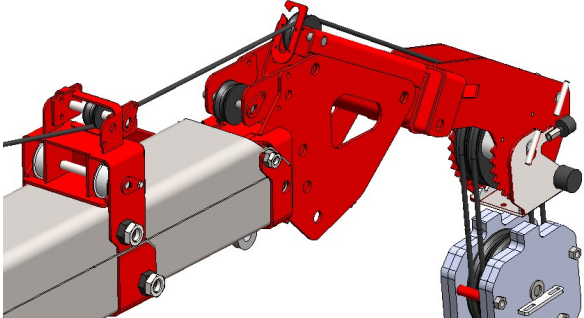
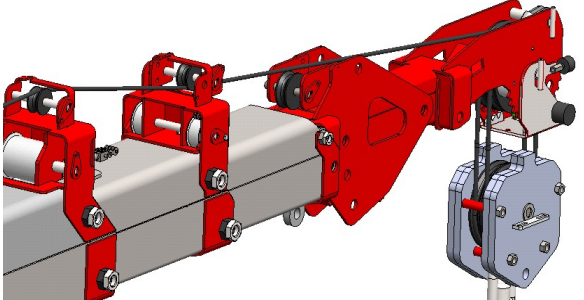
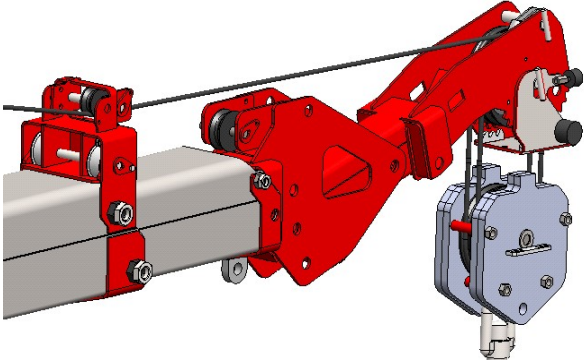
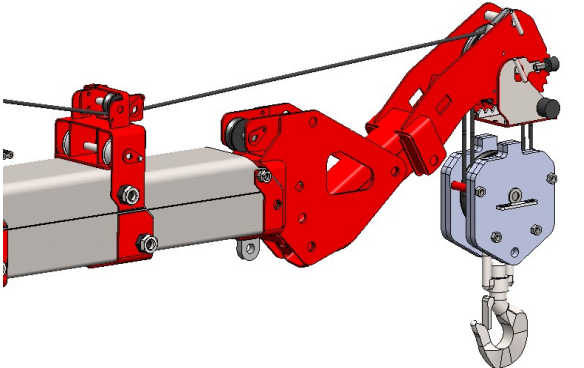

Figure: 69

#### Attaching manual jib extension along with 30 degree adjustable section

- Remove the 30° adjustable section from the boom; fit the retainer back in place. If it will be used in the boom, mount the boom adapter.
- Mount the 30° adjustable section to the boom or jib and lock it with the locking pin. Secure the pin.
- Attach the manual jib extension to the 30° section with the two pins and secure them.

**6.7.4 Positions of winch head in 30° section when used with main boom**

Main boom	
<p>Winch head in top hole. See the adjacent figure for the cable routing. Cable over auxiliary pulley to rear of winch head.</p>	
<p>Winch head in 2<sup>nd</sup> hole. See the adjacent figure for the cable routing. Cable without auxiliary pulley to large cable sheave in winch head.</p>	
<p>Winch head in 3<sup>rd</sup> hole. See the adjacent figure for the cable routing. Cable without auxiliary pulley to large cable sheave in winch head.</p>	
<p>Winch head in bottom hole. See the adjacent figure for the cable routing. Cable without auxiliary pulley to large cable sheave in winch head.</p>	

### 6.7.5 Positions of winch head in 30° section when used with jib

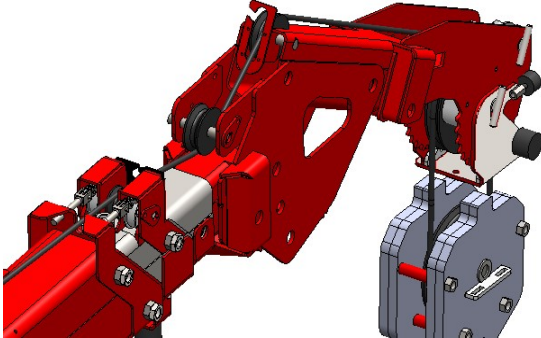
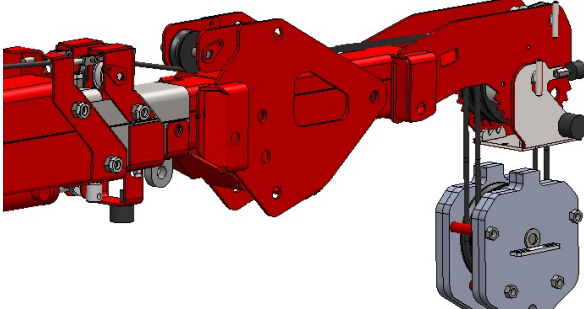
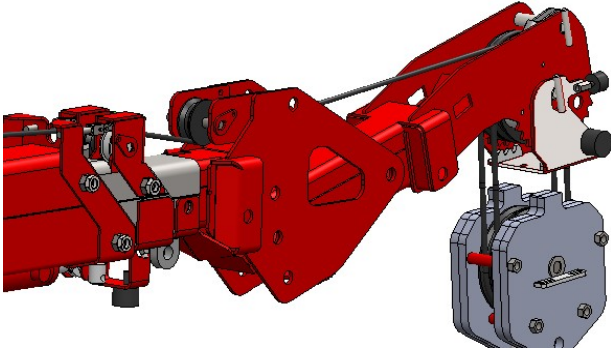
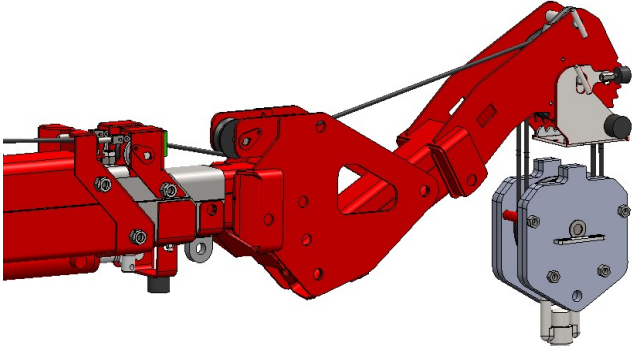
Jib	
<p>Winch head in top hole.</p> <p>See the adjacent figure for the cable routing.</p> <p>Cable under auxiliary pulley of the 30° section and over auxiliary pulley at rear of winch head, to large cable sheave in winch head.</p>	
<p>Winch head in 2<sup>nd</sup> hole.</p> <p>See the adjacent figure for the cable routing.</p> <p>Cable under auxiliary pulley of the 30° section through to large cable sheave in winch head.</p>	
<p>Winch head in 3<sup>rd</sup> hole.</p> <p>See the adjacent figure for the cable routing.</p> <p>Cable under auxiliary pulley of the 30° section through to large cable sheave in winch head.</p>	
<p>Winch head in bottom hole.</p> <p>See the adjacent figure for the cable routing.</p> <p>Cable under auxiliary pulley of the 30° section through to large cable sheave in winch head.</p>	

**6.7.6 Limits**

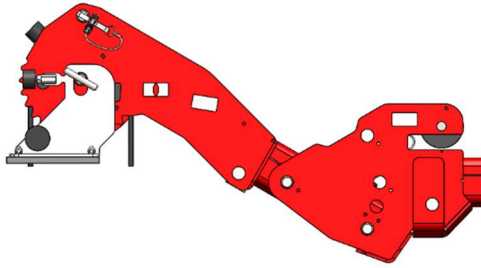

Figure 70: 30 degree adjustable section raised

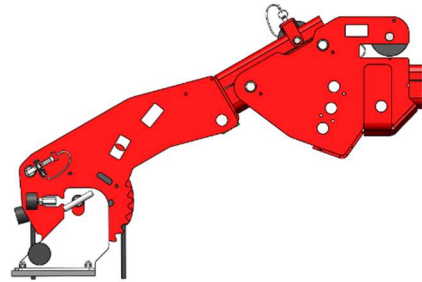
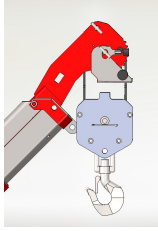
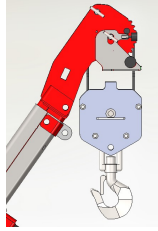
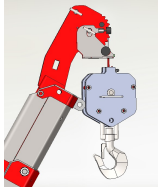
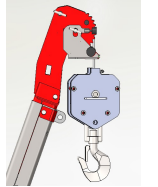
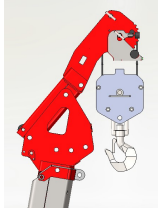
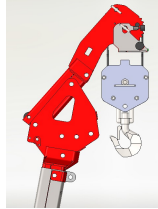
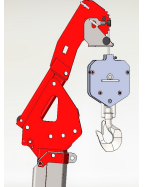



Figure 71: 30 degree adjustable section lowered

	Number of reevings	USE WITHOUT JIB		USE WITH JIB	
		Min. boom angle	Max. boom angle	Min. jib angle	Max. jib angle
Winch head without lifting weight					
Winch head	0	0 degrees	70 degrees	-70 degrees	70 degrees
	1 or 2	0 degrees	45 degrees	-70 degrees	45 degrees
30° adjustable section with winch head facing down (see Figur 71).	0	0 degrees	85 degrees	-40 degrees	70 degrees
	1 or 2	0 degrees,	85 degrees, 80 degrees with retracted boom	-70 degrees	60 degrees
30° adjustable section with winch head facing up (see Figur 70).	0	0 degrees	60 degrees	-70 degrees	60 degrees
	1 or 2	0 degrees	35 degrees	-70 degrees	35 degrees

Maximum angles

Winch head positions	Maximum possible angle of main boom from horizontal	Illustrations main boom max. position	Maximum possible angle of jib from horizontal	Illustrations jib max. position
Winch head with lifting weight reeved	≤ 45°		≤ 55°	
Winch head with lifting weight and single cable	≤ 60°		≤ 70°	
Winch head with 30° section in upper hole with lifting weight reeved	≤ 80°		≤ 80°	
Winch head with 30° section in upper hole with lifting weight and single cable	≤ 85°		≤ 85°	

### 6.7.7 Attachment winch weight



**DANGER!**

Max. winch load is 1000 kg, 2000 kg with single reeving and 4000 kg with double reeving. When a reeved cable is used, it is prohibited to lift if the winch cables are twisted.



**DANGER!**

Make sure the cable runs through the grooves in the cable sheaves and the slot in the winch head stop plate!



**WARNING!**

The winch will stop automatically when there are 3 rotations of steel cable remaining on the winch drum.

#### Preparation

- Make sure the machine is supported on the outriggers, with the tracks just above the ground.
- Make sure the winch head is mounted as described (see section 6.7.1).

#### Attaching winch weight without reeving

- Remove the split pin from the winch weight.
- Take off the front half of the winch weight.
- Remove the two cable sheaves.
- Remove the lifting hook with the centring bush.
- Refit the lifting hook without the centring bush.
- Attach the winch cable eye to the shaft on which the cable sheaves were fitted.
- Fit the front half of the winch weight back in position. Note: the front half must be turned around before it is put in place again. It will now slide the rest of the way over the strips, and the eye of the winch cable will fit nicely in between.
- Fit the split pin in the 2nd hole in front of the front section of the winch weight so it is secured in place.
- Set the winch ratio to 1:1 on the remote control.

#### Attaching winch weight with single reeving

- Remove the split pin from the winch weight.
- Take off the front half of the winch weight.
- Remove one cable sheave.
- Remove the lifting hook with the centring bush.
- Refit the lifting hook without the centring bush.
- Attach the winch cable to the cable roller.
- Fit the front half of the winch weight back in position. Note: the front half must be turned around before it is put in place again. It will now slide the rest of the way over the strips and almost contact the cable roller.
- Fit the split pin in the 2nd hole in front of the front section of the winch weight so it is secured in place.
- Pull the cable eye of the winch cable along the inside of the winch head and place it over the black plastic with the hole in it. Remove the pin at the top of the winch head and fit it again with the pin through the cable eye.
- Set the winch ratio to 1:2 on the remote control.

#### Attaching winch weight with double reeving

- Remove the split pin from the winch weight.
- Take off the front half of the winch weight.

- Lead the winch cable around one cable sheave and then around the outermost cable roller of the winch head. Then around the 2nd cable roller of the lifting weight.
- Make sure the lifting hook is around the centring bush.
- Fit the front half of the winch weight back in position. Make sure it is placed such that the cable rollers can turn freely. If it is mounted incorrectly, the cable sheaves will rub against the steel weight.
- Fit the split pin in the 1st hole in front of the front section of the winch weight so it is secured in place.
- Pull the cable eye of the winch cable along the inside of the winch head and place it over the black plastic with the hole in it. Remove the pin at the top of the winch head and fit it again with the pin through the cable eye.
- Set the winch ratio to 1:4 on the remote control.

### Check

- Make sure all the pins and loose parts are properly attached and secured.
- Make sure the winch cable does not get caught on the boom and jib structure.

### Step-for-step

- Switch on the remote control and position the winch cable above the winch weight by raising the boom, slewing it if necessary and rolling out the winch cable. Use one hand to operate the joystick for the winch and use the other hand to hold the winch cable and keep it under tension.
- Remove the pin from the removable half of the winch weight and remove this half (*see figure 72*).



Figure: 72

- Fit the required number of cable sheaves. For no reeving do not use any sheaves. Attach the eye to the shaft that the sheaves were on (*see figure 73*).



Figure: 73

- Position the lifting hook and the winch cable, fit the removable half of the winch weight back in place and secure it in place (*see figure 73*).

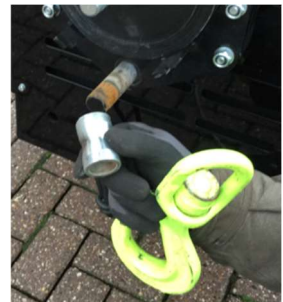
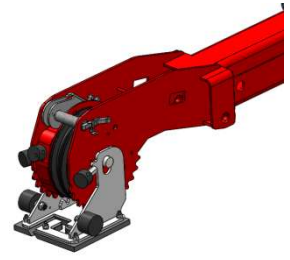

Figure: 73

- During reeving attach the loop of the winch cable to the winch head. The cable must enter the hole in the plastic from the inside of the winch head, and then the pin can go through the eye of the winch cable. Secure the pin (*see figure 75*).

- Use one hand to operate the joystick for the winch and use the other hand to hold the winch cable and keep it under tension. Pull the winch cable until it is under tension.
- Use one hand to push the winch weight backwards so it is no longer secured and use the other hand to operate the joystick for the winch. See whether the winch weight can be lifted free of the support, and lift the winch weight off of the support.



*Figure: 75*

### 6.7.8 Explanation of display during lifting

While working with the crane, if the crane is set to crane operation, the following information is shown on the remote control display. The values that appear on the display are explained below.

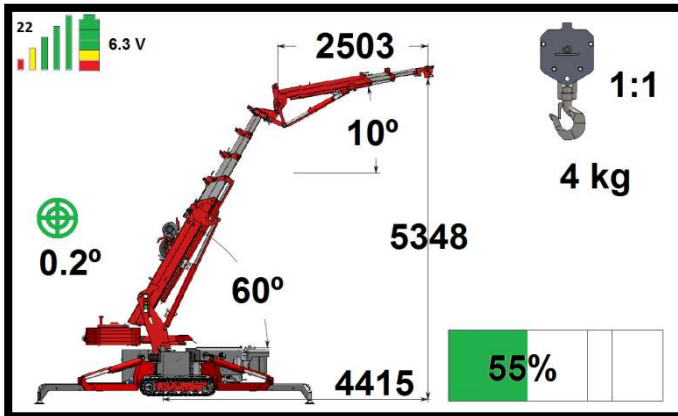

Figure: 76

- The transmission frequency is shown at the top left. See figure 76; here it is set to 22.
- The signal strength is indicated by 5 vertical bars. If the strength is good, they are all shown, as in figure 76. As the signal weakens, the green bars disappear first, then the yellow and red ones.
- The battery state of charge is shown in the battery symbol in the top-left corner of the screen. When the battery is fully charged, 3 green blocks, 1 yellow and 1 red are shown, as in figure 76. As the battery discharges, the blocks go out, one at a time.
- The voltage is shown in volts. In figure 76 this is 6.3 V.
- The degree of levelling of the machine is also shown. This is indicated by the green circles in the middle. In figure 76 the crane is 0.2° out of level. Which side it is leaning towards is not shown. This can be seen on the level (see figure 32).
- The position of the main mast is 60° in figure 76.
- The position of the jib is 10° in figure 76.
- The radius of the outreach is 4415 mm in figure 76.
- The lifting height is 5348 mm in (figure 76).
- The length of the jib is 2503 mm in figure 76.
- The reeving is 1:1, so one cable is being used for lifting.
- There is 4 kg in the lifting hook.
- The crane is loaded at 55% in figure 76.
- As can be seen in figure 76, the ballast is extended. When the ballast is retracted it moves on the display, and when the ballast is removed from the crane it is no longer shown on the display.

# 7

## MAINTENANCE/ TROUBLESHOOTING

### 7.1 General



**DANGER!**

Remove the key from the key switch before performing work on the compact crane.



**DANGER!**

Never use your hand to locate a leak in the hydraulic system; use a piece of paper or cardboard instead. Oil under high pressure can penetrate the skin and cause poisoning.



**DANGER!**

When topping off oil, coolant or fuel, shut off the engine. Smoking during these operations is prohibited.



**DANGER!**

Always correctly reinstall any protection measures that have been removed!



**WARNING!**

Only the dealer or Hoeflon International may perform work on the electrical or hydraulic system of the machine.



**WARNING!**

Attention! Engine parts may be hot. Allow them to cool first!



**CAUTION!**

Consult the dealer

The maintenance instructions are presented in this chapter. Proper maintenance is the key to keeping the machine operating properly. It is very important that these instructions are followed, to ensure your safety and that of others who are present.

Unusual noises or vibrations can indicate a defect in the machine. It is then necessary to perform a repair or maintenance without delay. Consult your dealer about this.

Contact your dealer's technical department for additional information concerning aspects such as maintenance and repair of specific machine parts.

## 7.2 Maintenance work

The risk of accidents with machines is generally greater during maintenance, cleaning and service. Have maintenance of the compact crane performed by the dealer. In the Netherlands you can choose to enter a maintenance contract with Hoeflon International B.V.

### Weekly maintenance

- See maintenance chart.
- Grease the compact crane in accordance with the lubrication chart.
- Clean the compact crane with water and a mild cleanser such as car wash shampoo. Never use solvents or other flammable liquids as a cleanser. Never direct the nozzle of a pressure washer directly at the engine/motor or electrical parts.
- Clean the machine daily after use in or transport through a salty/briny environment. Be sure to remove all the salt/brine, to prevent corrosion of the machine.

### Monthly maintenance

- See maintenance chart.
- Grease the compact crane in accordance with the lubrication chart.

### Scheduled service

- The first scheduled service must be performed after 2 weeks or 50 hours of operation.
- Thereafter the compact crane requires scheduled service annually or every 250 hours of operation.
- It must also be inspected annually.
- It is recommended that you have the scheduled service and inspections performed by your dealer or Hoeflon International B.V.

### First use

- Perform the daily inspection. (see section 6.1).
- Test the following aspects of the compact crane:
  - Operation of emergency stop.
  - All functions work properly.
  - Safety provisions work properly.

## 7.3 Maintenance schedule

Description of maintenance	Action	Interval in hours ( o = manufacturer/dealer, ● = owner )							
		daily	First 50 hours	Every 50 hours	Every 100 hours	Every 250 hours	Every 500 hours	Every 1000 hours	Every 4000 hours
<b>Yanmar engine</b>									
Engine oil	Check level	●							
	Replace		o			o			
Air filter	Inspect			●					
	Clean			●					
	Replace						o		
Engine oil filter	Replace		o			o			
Water separator filter	Clean			●					
Idle speed	Check/adjust							o	
Valve clearance	Check/adjust							o	
Fuel filter	Replace					o			
Fuel hoses	Inspect						o		
Injectors	Test							o	
Radiator	Clean			●					
V-belt	Inspect			●					
	Replace						o		
Coolant	Check/top up	●							
	Replace							o	
<b>Crawler track undercarriage</b>									
Tension of crawler tracks	Check/adjust			●					
Oil level track motors	Check/top up					o			
	Replace						o		
<b>General</b>									
Machine	Clean			●					
Safety devices	Inspect	●							
Lifting accessories (cables, hooks, etc.)	Check/replace	●							
Control levers	Inspect	●							
Condition and presence of pictograms	Inspect					o			
Mechanical components	Inspect	●							
Boom clearance	Check/adjust							o	
Turntable	Check/tighten		o				o		
	Lubricate			●					
Construction incl. pins, shafts, etc.	Inspect					o			
Boom extension and retraction chains	Inspect				●				
	Lubricate				●				
Plastic slide plates on boom	Inspect					o			
	Lubricate			●					
Boom guide bolts	Inspect					o			
Pivot points and extendable sections	Lubricate			●					
Bolt connections	Tighten						o		
Boom wear parts (completely disassemble)	Replace							o	
<b>Hydraulic system</b>									
Hydraulic oil	Inspect	●							
	Replace							o	
Leaks	Inspect	●							
Hydraulic hoses	Inspect					o			
	Replace							o	
Pressure levels	Inspect						o		
Hydraulic return filter	Replace		o				o		
Hydraulic pressure filter	Replace						o		
Stop valves and pressure relief valve	Test							o	
Hydraulic system	Flush							o	
<b>Electrical system</b>									
Wiring connectors	Inspect					o			
Emergency stop and sensors	Inspect	●							
Voltage	Inspect					o			

## 7.4 Lubrication chart

- Lubricate the compact crane as shown in the lubrication chart below, paying particular attention to the following:
- Clean the grease nipples thoroughly before lubrication.
- Remove excess/old grease from the masts.
- Use clean greases, stored in sealed packaging.
- Lubricate the top side of the plastic guide on the boom by inserting a grease gun fitted with a spot nozzle through the holes, when the boom is fully extended.
- **Use only prescribed greases; see lubricant specifications.**

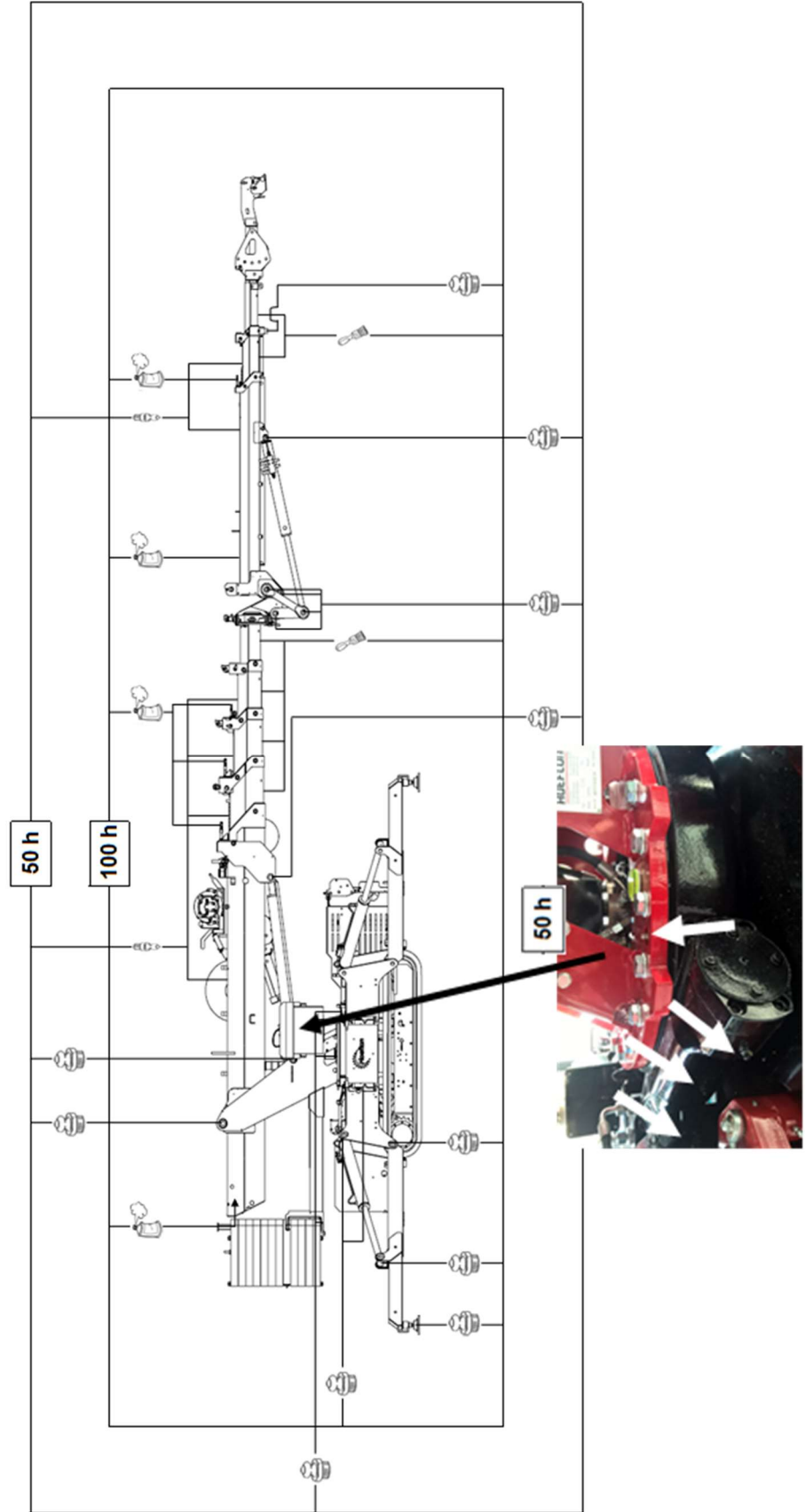

## 7.5 Lubricant specifications

Manu- facturer:	Engine oil	Coolant	Hydraulic oil		Final drives	Lubri- cation points	Chains	Sliding sections	
			Universal	Bio				Lubri- cating grease	Spray
<b>Q8</b>	Q8 Formula Advanced SAE 10W-40	Q8 Antifreeze Long Life G12	Heller 32	Q8 Holbein HP SE Bio 46	T 55	EP 2	Industrial chain spray	EP2	PTFE
<b>Total</b>	Total Quartz 7000 Diesel SAE 10W-40	Auto Supra	Equavis AF 32 / ZS 46	BioHydran TMP 32	EP-B 80W90	EP 2	Industrial chain spray	EP2	PTFE
<b>Shell</b>	Shell Helix Plus 10W-40	G12	Shell Tellus S2/S3	Shell Naturelle HF-E 32	Spirax S3 AX 80W-90	EP 2	Industrial chain spray	EP2	PTFE
<b>Kroon oil</b>	Emperol 10W-40	Coolant SP 12	Perlus ZF 46	Perlus Biosynth 46	Gearlube GL-5 80W- 90	EP 2	Industrial chain spray	EP2	PTFE

The diesel fuel used in the Yanmar engine must meet the following specifications.

- The cetane number must be 45 or higher.
- Use clean fuel.
- The diesel may not be more than 7% bio diesel.

Diesel fuel specifications	Location
ASTM D975 No. 1D S15 No. 2D S15	USA
EN 590:96	European Union
ISO 8217 DMX	International
BS 2869-A1 or A2	United Kingdom
JIS K2204 Grade No.2	Japan
KSM-2610	Korea
GB252	China

### 7.5.1 Boom extension and retraction chains

- Do not repair chains or insert links; if deficient, completely replace.
- If there are two extension or retraction chains, replace both, along with the connections, at the same time.
- If the chains are soiled to the point that lubrication no longer helps, clean with petroleum ether or diesel. Do not clean with acidic agents or a high pressure hose. These can damage the chains.
- Check the chain regularly for lubrication, rust, breaks in the pins/plates and wear and tear.
- Lubricate the chain every 100 hours (see maintenance schedule).

## 7.6 Use of start assistance terminals

### 7.6.1 Preparation

- Obtain a start assistance source with the correct voltage and sufficient capacity that is fit for purpose and place it as close as possible to the machine, yet at a safe distance.
- Obtain suitable start assistance cables with sufficient length and thickness and intact insulation, fitted with good, preferably insulated clamps.
- Make sure the area is safe, without any water or conductive materials. Make sure there are no loose parts on the machine or that may fall on the machine.
- Place insulating material to prevent indirect contact with the + terminal (behind red protective cap) and chassis.
- Remove the remote control battery from the charger on the machine to prevent damage.

### 7.6.2 Procedure

- Make sure the machine and the start assistance source are switched off.
- Place insulating material between the chassis and + start assistance terminal, if necessary.
- Make sure the start assistance cables are connected to the start assistance source correctly.
- Always hold the + start assistance cable in your hand, prevent contact and do not place it near the – start assistance cable clamp.
- Prevent the start assistance cables from becoming twisted together; separate them from each other.
- First connect the + start assistance cable by clamping it firmly to the + start assistance terminal (with the red protective cap). Ensure that the clamp cannot contact the chassis or the – start assistance terminal (*see figure 77*).
- Connect the – start assistance cable.
- Verify that the clamps are correctly attached and making good contact.



Figure: 77

- Turn on the key switch on the machine, activate the control and, preferably, switch on an electrical consumer, such as the work lights.
- Switch on the start assistance source and allow the machine to charge for a few minutes.
- Preheat the diesel engine and start the machine. Avoid excessively long cranking.
- Switch off the start assistance source and remove the start assistance cables in the reverse order.
- Place the protective caps back on the start assistance terminals. Replace them if they are damaged.

## 7.7 Battery charger

- There is a battery charger mounted on the compact crane as standard equipment. This battery charger charges the compact crane's battery whenever the crane is run from 400V instead of the Yanmar engine.
- When the power cable (see figure 30, section 6.4.1) is connected the battery charger will switch on directly. An orange LED is lit.
- The charger monitors the battery voltage to determine whether or not it requires charging. If the voltage is low, it will be topped up. When the battery has reached the correct voltage again, the charger will automatically stop charging. During charging a white LED is lit beside the battery symbol, with '12 V' above it. A number of charge LEDs will also be lit. See table.







Figure: 78

LED	explanation
<p>25%</p> <p>Red LED</p> <p>25% 50% 75% 100%</p>	<p>The 25% charging LED flashes slowly when the battery has less than 25% of its charge remaining. When the battery is 25% charged, the red LED remains lit continuously.</p>
<p>50%</p> <p>Red LED</p> <p>25% 50% 75% 100%</p>	<p>The 50% charging LED flashes slowly when the battery has less than 50% of its charge remaining. When the battery is 50% charged, the red LED remains lit continuously.</p>
<p>75%</p> <p>Orange LED</p> <p>25% 50% 75% 100%</p>	<p>The 75% charging LED flashes slowly when the battery has less than 75% of its charge remaining. When the battery is 75% charged, the orange LED remains lit continuously.</p>
<p>100%</p> <p>Green LED</p> <p>25% 50% 75% 100%</p>	<p>The 100% charging LED flashes slowly when the battery has less than 100% of its charge remaining. When the battery is 100% charged, the green LED remains lit continuously and the 25%, 50% and 75% LEDs go out.</p>
<p>Green maintenance LED</p> <p>25% 50% 75% 100%</p>	<p>During maintenance charging the 100% LED flashes slowly. When the battery is 100% charged, the green 100% LED remains lit continuously.</p>

- The charger can provide a number of fault codes. The fault codes are indicated by the error LED (with the ! above it) and the stand-by LED (by the 'on' symbol). These light up or flash alternately. Information about the fault codes and possible solutions is provided in the table below.

<b>fault</b>	<b>Cause / solution</b>
Single flashes	Battery does not hold a charge. Have battery checked by your dealer.
Double flashes	Possible short-circuit in the battery. Have battery checked by your dealer.
Triple flashes	The battery voltage is too high for the selected charge mode. Check the battery and charge mode.
Continuously lit error LED	Reversed polarity. Swap the battery connections.
Continuously lit orange LED	The battery voltage is too low to detect the state of charge. Temporarily connect an extra battery to the machine via the start assistance terminals or contact your dealer.

## 7.8 Removing/installing ballast

	<p style="text-align: center;"><b>WARNING!</b></p>	<p>Removal support is only intended for removal of the ballast. For horizontal transport of the ballast, use two-way chain sling and attach to outrigger pad holders on top of ballast.</p>
	<p style="text-align: center;"><b>WARNING!</b></p>	<p>Store removal support after installing ballast</p>
	<p style="text-align: center;"><b>WARNING!</b></p>	<p>Never stand within the slewing range of the ballast. During extension, never stand within sliding range of the ballast (risk of crushing).</p>
	<p style="text-align: center;"><b>WARNING!</b></p>	<p>Be careful not to damage the machine while removing the ballast.</p>

### 7.8.1 Removing ballast

#### Preparation

- Make sure the machine is supported on the outriggers in a square configuration, with the tracks just above the ground and no load on the hook.
- Make sure there is enough room for the extended boom on one side, preferably the right side, so the ballast is removed on the left side (because the sensors are on the right side).
- Make sure the tracks are retracted.
- Make sure the boom is horizontal.
- Make sure the ballast is placed in a safe spot, not on walking or driving paths and not within the working range of the compact crane, other machines or workers.

#### Step-for-step

- First perform the daily inspection!
- Ensure that no hazardous situations can develop!
- Start the engine and activate the transmitter as described in the section DRIVING.
- Set the outriggers at 45°.
- Place a pallet next to the machine.
- Place the boom perpendicular to the machine with ballast to left of the machine and above the pallet.
- Set the boom horizontally.
- Remove the mounting bracket (see figure 79).
- Mount the ballast support on the boom (see figures 80 and 81).



Figure: 79



Figure: 80



Figure: 81

- Hydraulically extend the ballast (see figure 82).



Figure: 82

- Swing the ballast out manually (see figures 83 and 84).



Figure: 83



Figure: 84

- Mount the ballast support to the lifting points on the ballast elements with the D-shackles (see figure 85).



Figure: 85

- Remove the retainer clips from the shafts on both sides (see figure 86).

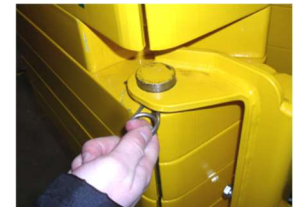

Figure: 86

- Attach the ballast elements together with the retainer (see figure 87).



Figure: 87

- Lower the boom slightly so the ballast just enters the removal support and is floating between the two tabs on which the ballast is mounted. Attention! Do not lower the boom too far or it may damage the removal support and the bracket to which the ballast is mounted.

- Remove both shafts from the ballast (see figure 88).



Figure: 88

- Hydraulically retract the ballast support. The ballast is now hanging loose, from the crane.
- Raise the boom.
- Lower the ballast onto the pallet (see figure 89).



Figure: 89

- Detach the D-shackles from the ballast and remove the ballast support from the boom.
- Put the ballast support back in its storage location on the engine shroud (see figure 90).
- The machine can now be put in the transport position and driven away from the ballast.
- Attach the ballast to the crane in the reverse order.



Figure: 90

### Verification

- Check whether the ballast has disappeared from the display on the remote control.
- Check whether the ballast is in a safe position, move if necessary and/or cordon off the area around the ballast to prevent accidents.

## 7.9 Troubleshooting



**DANGER!**

Remove the key from the key switch when performing work on the compact crane.



**DANGER!**

Never use your hand to locate a leak in the hydraulic system; use a piece of paper or cardboard instead. Oil under high pressure can penetrate the skin and cause poisoning.



**WARNING!**

Hydraulic oil can be hot; wear gloves and safety glasses when troubleshooting the hydraulic system.



**WARNING!**

When a leak has developed in the hydraulic system, not only repair the leak immediately but also top off the oil reservoir.



**WARNING!**

When disconnecting hydraulic lines and hoses, precautionary measures must be taken to ensure that the line/hose is no longer under pressure once the supply of energy to the system has been switched off. This can be achieved by moving the control levers back and forth.



**CAUTION!**

Consult the dealer.

Correct operation and careful maintenance ensure that the compact crane will have a long life with fewer problems.

The warnings above must be heeded for all work performed in connection with a malfunction.

Many common malfunctions are listed hereafter. If a malfunction occurs that is not mentioned in this user manual, please contact your dealer or Hoeflon International B.V.

Malfunction	Cause	Solution
The compact crane is not working properly; it jerks.	Too little oil in the hydraulic system. Hesitation when operating lever on remote control.	Check the hydraulic oil level.
Vibrations in the crane.	Oil temperature too low.	Increase oil temperature by raising and lowering an outrigger leg.
Telescoping section does not extend or retract completely or slides with difficulty.	Guide not well lubricated.	Lubricate the guide.
The crane does not slew well.	Turntable not well lubricated. Damaged or worn turntable mechanism.	Lubricate the turntable. Overhaul the turntable mechanism

Malfunction	Cause	Solution
Some functions do not work.	Fault in electrical system. Fault in torque limiter.	Check sensors. Check emergency stop button. Reduce the load on the crane.
Too little force applied to winch cable.	Leaky winch cylinder.	Repair leak.
One function does not work.	Fault in electrical system; electric motor has failed.	Check fuses or emergency stop buttons; check 15A blade-type fuses and 16A circuit breaker in electrical cabinet.
Slow movement.	Oil filter contaminated. Hydraulic pump defective.	Clean oil filter. Replace hydraulic pump.
Combustion engine does not start.	Battery discharged.	Check whether the battery charger is indicating a fault code. Reset battery charger by disconnecting 230 V plug, waiting 10 sec. and plugging it in again.
Grinding noise during movements.	Pivot points not well lubricated.	Lubricate pivot points according to lubrication chart.

### 7.9.1 Fault codes

Fault code	Problem	Possible solution. If this does not work, contact Hoeflon.
E001	Problem in software.	Contact Hoeflon.
E002	Problem in software.	Contact Hoeflon.
E003	Problem in software.	Contact Hoeflon.
E004	Problem in software.	Contact Hoeflon.
E005	Problem in software.	Contact Hoeflon.
E006	Problem in software.	Contact Hoeflon.
E007	Problem in software.	Contact Hoeflon.
E008	Problem in software.	Contact Hoeflon.
E009	Problem in software.	Contact Hoeflon.
E010	Problem in software.	Contact Hoeflon.
E011	Not used.	
E012	Not used.	
E013	Not used.	
E014	Not used.	
E015	Not used.	
E016	Not used.	
E017	Not used.	
E018	Not used.	
E019	Not used.	
E020	Not used.	
E021	Not used.	
E022	Not used.	
E023	Not used.	
E024	Not used.	
E025	Not used.	
E026	Not used.	
E027	Not used.	
E028	Crane is not properly supported by outriggers.	Set outriggers again.
E029	Not used.	
E030	Not used.	
E031	Not used.	
E032	Not used.	
E033	Not used.	
E034	Not used.	
E035	Not used.	
E036	Not used.	
E037	Not used.	
E038	Not used.	
E039	Not used.	
E040	Not used.	
E041	Not used.	
E042	Not used.	
E043	Not used.	
E044	Not used.	
E045	Not used.	
E046	Not used.	
E047	Not used.	
E048	Not used.	
E049	Not used.	
E050	Not used.	
E051	Not used.	
E052	Not used.	
E053	Not used.	
E054	Not used.	
E055	Not used.	
E056	Not used.	
E057	Not used.	
E058	Not used.	
E059	Problem with connection.	Contact Hoeflon or your dealer.
E060	Problem with connection.	Contact Hoeflon or your dealer.
E061	Problem with connection.	Contact Hoeflon or your dealer.
E062	Not used.	
Fault code	Problem	Possible solution. If this does not work, contact Hoeflon.
E063	Not used.	

E064	Not used.	
E065	Not used.	
E066	Problem with connection.	Switch machine off and on again.
E067	Problem with connection.	Switch machine off and on again.
E068	Not used.	
E069	Not used.	
E070	Problem with connection.	Switch machine off and on again.
E071	Problem with connection.	Switch machine off and on again.
E072	Not used.	
E073	Not used.	
E074	Problem with connection.	Switch machine off and on again.
E075	Problem with connection.	Switch machine off and on again.
E076	Not used.	
E077	Not used.	
E078	No contact with left-front angle sensor.	Switch machine off and on again.
E079	Incorrect value left-front angle sensor.	Switch machine off and on again.
E080	Incorrect value left-front angle sensor.	Switch machine off and on again.
E081	Problem left front.	Contact Hoeflon or your dealer.
E082	Problem left-front length sensor.	Activate the bypass and extend farther. The fault code disappears. Switch the bypass off.
E083	Problem left-front length sensor.	Activate the bypass and extend farther. The fault code disappears. Switch the bypass off.
E084	Not used.	
E085	No contact with right-front angle sensor.	Switch machine off and on again.
E086	Incorrect value right-front angle sensor.	Switch machine off and on again.
E087	Incorrect value right-front angle sensor.	Switch machine off and on again.
E088	Problem right front.	Contact Hoeflon or your dealer.
E089	Problem right-front length sensor.	Activate the bypass and extend farther. The fault code disappears. Switch the bypass off.
E090	Problem right-front length sensor.	Activate the bypass and extend farther. The fault code disappears. Switch the bypass off.
E091	Not used.	
E092	No contact with right-rear angle sensor.	Switch machine off and on again.
E093	Incorrect value right-rear angle sensor.	Switch machine off and on again.
E094	Incorrect value right-rear angle sensor.	Switch machine off and on again.
E095	Problem right front.	Contact Hoeflon or your dealer.
E096	Problem length sensor right rear.	Activate the bypass and extend farther. The fault code disappears. Switch the bypass off.
E097	Problem length sensor right rear.	Activate the bypass and extend farther. The fault code disappears. Switch the bypass off.
E098	Not used.	
E099	No contact with left-rear angle sensor.	Switch machine off and on again.
E100	Incorrect value left-rear angle sensor.	Switch machine off and on again.
E101	Incorrect value left-rear angle sensor.	Switch machine off and on again.
E102	Problem right front.	Contact Hoeflon or your dealer.
E103	Problem left-rear length sensor.	Activate the bypass and extend farther. The fault code disappears. Switch the bypass off.
E104	Problem left-rear length sensor.	Activate the bypass and extend farther. The fault code disappears. Switch the bypass off.
E105	Not used.	
E106	No contact with jib angle sensor.	Switch machine off and on again.
E107	Incorrect value jib angle sensor.	Switch machine off and on again.
E108	Incorrect value jib length sensor.	Activate the bypass and extend farther. The fault code disappears. Switch the bypass off.
E109	Not used.	
E110	No contact with boom angle sensor.	Switch machine off and on again.
E111	Incorrect value boom angle sensor.	Switch machine off and on again.
E112	Not used.	
E113	No contact with pressure sensor boom lift cylinder.	Switch machine off and on again.
E114	No contact with pressure sensor boom lift cylinder.	Switch machine off and on again.
E115	Not used.	
E116	No contact with housing angle sensor.	Switch machine off and on again.
<b>Fault code</b>	<b>Problem</b>	<b>Possible solution. If this does not work, contact Hoeflon.</b>
E117	Incorrect value housing angle sensor.	Switch machine off and on again.
E118	Incorrect value housing dummy sensor.	Check placement of dummy.
E119	Not used.	

E120	No contact with boom rotation sensor.	Switch machine off and on again.
E121	Incorrect value boom rotation sensor.	Switch machine off and on again.
E122	Incorrect value boom rotation sensor.	Switch machine off and on again.
E123	Not used.	
E124	Oil pressure too low Yanmar engine.	Check engine oil level.
E125	Engine temperature too high.	Check coolant level.
E126	Alternator not charging.	Check alternator.
E127	Not used.	
E128	Not used.	
E129	Not used.	
E130	Not used.	
E131	Ballast is crooked.	Slide ballast in and out.
E132	Ballast is crooked.	Slide ballast in and out.
E133	Ballast is crooked.	Slide ballast in and out.
E134	Not used.	
E135	Oil pressure winch sensor incorrect.	Contact Hoeflon or your dealer.
E136	No contact with pressure sensor.	Switch machine off and on again.
E137	Incorrect value pressure sensor.	Switch machine off and on again.
E138	Pressure too high.	Unroll winch cable, reduce lifting weight.
E139	Fault in winch switch.	Winch cable can only be rolled out.
E140	Fault in winch switch.	Winch cable can only be rolled up.
E141	Not used.	
E142	Not used.	
E143	Not used.	
E144	Not used.	
E145	Not used.	
E146	Not used.	
E147	Not used.	
E148	No contact with level sensor.	Switch machine off and on again.
E149	Invalid value level sensor.	Switch machine off and on again.
E150	Not used.	
E151	Not used.	
E142	Maintenance (minor service).	Contact Hoeflon or your dealer.
E153	Maintenance (major service).	Contact Hoeflon or your dealer.
E154	Maintenance.	Contact Hoeflon or your dealer.

## 7.10 Emergency control



**DANGER!**

The emergency control may only be used when the crane no longer functions at all. All the safety measures are bypassed and the user bears full responsibility!



Figure: 91

- Remove the round head bolts from the rear cover, and remove the shroud from the crane (see figure 92).



Figure: 92

- Unscrew the left side of the connector from the pump valve (see figure 93).



Figure: 93

- Attach one connector of the emergency control set here (see figures 91 and 94).



Figure: 94

- The valve block has seven valves with two functions per valve. Before using the emergency control, check which function must be operated.  
The table below shows which two functions per valve can be operated. Functions A to G can be operated without connecting a plug from the emergency control.  
If functions A1 to G1 must be operated, a plug from the emergency control must be connected.

	Function without emergency control plug:		Function with emergency control plug:
A	Slewing	A1	Left-front outrigger
B	Extending/retracting boom	B1	Left-rear outrigger
C	Extension/retraction fly jib	C1	Driving left
D	Winch	D1	Driving right
E	Raising/lowering fly jib	E1	Right-rear outrigger
F	Raising/lowering boom	F1	Right-front outrigger
G	Extending/retracting ballast	G1	Extent/retract tracks

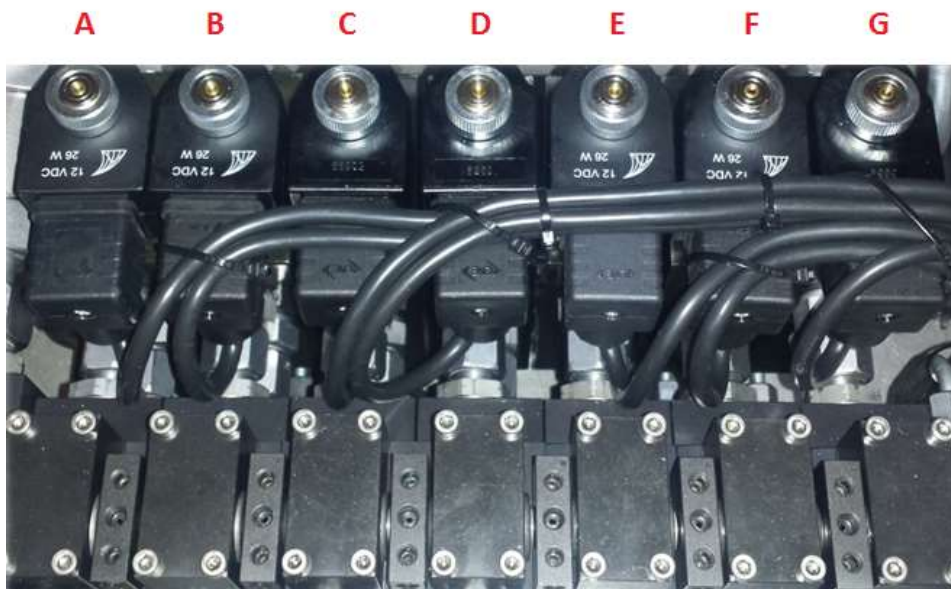

Figure: 95.

- Look up the function to be operated in the table above and choose the correct valve (see figure 95).

- Unscrew the coil on the valve (*see figure 96*) and swap the plug with a plug from the emergency control (*see figure 91*). Once this plug is attached, the coil with plug can be reattached.

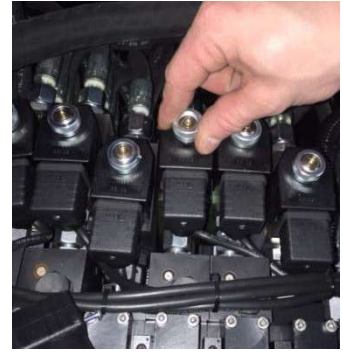

Figure: 96



Figure: 97

- Screw the control lever (*see figure 91*) in the valve this is to be operated (*see figure 98*).



Figure: 98

- Remove the protective cap from the start assistance terminals (*see figure 99*).



Figure: 99

- Place the red clamp on the start assistance terminal with the red protective cap, and place the black clamp on the start assistance terminal with the black protective cap (*see figure 100*).



Figure: 100

- Insert the key (see figure 91) in the key switch (see figure 101) to the right of the electrical cabinet.
- When the engine is cold, the key must first be turned to the left and held for ten seconds to preheat the engine.
- Turn the key to the right and start the machine.

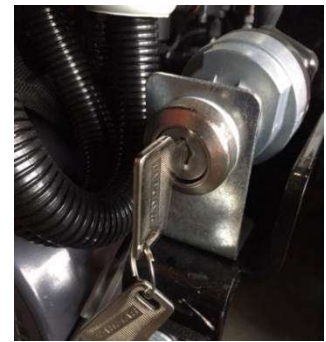

Figure: 101

- The crane functions can now be operated. The table below and figure 102 show which actuating direction is which function.



**DANGER!**

ATTENTION! It is strictly prohibited to extend the boom outreach (by extending the mast)!

	Forwards	Backwards
A	Slew to the right	Slew to the left
A1	Lower left-front outrigger	Raise left-front outrigger
B	Extend boom	Retract boom
B1	Lower left-rear outrigger	Raise left-rear outrigger
C	Extend fly jib	Retract fly jib
C1	Drive forwards to the left	Drive backwards to the left
D	Roll out winch	Roll up winch
D1	Drive forwards to the right	Drive backwards to the right
E	Raise fly jib	Lower fly jib
E1	Lower right-rear outrigger	Raise right-rear outrigger
F	Raise boom	Lower boom
F1	Lower right-front outrigger	Raise right-front outrigger
G	Extend ballast	Retract ballast
G1	Expand tracks	Retract tracks

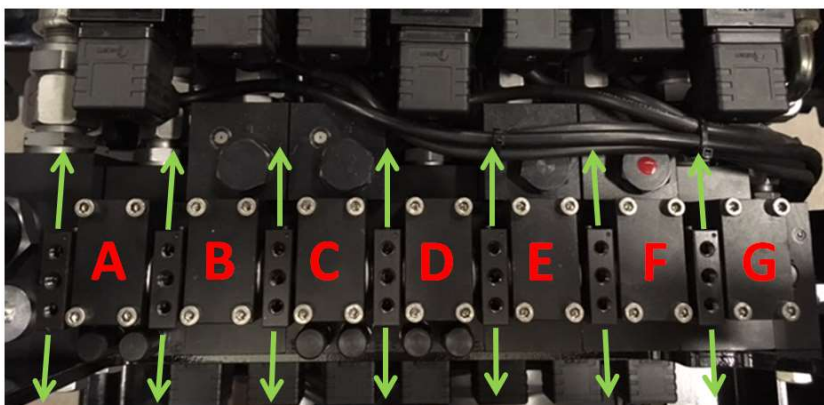

Figure: 102

# 8

## TRANSPORT, STORAGE, DISPOSAL

### 8.1 Transport

#### 8.1.1 General



#### WARNING!

Only use suitable lifting accessories with the correct capacity for the lifting application. The lifting accessories must be accompanied by a certificate, have a periodic inspection, be visually inspected and have been found to be suitable for use.



#### WARNING!

The clearance angle of the loading ramps must not exceed 15 degrees.



#### WARNING!

When transporting the compact crane, make sure the crane is in transport mode and that any load is removed: no load on the hook, outriggers stowed and secured, and boom retracted.

- Make sure the outriggers are fully retracted and locked in position and that the crane is fully collapsed.
- There must not be any load on the compact crane.
- Use loading ramps of sufficient size and capacity. The loading ramps must be long enough so that the angle with the ground is less than 15°.
- Drive the machine forwards onto a means of transport intended for this purpose in the way described in section 6.4; when driving the machine up the ramps the operator must be assisted by a person who provides instructions concerning the driving direction.
- Stop the motor/engine as described in section 6.4.
- Set the switch on the electrical cabinet to position '0'. Remove any loose parts from the machine.
- Secure the machine by attaching four lashing straps to the round holes in the outrigger leg pivots (see figure 103).
- Make sure the outriggers are fully retracted and locked in position and that the crane is fully collapsed.
- There must not be any load on the compact crane.



Figure: 103

- Lift the Compact Crane using 2 lashing straps or chains with a capacity of at least 2500 kg per strap/chain. Attach these to the lifting point on the boom (see figure 104).

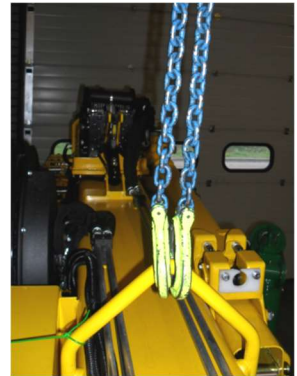

Figure: 104

### 8.1.1 Securing



**WARNING!**

Overloaded eyes can cause damage to the machine. Therefore always heed the following instructions.



**WARNING!**

Folding a lashing strap double also doubles the applied tension.

Point	Load on attachment point
Lashing points on undercarriage	Max. 2500 kg per eye

- Towards the front and sides, lash down at least 0.5x the machine's weight; towards the rear lash down at least 1x the machine's weight.
- It is recommended that the space between the headboard of the transport vehicle and the front of both tracks be filled, in connection with braking forces. Otherwise, use lashing provisions that can hold at least 1.5x the machine's weight at the rear.
- If the lashing eyes on the undercarriage are used to secure the crane, the superstructure must be secured to prevent rotation in both directions. Otherwise the turntable may be damaged by movement that occurs during transport.
- Make sure the tracks of the compact crane are resting directly on the deck of the transport vehicle, because ground protection plates or anything similar in between will reduce the sliding resistance of the crane relative to the transport vehicle.

## 8.2 Storage

Perform the following procedure before storing the compact crane for longer than 3 months:

- Remove any dirt and clean the machine with water and e.g. car wash shampoo. The crawler track undercarriage may be cleaned at high pressure.
- Grease the compact crane in accordance with the lubrication chart in section 7.4.
- Touch up any damage to the paintwork.
- Oil parts that may rust easily, such as exposed sections of hydraulic piston rods.
- Place the compact crane in a dry location, protected from rain, heat and cold.
- Disconnect both battery terminals.
- Ensure that the compact crane cannot be activated by unauthorized persons.
- Cover the compact crane with a tarpaulin; Keep a strip along the floor uncovered to allow ventilation.
- 
- After the compact crane has been in storage for an extended period (longer than 3 months), follow these instructions:
- Remove the tarpaulin.
- Check the battery voltage and charge if necessary.
- Connect the battery cables; pay attention to the polarity.
- Perform the daily inspection.



<b>CAUTION!</b>
-----------------

If the compact crane will be placed in storage for more than six months, contact Hoeflon International B.V. for the procedure to be followed.

## 8.3 Disposal

Dispose of waste in accordance with the applicable local regulations. Incorrect disposal of waste can be harmful to the environment. Environmentally harmful waste includes: engine oil, diesel fuel, hydraulic oil, differential oil, coolant, filters, batteries and greases.

# 9

## ANNEXES

---

### 9.1 Load chart C10

Angle main boom	Load fly-jib [kg]									
	nr.	A	B	C	D	E	F	G	H	I
85	5	748	532	317	803	701	600	858	870	883
	4	584	416	247	627	525	468	670	680	689
	3	498	318	178	478	409	354	539	550	559
	2	374	230	139	350	306	267	415	424	433
	1	274	170	103	250	217	188	315	324	333
75	5	1038	807	575	1079	984	888	1121	1161	1200
	4	859	668	477	894	814	735	928	961	994
	3	748	531	314	803	637	470	858	872	887
	2	584	415	245	627	525	467	670	680	689
	1	498	318	178	478	409	354	539	550	559
65	5	1038	804	570	1079	982	885	1121	1161	1200
	4	859	666	472	894	813	733	928	961	994
	3	767	595	422	798	726	655	829	858	887
	2	634	462	290	664	592	521	714	733	752
	1	501	329	157	531	459	388	582	601	620
50	5	1001	781	562	1071	944	817	1141	1107	1072
	4	828	611	416	859	732	605	928	885	843
	3	728	551	385	766	665	562	848	775	702
	2	634	462	290	664	592	521	714	733	752
	1	501	329	157	531	459	388	582	601	620
25	5	270	264	258	304	298	293	337	332	328
	4	204	198	192	228	222	217	252	246	242
	3	150	144	138	164	158	152	180	174	168
	2	110	104	98	120	114	108	130	124	118
	1	70	64	58	70	64	58	80	74	68
0	5	82	82	82	93	93	93	104	104	104
	4	329	329	329	369	369	369	408	408	408
	3	498	498	498	571	571	571	643	643	643
	2	566	566	566	649	649	649	735	735	735
	1	566	566	566	649	649	649	735	735	735

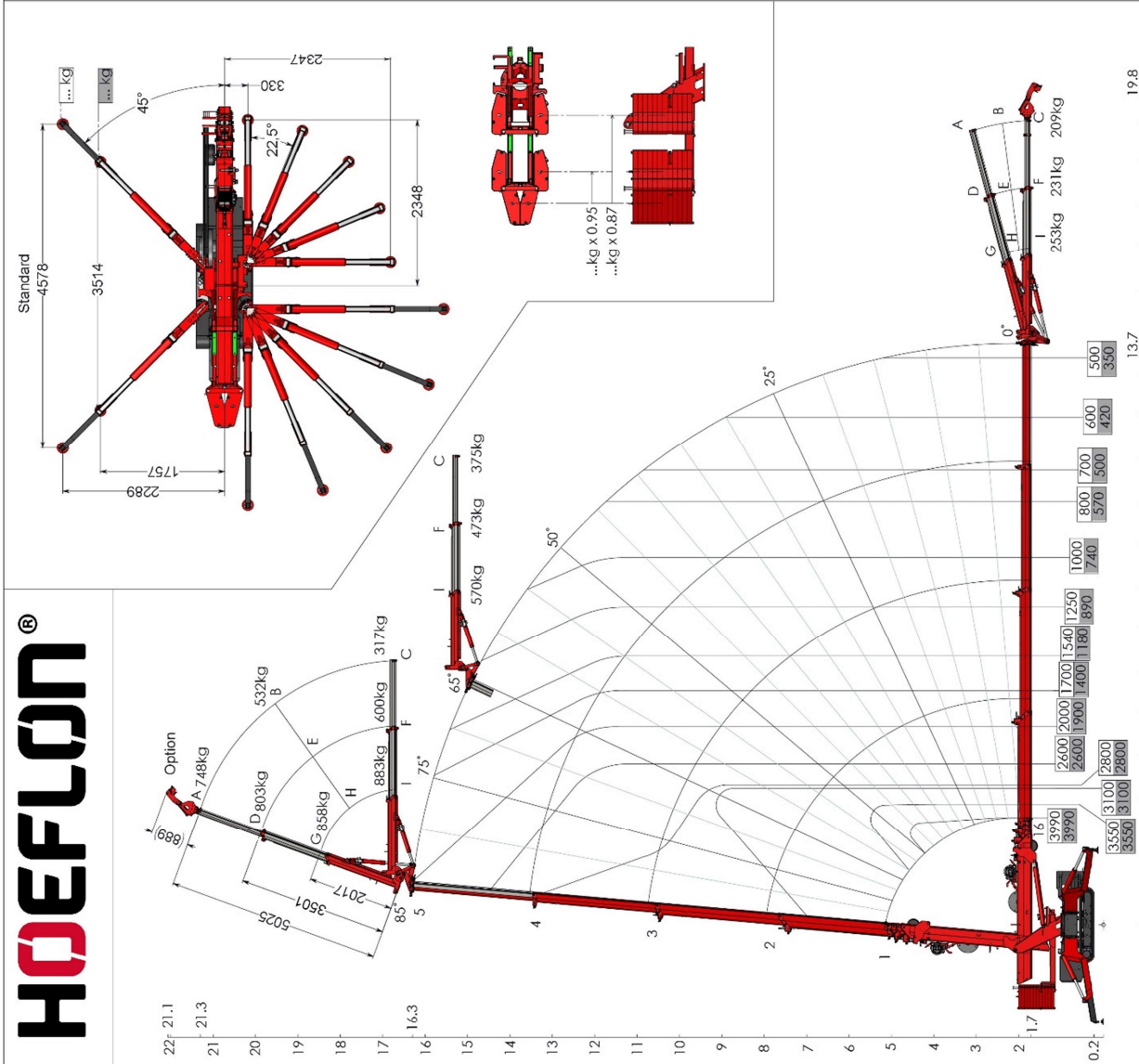

C10 Load diagram v1.4\_26-10-20

## 9.2 Outrigger pressure

### Maximum outrigger pressure C10

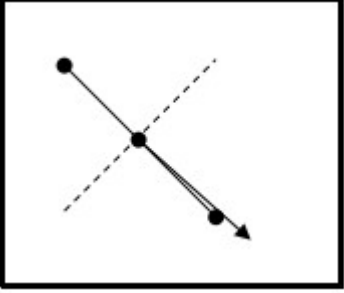
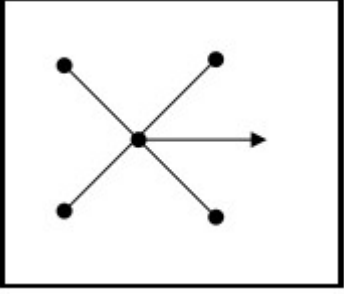
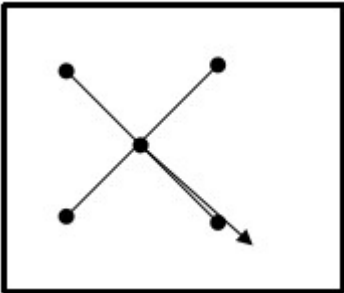
Outrigger radius	2300 mm	2300 mm	Without load
Outrigger angle	4x 45 degrees	4x 45 degrees	4x 45 degrees
Outrigger leg	Retracted	Extended	Retracted/extended
Ballast weight	Extended	Extended	Retracted
Maximum lifting capacity	4000 kg	4000 kg	0 kg
Unladen weight	4400 kg	4400 kg	4400 kg
Maximum outrigger pressure in most unfavourable position	5200 kg	4850 kg	1200 kg
			
Minimum outrigger pressure	3450 kg	3150 kg	1975 kg
			
Maximum outrigger pressure in square configuration	4600 kg	4250 kg	1250
			

## **9.3 Annexes**

- **Crane logbook**